

Cooling Capacity [Btuh]	24,800 *
Condensing Unit SEER:	13.0 **
Condensing Unit CFM:	1,600
Condenser Fan No./Type:	1/CENTRIFUGAL
Diameter x Width [in]:	10x10
Drive:	Adjustable Belt
Motor HP:	0.5
Condenser Coil Face Area:	5.83 [sq ft]
Rows/FPI:	4/16

Compressor No./Type:	1/Scroll
Refrigerant Circuits:	1/Independent
Capacity Steps (%):	100/0
Suction Line OD (in):	3/4
Liquid Line OD (in):	3/8
Refrigerant:	<b>R-410A</b>
Charge:	n/a
<b>Unit shipped with Nitrogen holding charge only</b>	
Operating Weight [lbs.]:	387
Shipping Weight [lbs.]:	407

\* Net Capacity in combination with ESH024 horizontal air handling unit.  
 \*\*Rated in accordance with DOE test procedures and ARI Standard 210-240.

**CONDENSER FAN PERFORMANCE**

OUTDOOR CFM	EXTERNAL STATIC PRESSURE - Inches W.C.							
	0.2		0.4		0.6		0.8	
	RPM	BHP	RPM	BHP	RPM	BHP	RPM	BHP
<b>1600</b>	750	0.29	852	0.35	948	0.42	996	0.46

**ELECTRICAL DATA**

VOLTAGE	COMPRESSOR			CONDENSER FAN		MIN. CCT. AMPACITY	Max Overcurrent Protection
	QTY	RLA	LRA	HP	FLA		
208-230/1/60	1	@ 13.5	58.3	0.50	4.5	21.38	30
208-230/3/60	1	@ 8.6	55.0	0.50	2.2	12.95	20

**KSH024 Condensing Unit Performance**

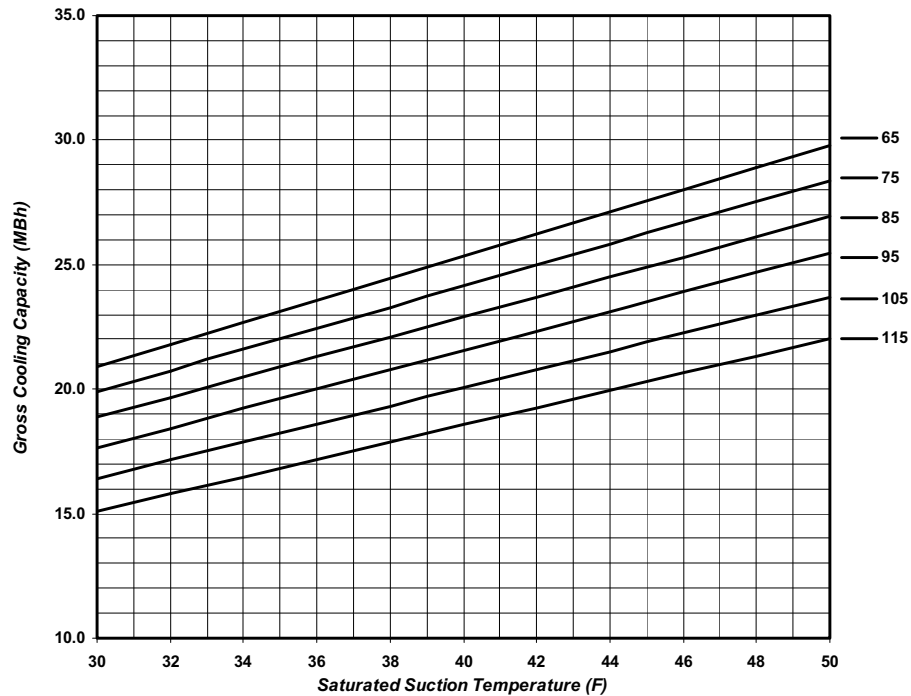

Performance data calculated at 15°F subcooling and 20°F superheat. Figures shown do not include capacity loss due to refrigerant line pressure drop.

Johnson Controls maintains a continuous product improvement policy; therefore specifications are subject to change without notice.

	DESCRIPTION KSH024 PERFORMANCE DATA R-410A KSH SERIES HORIZONTAL INDOOR CONDENSING UNITS	Form 145.28-PA1 (1108)
		DATE: November 2008

**GENERAL**

All models 2-5 tons ship as fully assembled and wired units. Units include "Scroll" type, R-410A, hermetic compressor(s), aluminum fin/copper tube condenser coil, condenser fan and motor, and all necessary controls. Units are shipped with a Nitrogen holding charge only. All models are designed for suspended mounting via integral structural channels.

**CABINET**

All cabinets are completely constructed of heavy gauge galvanized steel. The unit interior is insulated with 1/2" thick, 2-lb density insulation. Service panels are equipped with lifting handles for ease of removal and handling. Duct flanges for condenser discharge and condenser intake are provided with the unit for field installation.

**REFRIGERANT CIRCUITS**

All models utilize "Scroll" type hermetic compressors. Compressors are mounted on rubber isolators to minimize vibration transmission. Internal overload protection is provided. External high pressure and low pressure cut-out switches are included in each compressor control circuit. Crankcase heaters are standard on all models. The 2-5 ton units have a single refrigeration circuit.

**CONDENSER COILS**

The condenser coil is constructed of internally enhanced copper tubes mechanically bonded to rippled aluminum plate fins. Coils are employed in a draw-thru configuration.

**CONDENSER FAN AND MOTOR**

Forward curved, double inlet and double width centrifugal blowers are used for condenser air movement. Blower wheels are fabricated of galvanized steel. Blowers employ solid steel shafts, supported in permanently lubricated ball bearings. All blowers are belt driven. Variable-pitch motor sheaves allow for field adjustment of blower rpm. Motor shall be 1800 RPM, open drip proof design. Three-phase motors are provided with external manual reset overload protection. Single-phase motors feature auto reset internal overloads.

**ELECTRICAL/CONTROLS**

All units are completely factory wired with all necessary controls. A manual reset circuit is also provided on each compressor control circuit in the event of high/low pressure cut-out. A 24 volt control circuit, with oversize transformer, is provided for field connection.

**FACTORY INSTALLED OPTIONS**

**Corrosion Resistant Coatings.** Condenser coil shall receive a 1-mil thickness of a cathodic epoxy type electro-deposition coating, applied in a multiple dip and bake process.

**Anti-Short Cycle Timer.** Time delay relay will be provided for each compressor circuit. Compressor will be locked out for 5 minutes when thermostat contact opens, or there is a momentary power outage.

**FIELD INSTALLED OPTIONS**

**Low Ambient Control.** Head pressure control damper kit will allow unit operation down to 0 F ambient. Damper assembly mounts on condenser air intake. The kit includes damper actuator and low pressure switch bypass timer(s).

*Johnson Controls maintains a continuous product improvement policy; therefore specifications are subject to change without notice.*

	DESCRIPTION MECHANICAL SPECIFICATION R-410A KSH SERIES HORIZONTAL INDOOR CONDENSING UNITS	Form 145.28-PA1 (1108)
		DATE: November 2008

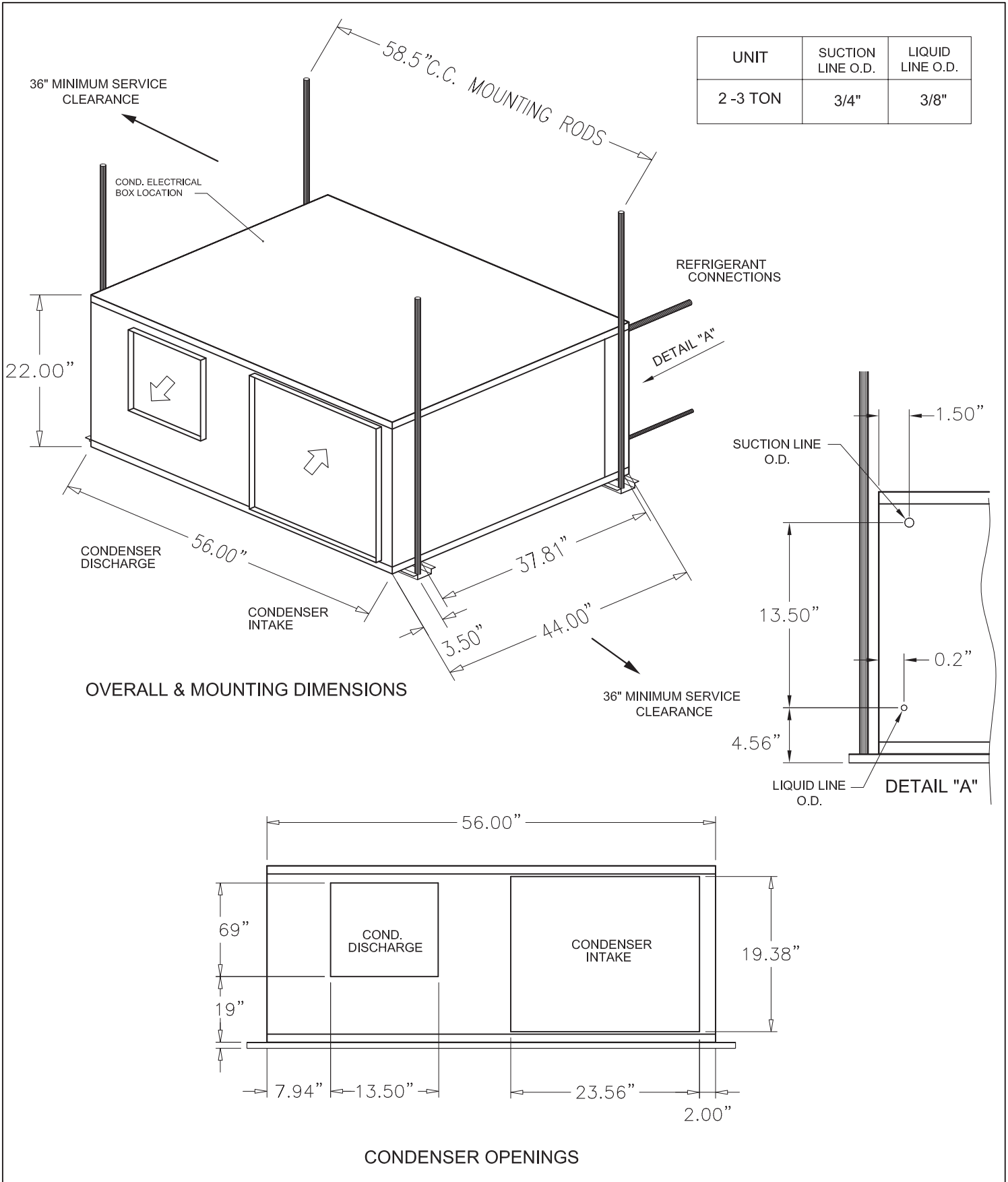

UNIT	SUCTION LINE O.D.	LIQUID LINE O.D.
2-3 TON	3/4"	3/8"



DESCRIPTION:

**KSH024 & KSH036**

**HORIZONTAL AIR-COOLED CONDENSING UNIT**

**DIMENSIONAL DATA**

Form 145.28-PA1 (1108)

DATE:

**November 2008**

Cooling Capacity [Btuh]	36,100 *
Condensing Unit SEER:	13.0 **
Condensing Unit CFM:	1,950
Condenser Fan No./Type:	1/CENTRIFUGAL
Diameter x Width [in]:	10x10
Drive:	Adjustable Belt
Motor HP:	0.75
Condenser Coil Face Area:	5.83 [sq ft]
Rows/FPI:	4/16

Compressor No./Type:	1/Scroll
Refrigerant Circuits:	1/Independent
Capacity Steps (%):	100/0
Suction Line OD (in):	3/4
Liquid Line OD (in):	3/8
Refrigerant:	<b>R-410A</b>
Charge:	n/a
<b>Unit shipped with Nitrogen holding charge only</b>	
Operating Weight [lbs.]:	408
Shipping Weight [lbs.]:	438

\* Net Capacity in combination with ESH036 horizontal air handling unit.  
 \*\*Rated in accordance with DOE test procedures and ARI Standard 210-240.

**CONDENSER FAN PERFORMANCE**

OUTDOOR CFM	EXTERNAL STATIC PRESSURE - Inches W.C.									
	0.2		0.4		0.6		0.8		1.0	
	RPM	BHP	RPM	BHP	RPM	BHP	RPM	BHP	RPM	BHP
<b>1950</b>	864	0.47	949	0.55	1032	0.63	1112	0.72	-	-

**ELECTRICAL DATA**

VOLTAGE	COMPRESSOR			CONDENSER FAN		MIN. CCT. AMPACITY	Max Overcurrent Protection
	QTY	RLA	LRA	HP	FLA		
208-230/1/60	1 @	14.1	77.0	0.75	5.5	23.13	35
208-230/3/60	1 @	9.0	71.0	0.75	2.6	13.85	20
460/3/60	1 @	5.6	38.0	0.75	1.3	8.30	15
575/3/60	1 @	3.8	36.5	0.75	1.0	5.75	15

**KSH036 Condensing Unit Performance**

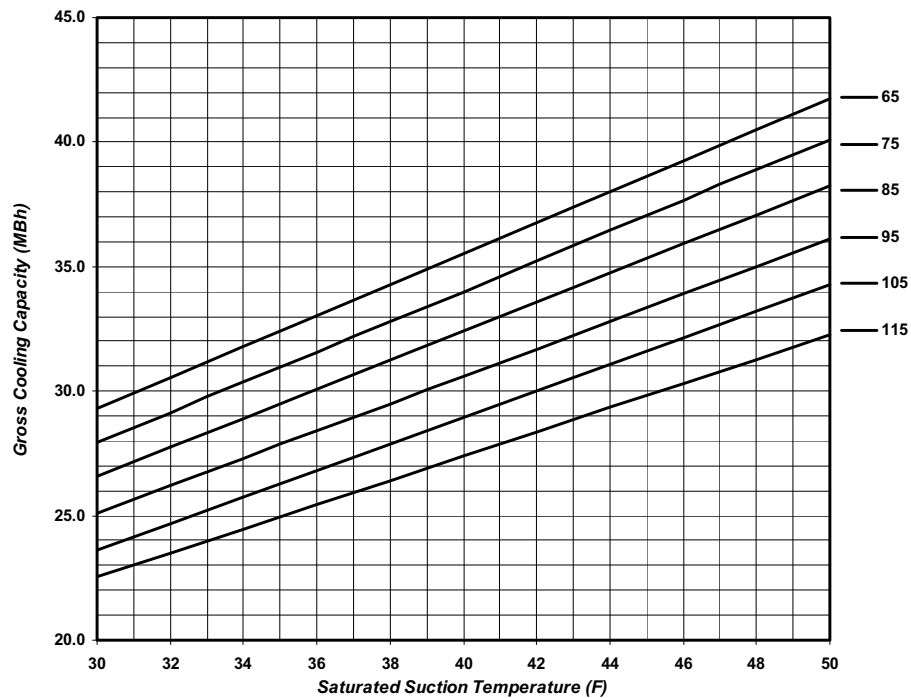

Performance data calculated at 15°F subcooling and 20°F superheat. Figures shown do not include capacity loss due to refrigerant line pressure drop.

Johnson Controls maintains a continuous product improvement policy; therefore specifications are subject to change without notice.



DESCRIPTION  
 KSH036 PERFORMANCE DATA  
 R-410A KSH SERIES  
 HORIZONTAL INDOOR CONDENSING UNITS

Form 145.28-PA2 (1108)  
 DATE:  
 November 2008

**GENERAL**

All models 2-5 tons ship as fully assembled and wired units. Units include "Scroll" type, R-410A, hermetic compressor(s), aluminum fin/copper tube condenser coil, condenser fan and motor, and all necessary controls. Units are shipped with a Nitrogen holding charge only. All models are designed for suspended mounting via integral structural channels.

**CABINET**

All cabinets are completely constructed of heavy gauge galvanized steel. The unit interior is insulated with 1/2" thick, 2-lb density insulation. Service panels are equipped with lifting handles for ease of removal and handling. Duct flanges for condenser discharge and condenser intake are provided with the unit for field installation.

**REFRIGERANT CIRCUITS**

All models utilize "Scroll" type hermetic compressors. Compressors are mounted on rubber isolators to minimize vibration transmission. Internal overload protection is provided. External high pressure and low pressure cut-out switches are included in each compressor control circuit. Crankcase heaters are standard on all models. The 2-5 ton units have a single refrigeration circuit.

**CONDENSER COILS**

The condenser coil is constructed of internally enhanced copper tubes mechanically bonded to rippled aluminum plate fins. Coils are employed in a draw-thru configuration.

**CONDENSER FAN AND MOTOR**

Forward curved, double inlet and double width centrifugal blowers are used for condenser air movement. Blower wheels are fabricated of galvanized steel. Blowers employ solid steel shafts, supported in permanently lubricated ball bearings. All blowers are belt driven. Variable-pitch motor sheaves allow for field adjustment of blower rpm. Motor shall be 1800 RPM, open drip proof design. Three-phase motors are provided with external manual reset overload protection. Single-phase motors feature auto reset internal overloads.

**ELECTRICAL/CONTROLS**

All units are completely factory wired with all necessary controls. A manual reset circuit is also provided on each compressor control circuit in the event of high/low pressure cut-out. A 24 volt control circuit, with oversize transformer, is provided for field connection.

**FACTORY INSTALLED OPTIONS**

**Corrosion Resistant Coatings.** Condenser coil shall receive a 1-mil thickness of a cathodic epoxy type electro-deposition coating, applied in a multiple dip and bake process.

**Anti-Short Cycle Timer.** Time delay relay will be provided for each compressor circuit. Compressor will be locked out for 5 minutes when thermostat contact opens, or there is a momentary power outage.

**FIELD INSTALLED OPTIONS**

**Low Ambient Control.** Head pressure control damper kit will allow unit operation down to 0 F ambient. Damper assembly mounts on condenser air intake. The kit includes damper actuator and low pressure switch bypass timer(s).

*Johnson Controls maintains a continuous product improvement policy; therefore specifications are subject to change without notice.*

	DESCRIPTION MECHANICAL SPECIFICATION R-410A KSH SERIES HORIZONTAL INDOOR CONDENSING UNITS	Form 145.28-PA2 (1108)
		DATE: November 2008

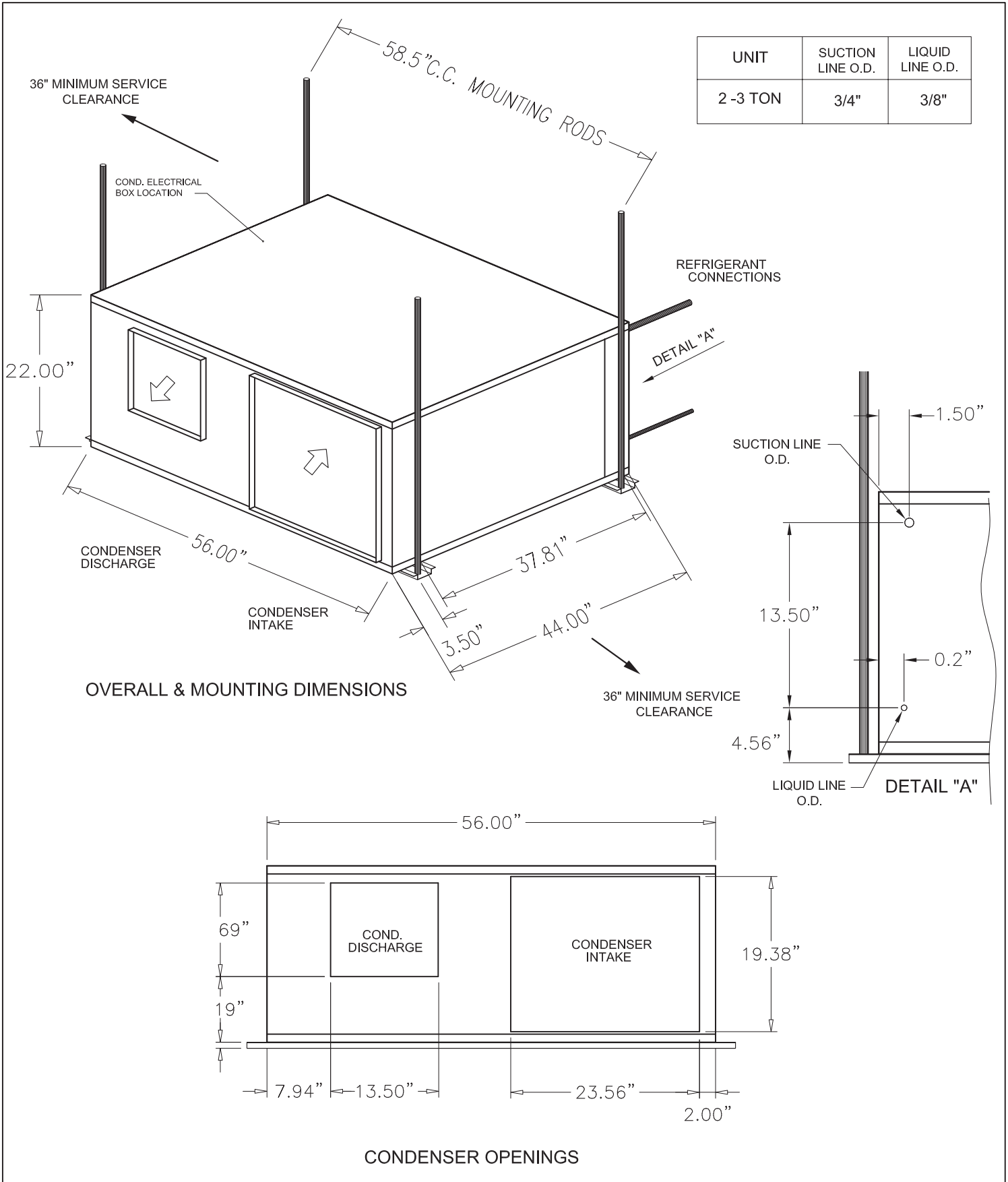

DESCRIPTION:

KSH024 & KSH036  
 HORIZONTAL AIR-COOLED CONDENSING UNIT  
 DIMENSIONAL DATA

Form 145.28-PA2 (1108)

DATE:  
 November 2008

Cooling Capacity [Btuh]	48,700 *
Condensing Unit SEER:	13.0 **
Condensing Unit CFM:	2,500
Condenser Fan No./Type:	1/CENTRIFUGAL
Diameter x Width [in]:	12x11
Drive:	Adjustable Belt
Motor HP:	1.0
Condenser Coil Face Area:	7.19 [sq ft]
Rows/FPI:	4/16

Compressor No./Type:	1/Scroll
Refrigerant Circuits:	1/Independent
Capacity Steps (%):	100/0
Suction Line OD (in):	7/8
Liquid Line OD (in):	1/2
Refrigerant:	<b>R-410A</b>
Charge:	n/a
<b>Unit shipped with Nitrogen holding charge only</b>	
Operating Weight [lbs.]:	494
Shipping Weight [lbs.]:	524

\* Net Capacity in combination with ESH048 horizontal air handling unit.  
 \*\*Rated in accordance with DOE test procedures and ARI Standard 210-240.

**CONDENSER FAN PERFORMANCE**

OUTDOOR CFM	EXTERNAL STATIC PRESSURE - Inches W.C.									
	0.2		0.4		0.6		0.8		1.0	
	RPM	BHP	RPM	BHP	RPM	BHP	RPM	BHP	RPM	BHP
<b>2500</b>	645	0.53	749	0.63	812	0.74	872	0.86	945	0.98

**ELECTRICAL DATA**

VOLTAGE	COMPRESSOR			CONDENSER FAN		MIN. CCT. AMPACITY	Max Overcurrent Protection
	QTY	RLA	LRA	HP	FLA		
208-230/1/60	1	@ 19.9	109.0	1.00	6.3	31.18	50
208-230/3/60	1	@ 13.1	83.1	1.00	3.3	19.68	30
460/3/60	1	@ 6.1	41.0	1.00	1.5	9.13	15
575/3/60	1	@ 5.0	34.0	1.00	1.1	7.35	15

**KSH048 Condensing Unit Performance**

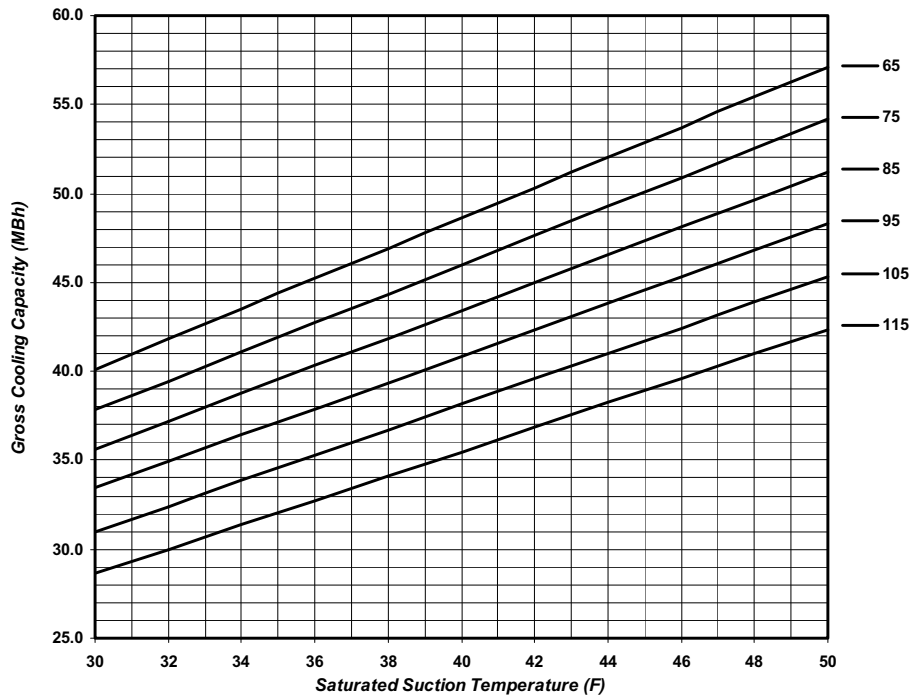

Performance data calculated at 15°F subcooling and 20°F superheat. Figures shown do not include capacity loss due to refrigerant line pressure drop.

Johnson Controls maintains a continuous product improvement policy; therefore specifications are subject to change without notice.



DESCRIPTION

KSH048 PERFORMANCE DATA  
 R-410A KSH SERIES  
 HORIZONTAL INDOOR CONDENSING UNITS

Form 145.28-PA3 (1108)

DATE:

November 2008

**GENERAL**

All models 2-5 tons ship as fully assembled and wired units. Units include "Scroll" type, R-410A, hermetic compressor(s), aluminum fin/copper tube condenser coil, condenser fan and motor, and all necessary controls. Units are shipped with a Nitrogen holding charge only. All models are designed for suspended mounting via integral structural channels.

**CABINET**

All cabinets are completely constructed of heavy gauge galvanized steel. The unit interior is insulated with 1/2" thick, 2-lb density insulation. Service panels are equipped with lifting handles for ease of removal and handling. Duct flanges for condenser discharge and condenser intake are provided with the unit for field installation.

**REFRIGERANT CIRCUITS**

All models utilize "Scroll" type hermetic compressors. Compressors are mounted on rubber isolators to minimize vibration transmission. Internal overload protection is provided. External high pressure and low pressure cut-out switches are included in each compressor control circuit. Crankcase heaters are standard on all models. The 2-5 ton units have a single refrigeration circuit.

**CONDENSER COILS**

The condenser coil is constructed of internally enhanced copper tubes mechanically bonded to rippled aluminum plate fins. Coils are employed in a draw-thru configuration.

**CONDENSER FAN AND MOTOR**

Forward curved, double inlet and double width centrifugal blowers are used for condenser air movement. Blower wheels are fabricated of galvanized steel. Blowers employ solid steel shafts, supported in permanently lubricated ball bearings. All blowers are belt driven. Variable-pitch motor sheaves allow for field adjustment of blower rpm. Motor shall be 1800 RPM, open drip proof design. Three-phase motors are provided with external manual reset overload protection. Single-phase motors feature auto reset internal overloads.

**ELECTRICAL/CONTROLS**

All units are completely factory wired with all necessary controls. A manual reset circuit is also provided on each compressor control circuit in the event of high/low pressure cut-out. A 24 volt control circuit, with oversize transformer, is provided for field connection.

**FACTORY INSTALLED OPTIONS**

**Corrosion Resistant Coatings.** Condenser coil shall receive a 1-mil thickness of a cathodic epoxy type electro-deposition coating, applied in a multiple dip and bake process.

**Anti-Short Cycle Timer.** Time delay relay will be provided for each compressor circuit. Compressor will be locked out for 5 minutes when thermostat contact opens, or there is a momentary power outage.

**FIELD INSTALLED OPTIONS**

**Low Ambient Control.** Head pressure control damper kit will allow unit operation down to 0 F ambient. Damper assembly mounts on condenser air intake. The kit includes damper actuator and low pressure switch bypass timer(s).

Johnson Controls maintains a continuous product improvement policy; therefore specifications are subject to change without notice.

	<b>DESCRIPTION</b> MECHANICAL SPECIFICATION R-410A KSH SERIES HORIZONTAL INDOOR CONDENSING UNITS	Form 145.28-PA3 (1108)
		DATE: November 2008

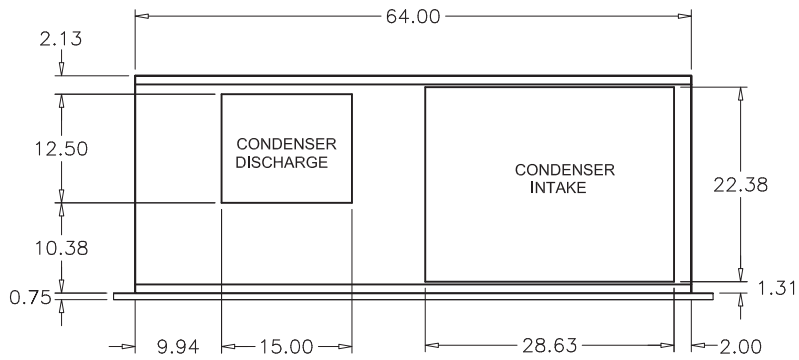
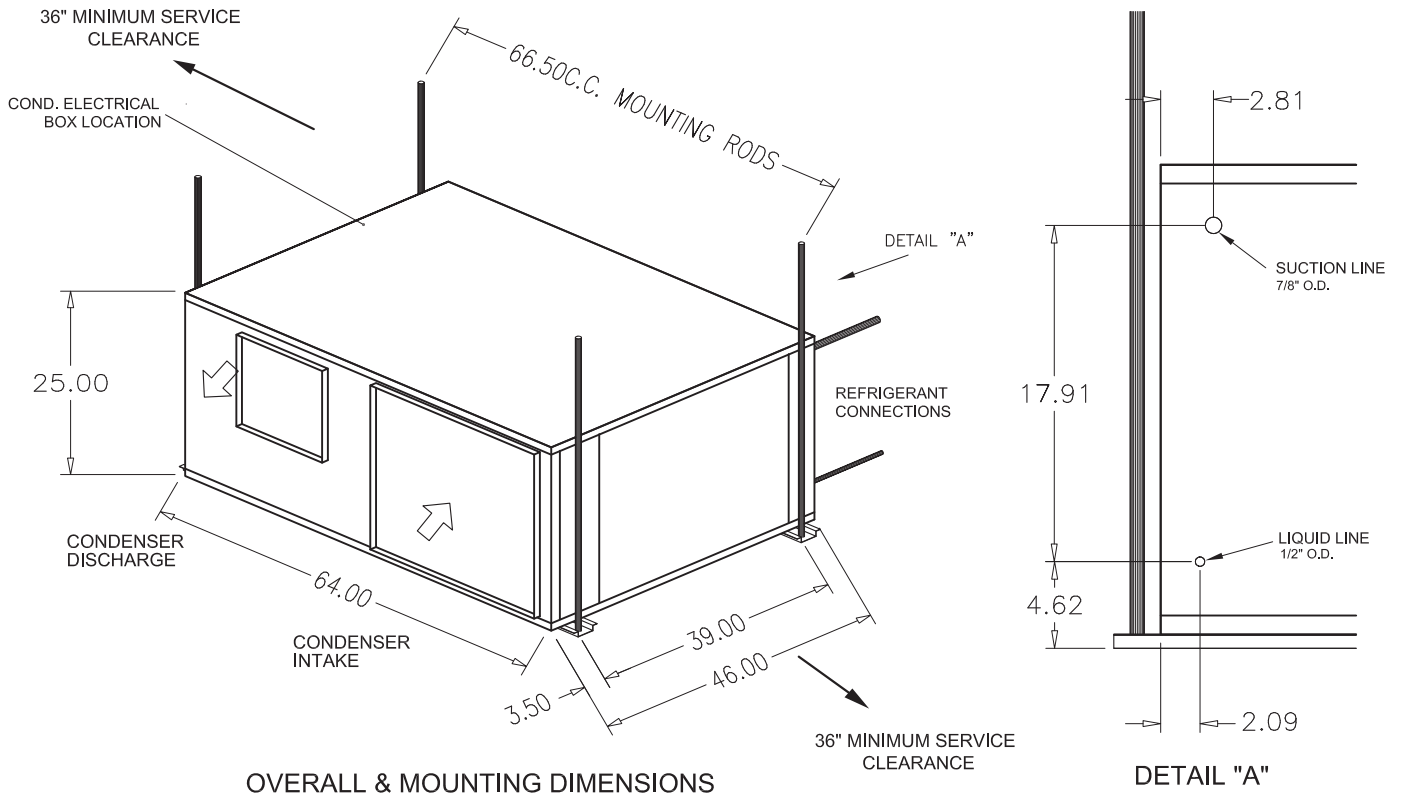

DESCRIPTION:

KSH048 & KSH060  
 HORIZONTAL AIR-COOLED CONDENSING UNIT  
 DIMENSIONAL DATA

Form 145.28-PA3 (1108)

DATE:

November 2008

Cooling Capacity [Btuh]	61,800 *
Condensing Unit SEER:	13.0 **
Condensing Unit CFM:	2,900
Condenser Fan No./Type:	1/CENTRIFUGAL
Diameter x Width [in]:	12x11
Drive:	Adjustable Belt
Motor HP:	1.5
Condenser Coil Face Area:	7.19 [sq ft]
Rows/FPI:	4/16

Compressor No./Type:	1/Scroll
Refrigerant Circuits:	1/Independent
Capacity Steps (%):	100/0
Suction Line OD (in):	7/8
Liquid Line OD (in):	1/2
Refrigerant:	<b>R-410A</b>
Charge:	n/a
<b>Unit shipped with Nitrogen holding charge only</b>	
Operating Weight [lbs.]:	496
Shipping Weight [lbs.]:	526

\* Net Capacity in combination with ESH060 horizontal air handling unit.  
 \*\*Rated in accordance with DOE test procedures and ARI Standard 210-240.

**CONDENSER FAN PERFORMANCE**

OUTDOOR CFM	EXTERNAL STATIC PRESSURE - Inches W.C.													
	0.2		0.4		0.6		0.8		1.0		1.2		1.4	
	RPM	BHP	RPM	BHP	RPM	BHP	RPM	BHP	RPM	BHP	RPM	BHP	RPM	BHP
<b>2900</b>	723	0.79	800	0.84	871	1.07	935	1.20	996	1.55	1057	1.42	-	-

**ELECTRICAL DATA**

VOLTAGE	COMPRESSOR			CONDENSER FAN		MIN. CCT. AMPACITY	Max Overcurrent Protection
	QTY	RLA	LRA	HP	FLA		
208-230/3/60	1	@ 16.0	110.0	1.50	4.6	24.60	40
460/3/60	1	@ 7.8	52.0	1.50	2.1	11.85	15
575/3/60	1	@ 5.7	38.9	1.50	1.7	8.83	15

**KSH060 Condensing Unit Performance**

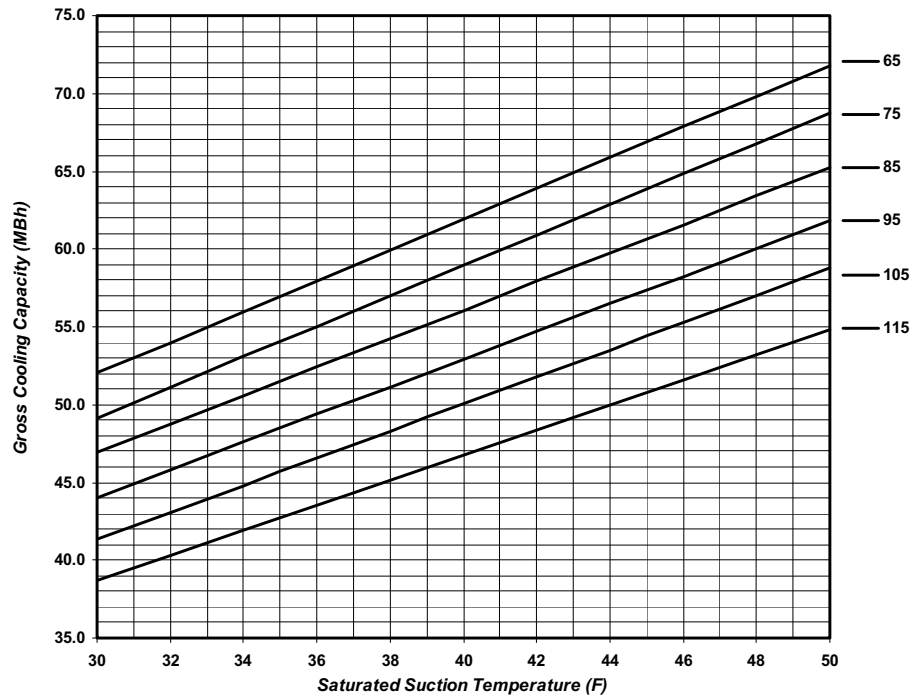

Performance data calculated at 15°F subcooling and 20°F superheat. Figures shown do not include capacity loss due to refrigerant line pressure drop.

Johnson Controls maintains a continuous product improvement policy; therefore specifications are subject to change without notice.

	DESCRIPTION	Form 145.28-PA4 (1108)
	KSH060 PERFORMANCE DATA R-410A KSH SERIES HORIZONTAL INDOOR CONDENSING UNITS	DATE: November 2008

**GENERAL**

All models 2-5 tons ship as fully assembled and wired units. Units include "Scroll" type, R-410A, hermetic compressor(s), aluminum fin/copper tube condenser coil, condenser fan and motor, and all necessary controls. Units are shipped with a Nitrogen holding charge only. All models are designed for suspended mounting via integral structural channels.

**CABINET**

All cabinets are completely constructed of heavy gauge galvanized steel. The unit interior is insulated with 1/2" thick, 2-lb density insulation. Service panels are equipped with lifting handles for ease of removal and handling. Duct flanges for condenser discharge and condenser intake are provided with the unit for field installation.

**REFRIGERANT CIRCUITS**

All models utilize "Scroll" type hermetic compressors. Compressors are mounted on rubber isolators to minimize vibration transmission. Internal overload protection is provided. External high pressure and low pressure cut-out switches are included in each compressor control circuit. Crankcase heaters are standard on all models. The 2-5 ton units have a single refrigeration circuit.

**CONDENSER COILS**

The condenser coil is constructed of internally enhanced copper tubes mechanically bonded to rippled aluminum plate fins. Coils are employed in a draw-thru configuration.

**CONDENSER FAN AND MOTOR**

Forward curved, double inlet and double width centrifugal blowers are used for condenser air movement. Blower wheels are fabricated of galvanized steel. Blowers employ solid steel shafts, supported in permanently lubricated ball bearings. All blowers are belt driven. Variable-pitch motor sheaves allow for field adjustment of blower rpm. Motor shall be 1800 RPM, open drip proof design. Three-phase motors are provided with external manual reset overload protection. Single-phase motors feature auto reset internal overloads.

**ELECTRICAL/CONTROLS**

All units are completely factory wired with all necessary controls. A manual reset circuit is also provided on each compressor control circuit in the event of high/low pressure cut-out. A 24 volt control circuit, with oversize transformer, is provided for field connection.

**FACTORY INSTALLED OPTIONS**

**Corrosion Resistant Coatings.** Condenser coil shall receive a 1-mil thickness of a cathodic epoxy type electro-deposition coating, applied in a multiple dip and bake process.

**Anti-Short Cycle Timer.** Time delay relay will be provided for each compressor circuit. Compressor will be locked out for 5 minutes when thermostat contact opens, or there is a momentary power outage.

**FIELD INSTALLED OPTIONS**

**Low Ambient Control.** Head pressure control damper kit will allow unit operation down to 0 F ambient. Damper assembly mounts on condenser air intake. The kit includes damper actuator and low pressure switch bypass timer(s).

*Johnson Controls maintains a continuous product improvement policy; therefore specifications are subject to change without notice.*

	DESCRIPTION MECHANICAL SPECIFICATION R-410A KSH SERIES HORIZONTAL INDOOR CONDENSING UNITS	Form 145.28-PA4 (1108)
		DATE: November 2008

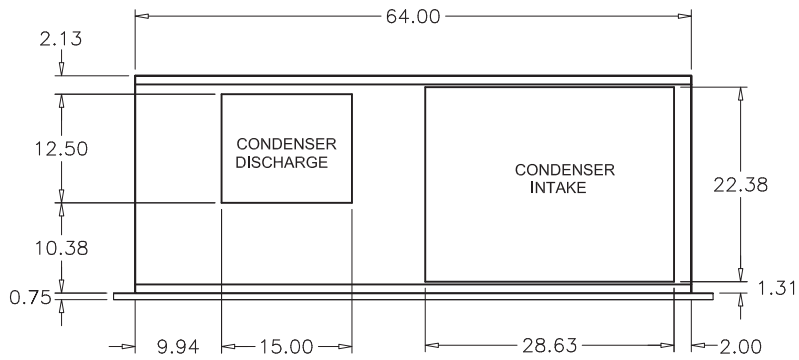
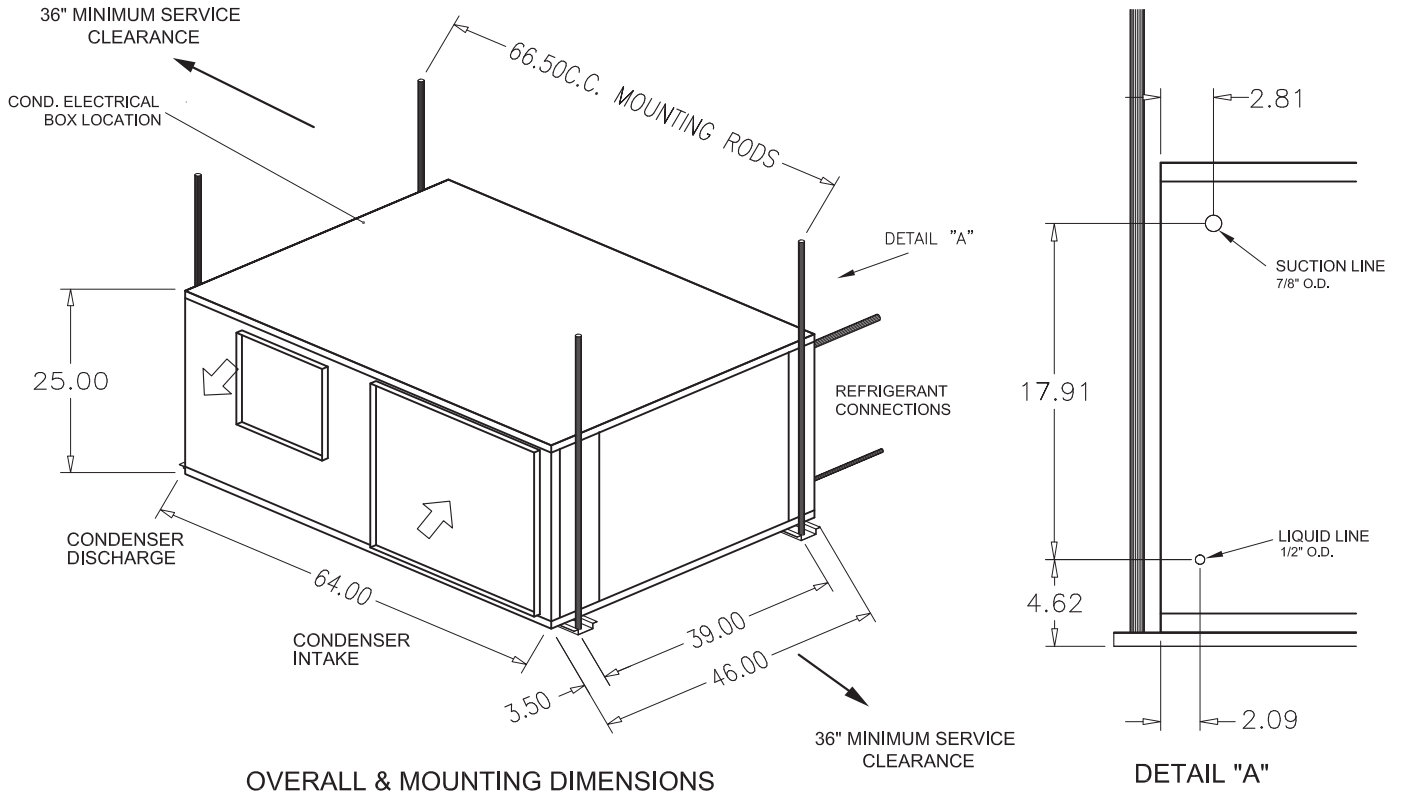

DESCRIPTION:

KSH048 & KSH060  
 HORIZONTAL AIR-COOLED CONDENSING UNIT  
 DIMENSIONAL DATA

Form 145.28-PA4 (1108)

DATE:

November 2008