

# Model: PURY-P72THMU-A – DIMENSIONS

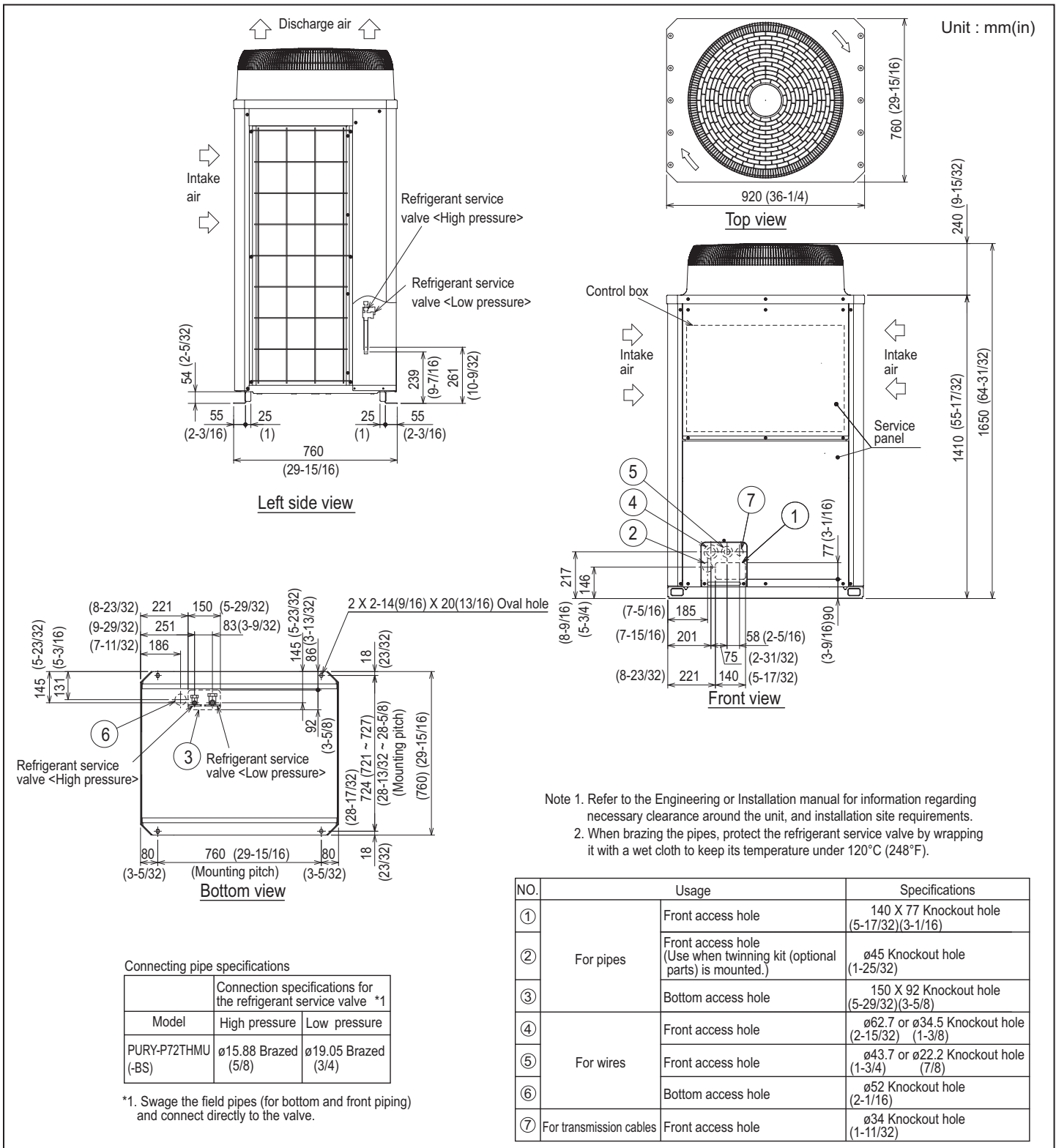

Mitsubishi Electric Air Conditioning & Refrigeration Systems Works acquired ISO 9001 certification under Series 9000 of the International Standard Organization (ISO) based on a review of quality warranties for the production of refrigeration and air conditioning equipment.

ISO Authorization System  
 The ISO 9000 series is a plant authorization system relating to quality warranties as stipulated by the ISO. ISO 9001 certifies quality warranties based on the "design, development, production, installation and auxiliary services" for products built at an authorized plant.



## HVAC Advanced Products Division

Mitsubishi Electric & Electronics USA, Inc.  
 3400 Lawrenceville Suwanee Rd.  
 Suwanee, GA 30024

Tele: 678-376-2900 • Fax: 800-889-9904

Toll Free: 800-433-4822 (#4)

www.mehvac.com

Specifications are subject to change without notice.



Mitsubishi Electric Air Conditioning & Refrigeration Systems Works acquired environmental management system standard ISO 14001 certification.

The ISO 14000 series is a set of standards applying to environmental protection set by the International Standard Organization (ISO).