

Model: PUHY-P120THMU-A – DIMENSIONS

Unit : mm(in)

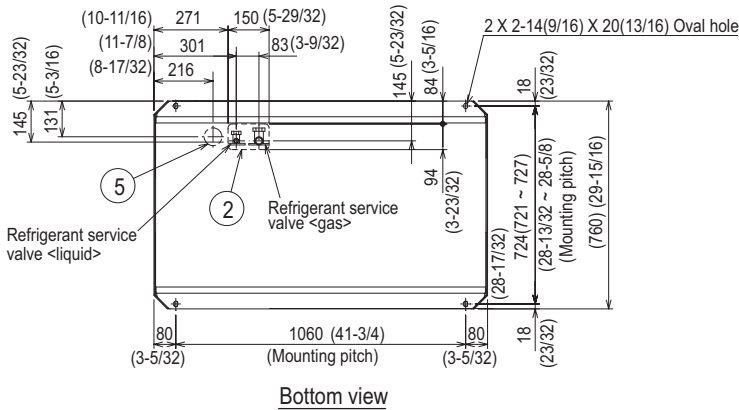
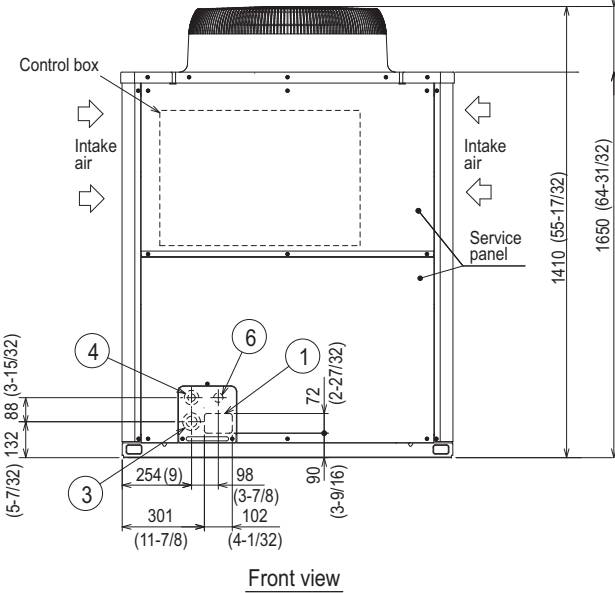
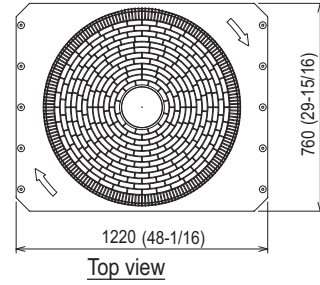
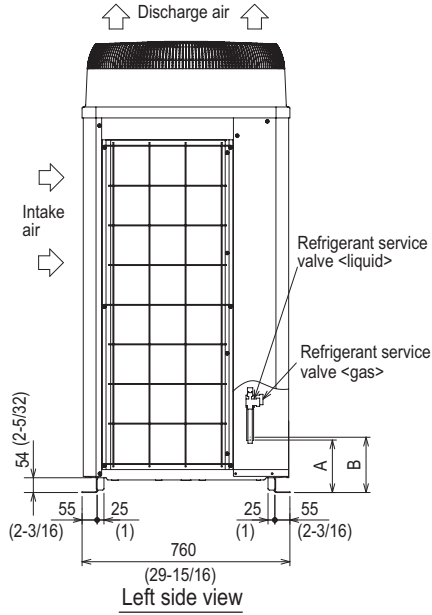

Accessories

- Connecting pipe
 - Gas
 - Elbow (IDø25.4 [1] X ODø25.4 [1]) 1 pc.
 - Pipe (IDø25.4 [1] X ODø22.2 [7/8]) 1 pc.
 - Liquid
 - Pipe (IDø15.88 [5/8] X ODø9.52 [3/8]) 1 pc.
 - Pipe (IDø15.88 [5/8] X ODø12.7 [1/2]) 1 pc.

- Note 1. Refer to the Engineering or Installation manual for information regarding necessary clearance around the unit, and installation site requirements.
 Note 2. When brazing the pipes, protect the refrigerant service valve by wrapping it with a wet cloth to keep its temperature under 120°C (248°F).

Connecting pipe specifications

Model	Position dimensions for the refrigerant service valve		Connection specifications for the refrigerant service valve *1	
	Liquid A	Gas B	Liquid	Gas
PUHY-P120THMU (-BS)	158 (6-1/4)	172 (6-25/32)	ø9.52 Brazed (3/8) ø12.7 Brazed (1/2) *2 *3	ø22.2 Brazed (7/8)

- *1 Use the connecting pipes (for bottom and front pipes) that are supplied.
 *2 Indicates dimensions and connection specifications if the unit is used in combination with other outdoor units.
 *3 Total length ≥ 40m (131')

NO.	Usage	Specifications
①	For pipes	Front access hole 102 X 72 Knockout hole (4-1/32) (2-27/32)
②		Bottom access hole 150 X 94 Knockout hole (5-29/32)(3-23/32)
③	For wires	Front access hole ø62.7 or ø34.5 Knockout hole (2-15/32) (1-3/8)
④		Front access hole ø43.7 or ø22.2 Knockout hole (1-3/4) (7/8)
⑤	For transmission cables	Bottom access hole ø65 Knockout hole (2-9/16)
⑥		Front access hole ø34 Knockout hole (1-11/32)



Certificate Number FM33568

Mitsubishi Electric Air Conditioning & Refrigeration Systems Works acquired ISO 9001 certification under Series 9000 of the International Standard Organization (ISO) based on a review of quality warranties for the production of refrigeration and air conditioning equipment.

ISO Authorization System
 The ISO 9000 series is a plant authorization system relating to quality warranties as stipulated by the ISO. ISO 9001 certifies quality warranties based on the "design, development, production, installation and auxiliary services" for products built at an authorized plant.



HVAC Advanced Products Division

Mitsubishi Electric & Electronics USA, Inc.
 3400 Lawrenceville Suwanee Rd.
 Suwanee, GA 30024
 Tele: 678-376-2900 • Fax: 800-889-9904
 Toll Free: 800-433-4822 (#4)
 www.mehvac.com

Specifications are subject to change without notice.



Certificate Number EC97J1227

Mitsubishi Electric Air Conditioning & Refrigeration Systems Works acquired environmental management system standard ISO 14001 certification.

The ISO 14000 series is a set of standards applying to environmental protection set by the International Standard Organization (ISO).