

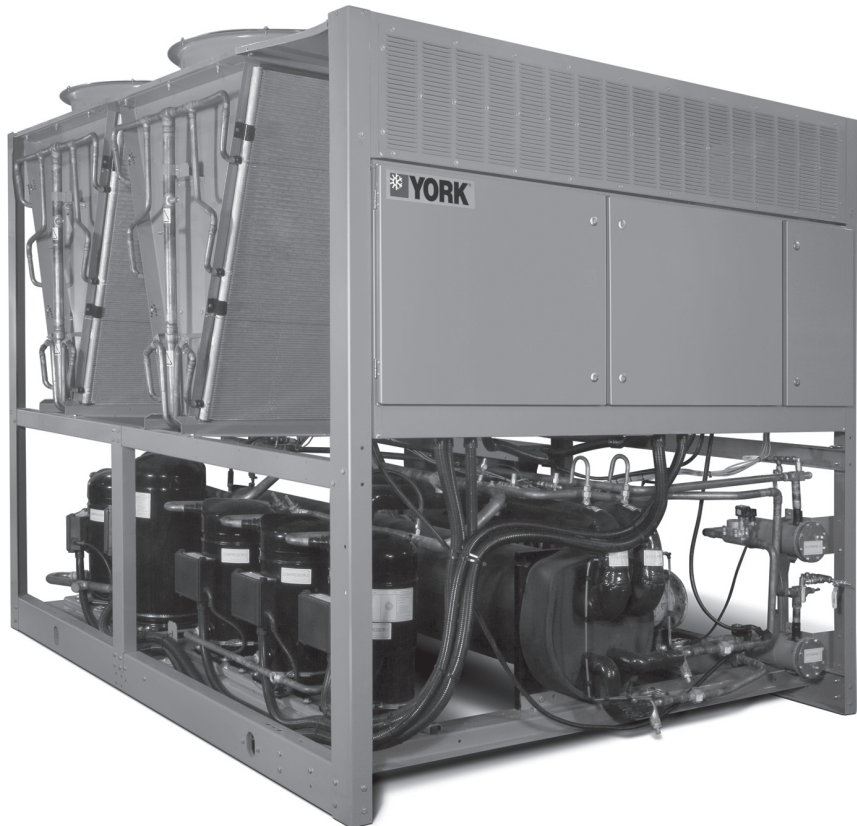

BY JOHNSON CONTROLS



***Model YLAA Air-Cooled Scroll Chillers
Style A***



70 – 175 TON
246 – 527 kW
60 Hz
R-410A

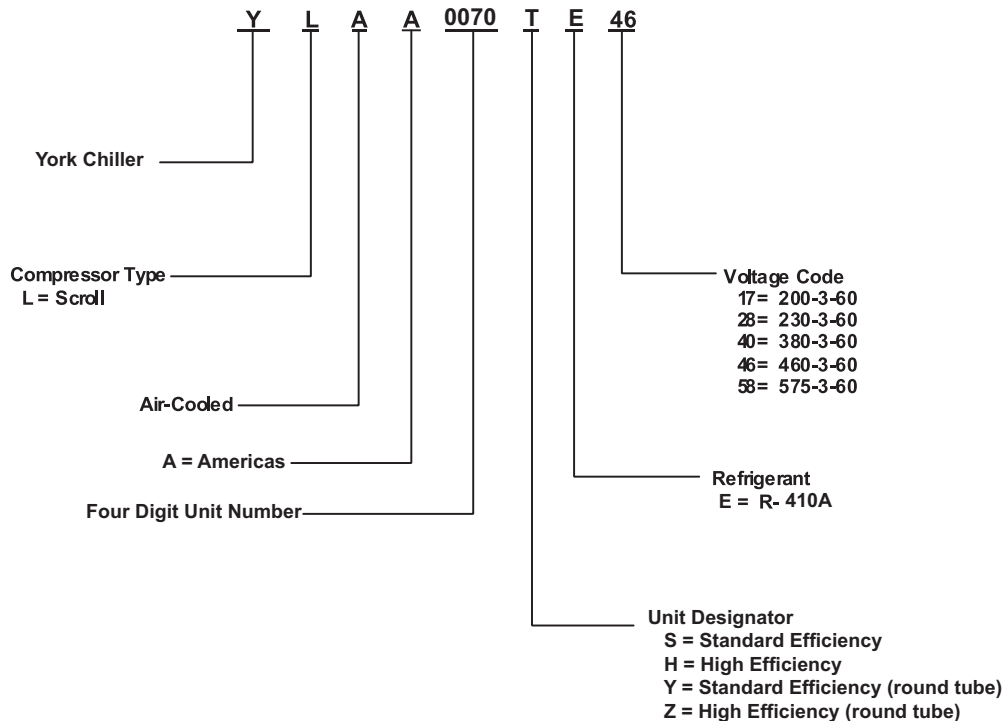

Table of contents

Form 150.62-EG3 (409).....	1
Introduction.....	3
Specifications	4
Microcomputer Control Center	5
Accessories and Options	7
Design Parameters.....	10
Water Pressure Drop.....	11
Selection Criteria and Procedures.....	12
Pump Selection Criteria.....	14
Pump Pressure Drop Curves.....	16
Single Pump Curves.....	18
Dual Pump Curves.....	19
Ratings - 60 Hz.....	20
Part Load Ratings - Standard Efficiency	28
Part Load Ratings - High Efficiency.....	29
Physical Data - English.....	30
Dimensions - Four Fan Units.....	32
Dimensions - Five Fan Units	33
Dimensions - Six Fan Units	34
Dimensions - Eight Fan Units.....	35
Dimensions - Ten Fan Units	36
Isolator Locations.....	37
Isolator Details.....	40
Electrical Notes.....	43
Electrical Data w/o Pumps.....	44
Wiring Lugs.....	48
Electrical Data w/ Pumps.....	50
Wiring Diagram.....	60
Elementary Wiring	62
Condenser Fan Mapping and Sequencing.....	64
Compressor Wiring.....	65
Power Options Connection Diagram.....	66
Power Panel.....	67
Dual Pump Wiring.....	68
Wiring	69
MicroPanel Connections.....	70
Application Data.....	73
Guide Specifications.....	74

NOMENCLATURE

The model number denotes the following characteristics of the unit:



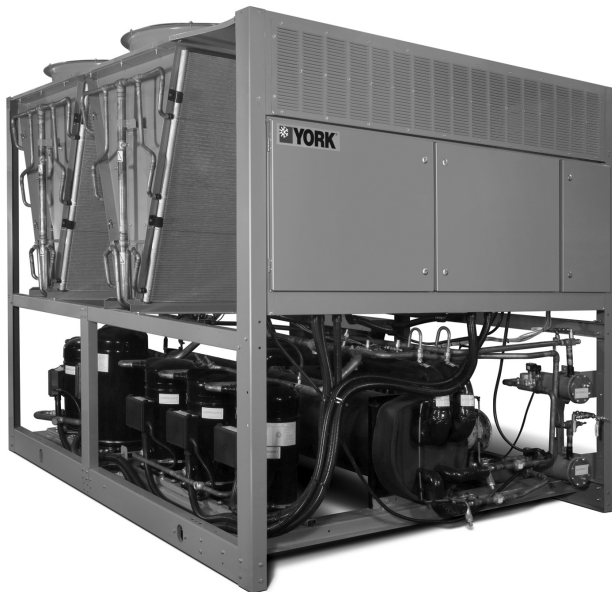

Tempo

**New Pace...New World
Try keeping up with our Tempo!**

*Johnson Controls, the leader in equipment controls and HVAC equipment is proud to offer the **YORK** air-cooled scroll chiller. This all-in-one package is a true plug and play system that provides superb efficiency*

and performance. The chiller is completely self-contained and is designed for outdoor (roof or ground level) installation. An optional hydronic pump kit makes service replacement or new building installations very convenient. Each unit includes zero-ozone-depletion refrigerant (R-410A), hermetic scroll compressors, a liquid evaporator, air cooled condenser, and a weather resistant microprocessor control center, all mounted on a formed steel base.

ENVIRONMENTAL RESPONSIBILITY ...STANDARD

TEMPO makes you the leader in environmental practices through innovation, not added cost. With the combination of R-410A refrigerant and a 30-50% reduction of refrigerant used vs. similar chillers, the TEMPO chiller provides you with the most ecologically friendly equipment. Partnered with its low sound properties (for noise pollution prevention), this chiller is a true earth-friendly offering.

REDUCED TOTAL COST OF OWNERSHIP...

Industry leading energy efficiency, easy maintenance and durability minimize your cost of ownership. Efficiency; environmental responsibility that pays you back...

- Real world energy efficiency is measured in IPLV (part load) performance
- Tempo's industry leading IPLV's deliver cash to your bottom line
- Serviceability...Easier maintenance pays twice: sustained chiller efficiency and lower cost maintenance contracts
- Corrosion resistant condenser coils extend life and improve performance

MORE BUILDING...LESS CHILLER

TEMPO offers a lighter, smaller and quieter chiller minimizing your installed cost and maximizing usable building space.

- More space for you
- Smaller chiller footprint saves valuable space
- Tempo is the lowest weight chiller available, lighter than our previous generation chiller by 20-35%
- Hydronic pump kit option can save both space and cost by integrating the chilled water pumps as a factory mounted chiller option
- Standard low sound and affordable sound attenuation options allow flexibility in locating chiller and reduce cost for field constructed sound barriers

MANY APPLICATIONS, ONE TEMPO!

Performance, sound and hydronic pump kits are all configurable to suit your many needs... Performance can be configured with standard and high full-load efficiency models (an industry first)

- Multiple sound configurations...only spend on what you need.
- Pumps can be factory mounted
- Hydronic pump kits can be configured for a wide range of flow and head pressure with single or dual (standby) pump
- Standard corrosion resistance for coastal applications
- Small weight and footprint allow you maximum choice in locating the chiller

Specifications

GENERAL

The 70 - 175 Ton (246 - 613) **YLAA** models are shipped complete from the factory ready for installation and use.

The unit is pressure-tested, evacuated, and fully charged with a zero Ozone Depletion Potential Refrigerant R-410A and includes an initial oil charge. After assembly, a complete operational test is performed with water flowing through the evaporator to assure that the refrigeration circuit operates correctly.

The unit structure is heavy-gauge, galvanized steel. This galvanized steel is coated with baked-on powder paint, which, when subjected to ASTM B117 1000 hour, salt spray testing, yields a minimum ASTM 1654 rating of "6". Units are designed in accordance with NFPA 70 (National Electric Code), ASHRAE/ANSI 15 Safety code for mechanical refrigeration, ASME and rated in accordance with ARI Standard 550/590.

COMPRESSORS

The chiller has suction-gas cooled, hermetic, scroll compressors. The YLAA compressors incorporate a compliant scroll design in both the axial and radial direction. All rotating parts are statically and dynamically balanced. A large internal volume and oil reservoir provides greater liquid tolerance. Compressor-crankcase heaters are also included for extra protection against liquid migration.

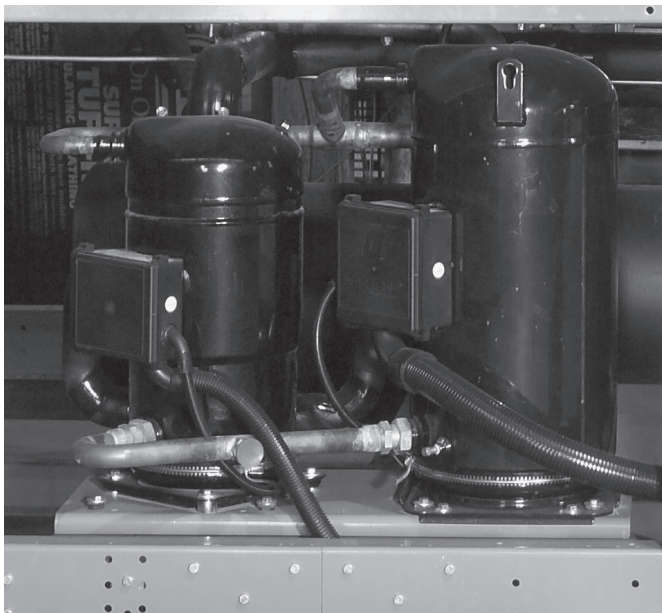

EVAPORATOR

The evaporator is equipped with a heater controlled by a separate thermostat. The heater provides freeze protection for the evaporator down to -20°F (-29°C) ambient. The evaporator is covered with 3/4" flexible, closed-cell, foam insulation (K=0.25).

The water baffles are constructed of galvanized steel to resist corrosion. The removable heads allow access to the internally enhanced, seamless, copper tubes. Vent and drain connections are included.



Water inlet and outlet connections are grooved for compatibility with field supplied ANSI/AWWA C-606 couplings.

CONDENSER

Coils - Condenser coils are made of a single material to avoid galvanic corrosion due to dissimilar metals. Coils and headers are brazed as one piece. Integral sub cooling is included. The design working pressure of the coil is 650 PSIG (45 bar). Condenser coil shall be pressure washable up to 1500 psi washer.

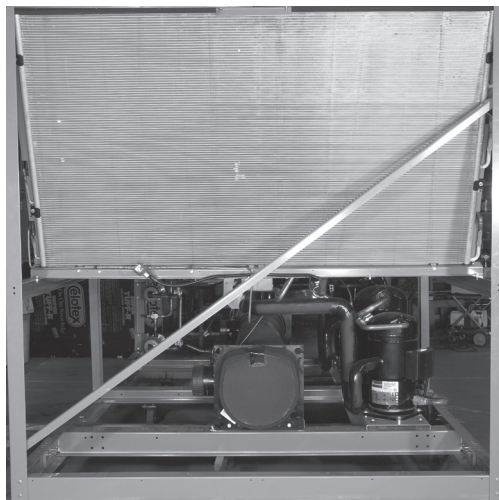

Fans - The condenser fans are composed of corrosion resistant aluminum hub and glass-fiber-reinforced polypropylene composite blades molded into a low-noise airfoil section. They are designed for maximum efficiency and are statically and dynamically balanced for vibration-free operation. They are directly driven by independent motors, and positioned for vertical air discharge. The fan guards are constructed of heavy-gauge, rust-resistant, coated steel. All blades are statically and dynamically balanced for vibration-free operation.

Motors - The fan motors are Totally Enclosed Air-Over, squirrel-cage type, current protected. They feature ball bearings that are double-sealed and permanently lubricated.

Ambient Kit (High) - Required if units are to operate when the ambient temperature is above 115°F (46°C). Includes discharge pressure transducers.

Microcomputer Control Center

All controls are contained in a NEMA 3R/12 cabinet with hinged outer door and includes:

Liquid Crystal Display with Light Emitting Diode back-lighting for outdoor viewing:

- Two display lines
- Twenty characters per line

Color coded 12-button non-tactile keypad with sections for:

DISPLAY/PRINT of typical information:

- Chilled liquid temperatures
- Ambient temperature
- System pressures (each circuit)
- Operating hours and starts (each compressor)

Print calls up to the liquid crystal display:
 Operating data for the systems
 History of fault shutdown data for up to the last six fault shutdown conditions
 An RS-232 port, in conjunction with this

press-to-print button, is provided to permit the capability of hard copy print-outs via a separate printer (by others).

ENTRY section to:

ENTER setpoints or modify system values

SETPOINTS updating can be performed to:

- Chilled liquid temperature setpoint and range
- Remote reset temperature range
- Set daily schedule/holiday for start/stop
- Manual override for servicing
- Low and high ambient cutouts
- Number of compressors
- Low liquid temperature cutout
- Low suction pressure cutout
- High discharge pressure cutout
- Anti-recycle timer (compressor start cycle time)
- Anti-coincident timer (delay compressor starts)

UNIT section to:

- Set time
- Set unit options

UNIT ON/OFF switch

The microprocessor control center is capable of displaying the following:

- Return and leaving liquid temperature
- Low leaving liquid temperature cutout setting
- Low ambient temperature cutout setting
- Outdoor air temperature
- English or Metric data
- Suction pressure cutout setting
- Each system suction pressure
- Discharge pressure (optional)
- Liquid Temperature Reset via a Johnson Controls ISN DDC or Building Automation System (by others) via:
 - a 4-20 milliamp or 0 -10 VDC input
- Anti-recycle timer status for each system
- Anti-coincident system start timer condition
- Compressor run status
- No cooling load condition
- Day, date and time
- Daily start/stop times
- Holiday status
- Automatic or manual system lead/lag control
- Lead system definition
- Compressor starts & operating hours

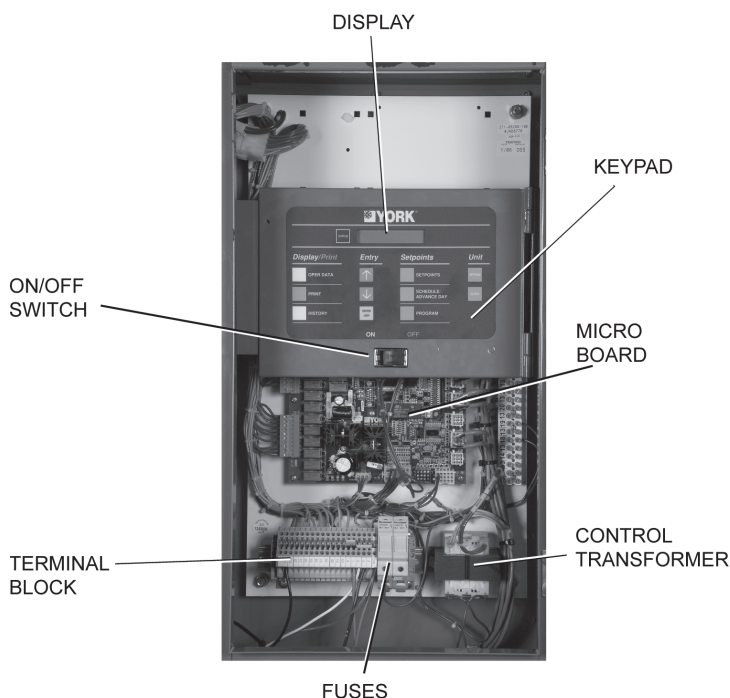

FIG.1 – CONTROL PANEL COMPONENTS

Microcomputer Control Center - continued

(each compressor)

- Status of hot gas valves, evaporator heater and fan operation
- Run permissive status
- Number of compressors running
- Liquid solenoid valve status
- Load & unload timer status
- Water pump status

Provisions are included for: pumpdown at shutdown; optional remote chilled water temperature reset and two steps of demand load limiting from an external building automation system. Unit alarm contacts are standard. The operating program is stored in non-volatile memory (EPROM) to eliminate chiller failure due to AC powered failure/battery discharge. Programmed setpoints are retained in lithium battery-backed RTC memory for 5 years minimum.

COMMUNICATIONS

- Native communication capability for BACnet (MS/TP) and Modbus
- Optional communication available for N2 and LON via eLink option

HIGH AMBIENT KIT

Allows units to operate when the ambient temperature is above 115°F (46°C). Includes sun shield panels and

discharge pressure transducers.

BUILDING AUTOMATION SYSTEM INTERFACE

The factory addition of a Printed Circuit Board to accept a 4-20 milliamp or 0-10VDC input to reset the leaving chiller liquid temperature from a Building Automation System. **(Factory-mounted)**

- (The standard unit capabilities include remote start-stop, remote water temperature reset via up to two steps of demand (load) limiting depending on model.)
- (The standard control panel can be directly connected to a Johnson Controls Building Automated System via the standard on-board RS232 communication port.)

POWER PANEL

Each panel contains:

- Compressor power terminals
- Compressor motor starting contactors per I.E.C.
- Control power terminals to accept incoming for 115-1-60 control power
- Fan contactors & overload current protection

The power wiring is routed through liquid-tight conduit to the compressors and fans.

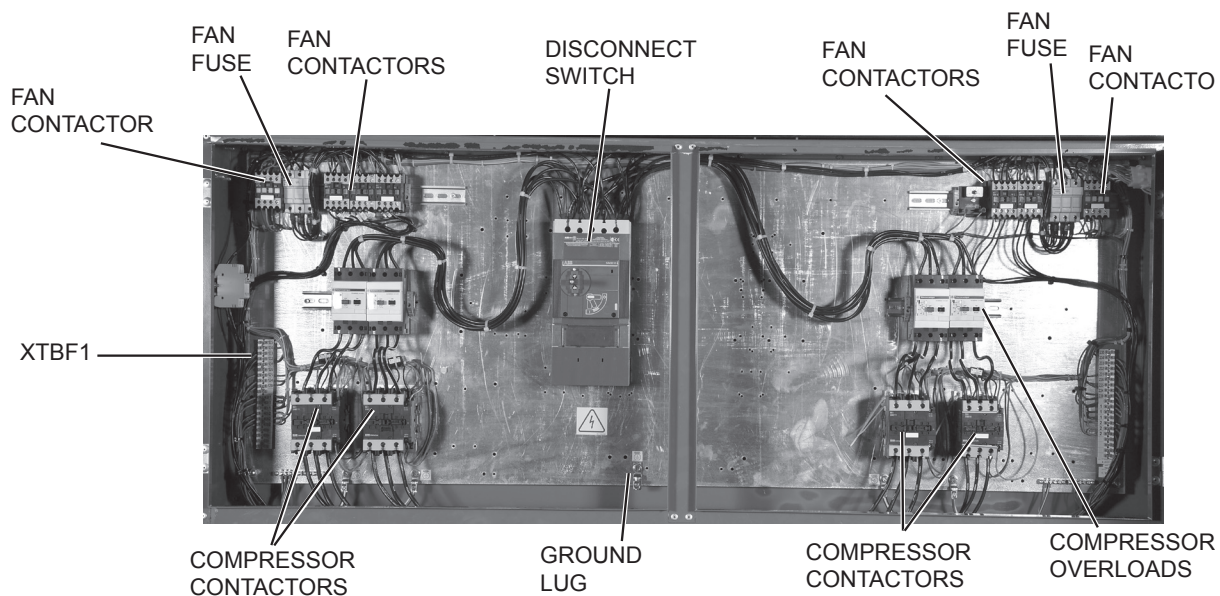

FIG. 2 – POWER PANEL COMPONENTS

Accessories and Options

POWER OPTIONS:

COMPRESSOR POWER CONNECTIONS – Single-point terminal block connection(s) are provided as standard. The following power connections are available as options. (See electrical data for specific voltage and options availability.) **(Factory-mounted)**

SINGLE-POINT SUPPLY TERMINAL BLOCK – Includes enclosure, terminal-block and interconnecting wiring to the compressors. Separate external protection must be supplied, by others, in the incoming compressor-power wiring. (Do not include this option if either the Single-Point Non-Fused Disconnect Switch or Single-Point Circuit Breaker options have been included.)

SINGLE-POINT NON-FUSED DISCONNECT SWITCH – Unit-mounted disconnect switch(es) with external, lockable handle (in compliance with Article 440-14 of N.E.C.), can be supplied to isolate the unit power voltage for servicing. Separate external fusing must be supplied, by others in the power wiring, which must comply with the National Electrical Code and/or local codes.

SINGLE-POINT NON-FUSED DISCONNECT SWITCH WITH INDIVIDUAL SYSTEM BREAKERS - Includes unit-mounted disconnect switch with external, lockable handles (in compliance with Article 440-14 of N.E.C.) to isolate unit power voltage for servicing. Factory interconnecting wiring is provided from the disconnect switch to factory supplied system circuit breakers.

SINGLE-POINT CIRCUIT BREAKER – A unit mounted circuit breaker with external, lockable handle (in compliance with N.E.C. Article 440-14), can be supplied to isolate the power voltage for servicing. (This option includes the Single-Point Power connection.)

CONTROL TRANSFORMER – Converts unit power voltage to 115-1-60 (0.5 or 1.0 KVA capacity). Factory mounting includes primary and secondary wiring between the transformer and the control panel. **(Factory-mounted)**

POWER FACTOR CORRECTION CAPACITORS – Will correct unit compressor power factors to a 0.90-0.95. **(Factory-mounted)**

CONTROL OPTIONS:

AMBIENT KIT (LOW) – Units will operate to 30°F (-1°C). This accessory includes all necessary components to permit chiller operation to 0°F (-18°C). (*This option includes the Discharge Pressure Transducer / Readout Capability option.*) For proper head pressure control in applications below 30°F (-1°C) where wind gusts may exceed 5 mph,

it is recommended that Optional Condenser Louvered Enclosure Panels also be included. **(Factory-mounted)**

LANGUAGE LCD AND KEYPAD DISPLAY – Spanish, French, German, and Italian unit LCD controls and keypad display available. Standard language is English.

COMPRESSOR, PIPING, EVAPORATOR OPTIONS:

FLANGES (ANSI/AWWA C-606 COUPLINGS TYPE) – Consists of (2) Flange adapter for grooved end pipe (standard 150 psi [10.5 bar] evaporator). (*Not available on optional DX evaporator 300 PSIG DWP waterside.*) **(Field-mounted)**

LOW TEMPERATURE BRINE – Required for brine chilling below 30°F (-1°C) leaving brine temperature. Option includes resized thermal expansion valve. **(Factory-mounted)**

CHICAGO CODE RELIEF VALVES – Unit will be provided with relief valves to meet Chicago code requirements. **(Factory-Mounted)**

SERVICE SUCTION ISOLATION VALVE – Service suction discharge (ball-type) isolation valves are added to unit per system (discharge service ball-type isolation valve is standard on each circuit). **(Factory-Mounted)**

HOT GAS BY-PASS – Permits continuous, stable operation at capacities below the minimum step of compressor unloading to as low as 5% capacity (depending on both the unit and operating conditions) by introducing an artificial load on the evaporator. Hot gas by-pass is installed on only refrigerant system #1 on two-circuited units. **(Factory-Mounted)**

FLOW SWITCH – The flow switch or its equivalent must be furnished with each unit.

150 psig (10.5 bar) DWP – For standard units. Johnson Controls model F61MG-1C Vapor-proof SPDT, NEMA 3R switch (150 PSIG [10.5 bar] DWP), -20°F to 250°F (-29°C to 121°C), with 1" NPT connection for upright mounting in horizontal pipe. **(Field-mounted)**

DIFFERENTIAL PRESSURE SWITCH – Alternative to an above mentioned flow switch. Pretempco model DPS300A-P40PF-82582-5 (300 psi max. working pressure), SPDT 5 amp 125/250VAC switch, Range 3 - 40 PSID, deadband 0.5 - 0.8 psi, with 1/4" NPTE Pressure Connections.

HYDRO-KIT – Factory installed Hydro-Kit suitable for water glycol systems with up to 35% glycol at leaving tempera-

Accessories and Options - continued

tures down to 20 F. The Hydro-kit option is available in a single or dual configuration (dual as standby duty only), with totally enclosed permanently lubricated pump motors.

The hydro-kit option comes standard with a balancing valve, flow switch, pressure ports, suction guide, strainer, bleed and drain valves and frost protection.

Expansion tanks are optional within the Hydro-Kit option.

CONDENSER AND CABINET OPTIONS:

Condenser coil protection against corrosive environments is available by choosing any of the following options. For additional application recommendations, refer to FORM 150.12-ES1. **(Factory-Mounted)**

POST-COATED DIPPED CONDENSER COILS – The unit is built with dipped-cured condenser coils. This is the choice for corrosive applications (with the exception of strong alkalis, oxidizers and wet bromine, chlorine and fluorine in concentrations greater than 100 ppm).

ENCLOSURE PANELS (UNIT) – Tamperproof Enclosure Panels prevent unauthorized access to units. Enclosure Panels can provide an aesthetically pleasing alternative to expensive fencing. Additionally, for proper head pressure control, Johnson Controls recommends the use of Condenser Louvered Panels for winter applications where wind gusts may exceed five miles per hour. The following types of enclosure panels are available:

WIRE PANELS (FULL UNIT) – Consists of welded wire-mesh guards mounted on the exterior of the unit. Prevents unauthorized access, yet provides free air flow. **(Factory-Mounted)**

WIRE/LOUVERED PANELS – Consists of welded wire-mesh panels on the bottom part of unit and louvered panels on the condenser section of the unit. **(Factory-mounted)**.

LOUVERED PANELS (CONDENSER COIL ONLY) – Louvered panels are mounted on the sides and ends of the condenser coils for protection. **(Factory-Mounted)**

LOUVERED PANELS (FULL UNIT) – Louvered panels surround the front, back, and sides of the unit. They prevent unauthorized access and visually screen unit components. Unrestricted air flow is permitted through generously sized louvered openings. This option is applicable for any outdoor design ambient temperature up to 115°F (46°). **(Factory-Mounted)**

COIL END HAIL GUARD – Louvered panel attached to exposed coil end. **(Factory-Mounted)**

SOUND ATTENUATION – One or both of the following sound attenuation options are recommended for residential or other similar sound sensitive locations:

COMPRESSOR ACOUSTIC SOUND BLANKET – Each compressor is individually enclosed by an acoustic sound blanket. The sound blankets are made with one layer of acoustical absorbent textile fiber of 5/8" (15mm) thickness; one layer of anti-vibrating heavy material thickness of 1/8" (3mm). Both are closed by two sheets of welded PVC, reinforced for temperature and UV resistance. **(Factory-Mounted)**



ULTRA QUIET FANS – Lower RPM, 8-pole fan motors are used with steeper-pitch fans. **(Factory-Mounted)**

VIBRATION ISOLATORS – Level adjusting, spring type 1" (25.4mm) or seismic deflection or neoprene pad isolators for mounting under unit base rails. **(Field-mounted)**

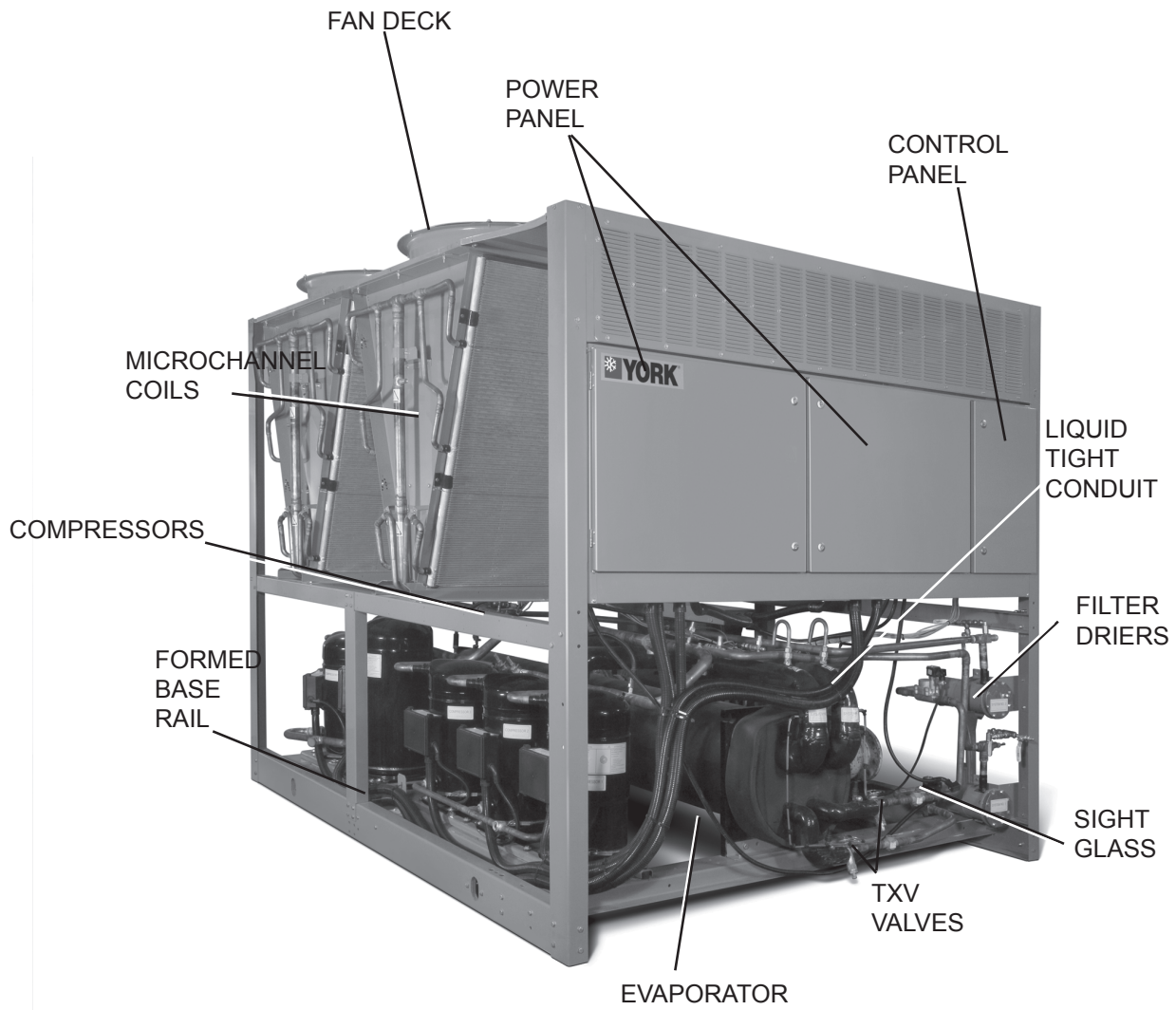

FIG.3 – GENERAL UNIT COMPONENTS

Design Parameters

Nominal Evaporator Water Flow						
Unit Designation	Temperature (°F)		Water Flow (gpm)		Air On Condenser (°F)	
	MIN ¹	MAX ²	MIN	MAX	MIN ³	MAX ⁴
YLAA0070SE	40	55	60	285	0	125
YLAA0080SE	40	55	100	355	0	125
YLAA0090SE	40	55	140	625	0	125
YLAA0100SE	40	55	100	385	0	125
YLAA0115SE	40	55	100	385	0	125
YLAA0120SE	40	55	150	625	0	125
YLAA0135SE	40	55	120	625	0	125
YLAA0150SE	40	55	120	625	0	125
YLAA0155SE	40	55	150	625	0	125
YLAA0170SE	40	55	120	625	0	125
High Efficiency						
YLAA0091HE	40	55	100	385	0	125
YLAA0101HE	40	55	100	385	0	125
YLAA0125HE	40	55	100	385	0	125
YLAA0141HE	40	55	150	625	0	125
YLAA0156HE	40	55	120	625	0	125
YLAA0175HE	40	55	180	650	0	125

NOTES:

1. For leaving brine temperature below 40°F (4°C), contact your nearest Johnson Controls Office for application requirements.
2. For leaving water temperature higher than 55°F (13°C), contact the nearest Johnson Controls Office for application guidelines. 3. The evaporator is protected against freezing to -20°F (-29°C) with an electric heater as standard.
3. For operation at temperatures below 30°F (-1°C), the optional Low Ambient Kit will need to be installed on the system (for YLAA00140080 models only).
4. For operation at temperatures above 115°F (46°C), the optional High Ambient Kit will need to be installed on the system.

Water Pressure Drop

YLAA Evaporator Pressure Drop (IP Units)

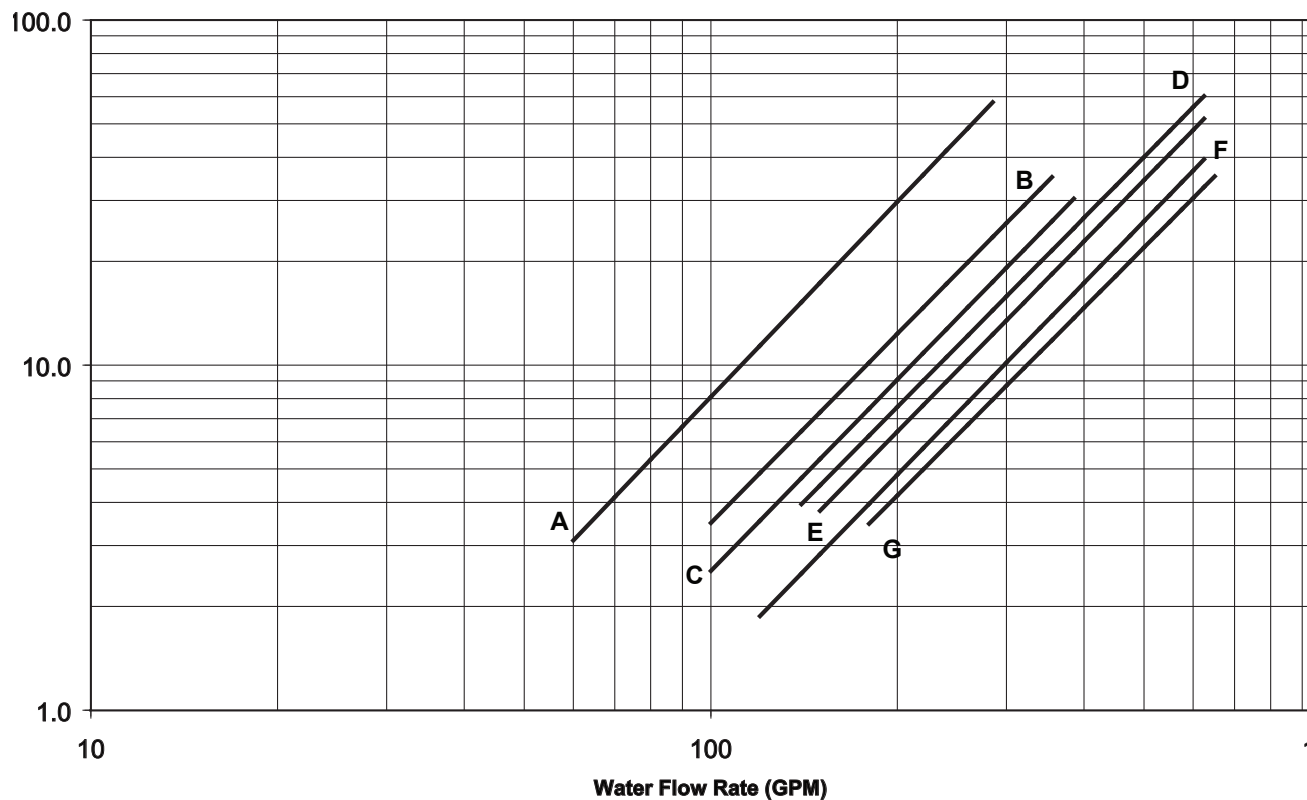

EVAPORATOR	YLAA MODELS
A	70SE
B	80SE
C	91HE, 100SE, 101HE, 115SE, 125HE
D	120SE, 141HE, 155SE
E	90SE
F	135SE, 150SE, 156HE, 170HE
G	175HE

Selection Criteria and Procedures

GUIDE TO SELECTION

Capacity ratings for **YORK** YLAA Packaged Air-Cooled Liquid Chillers, shown on pages 18 through 23 cover the majority of design applications for these units. For unusual applications or uses beyond the scope of this catalog, please consult your nearest Johnson Controls Office or representative.

SELECTION RULES

1. Ratings – Ratings may be interpolated, but must not be extrapolated. The Ratings given on pages 18 through 23 and the DESIGN PARAMETERS given on page 10 indicate the limits of application for these chillers.
2. Evaporator Water – Ratings are based upon 2.4 GPM per ton which is equal to a 10°F chilled water range and a 0.0001 fouling factor for the evaporator at sea level. Tables on pages 18 through 23 give capacity, compressor kW required, evaporator GPM and unit EER.
3. Condenser – Ratings are given in terms of air on condenser in degrees Fahrenheit.
4. Performance Data Correction Factors – Ratings are based on 0.0001 evaporator fouling factor, 10°F chilled water range and at sea level. For operation at different conditions, apply the appropriate correction factor from the following table.

FOULING FACTOR

ALTITUDE	TEMP SPLIT	0.0001		0.00025	
		TONS	COMPR kW	TONS	COMPR kW
SEA LEVEL	8	0.994	0.999	0.991	0.998
	10	1.000	1.000	0.993	0.999
	12	1.005	1.001	0.999	0.999
	14	1.008	1.002	1.005	1.000
2000 FT.	8	0.990	1.010	0.984	1.009
	10	0.995	1.010	0.990	1.009
	12	0.999	1.011	0.995	1.010
	14	1.004	1.015	0.998	1.011
4000 FT.	8	0.983	1.021	0.977	1.020
	10	0.989	1.024	0.983	1.021
	12	0.994	1.025	0.988	1.024
	14	0.997	1.026	0.993	1.025
6000 FT.	8	0.978	1.035	0.973	1.034
	10	0.982	1.037	0.978	1.035
	12	0.987	1.037	0.980	1.036
	14	0.992	1.038	0.986	1.037

6. Ethylene Glycol Correction Factors – The following factors are to be applied to the standard ratings for units cooling ethylene glycol.

ETHYLENE GLYCOL

% WEIGHT	TONS kW	COMPR	GPM°F/ TON	PRESS DROP	FREEZE PT
10	0.985	0.997	24.1	1.034	26
20	0.981	0.996	24.9	1.062	16
30	0.974	0.995	26.1	1.096	5
40	0.966	0.991	27.5	1.134	-10
50	0.957	0.989	29.1	1.172	-32

7. Propylene Glycol Correction Factors – The following factors are to be applied to the standard ratings for units cooling propylene glycol.

PROPYLENE GLYCOL

% WEIGHT	TONS kW	COMPR	GPM°F/ TON	PRESS DROP	FREEZE PT
10	0.983	0.996	24.2	1.048	27
20	0.974	0.995	24.4	1.086	19
30	0.961	0.990	25.1	1.134	8
40	0.946	0.98	26.0	1.186	-5
50	0.928	0.984	27.2	1.247	-25

METHOD OF SELECTION

To select a Johnson Controls - YLAA Packaged Air-Cooled Liquid Chiller, the following data must be known:

1. Design Capacity in tons refrigeration (TR).
2. Entering and Leaving Liquid Temperatures.
3. Outside ambient air temperature in degrees F.
4. GPM of chilled liquid.

Determine capacity requirements from the following formula:

EXAMPLE – WATER CHILLING

1. GIVEN: Provide a capacity of 90 Tons at 42°F leaving water 10°F range, 0.0001FF, 80°F air on the condenser, at sea level and 60 Hz.
2. FIND: Unit Size Compressor kW Input
3. From the Ratings on pages 18 - 23:
SELECT: YLAA0090SE (English Units)
 91.4 Tons
 82 Compressor KW
 12.4 Unit EER
4. Calculate Compressor kW at 50 Tons:
 $kW = (90-91.4) \times 80.7 = 80.7 \text{ kW}$

5. Calculate GPM:

$$\text{GPM} = \frac{90 \text{ Tons} \times 24}{216 \text{ GPM}}$$

10°F Range

6. From Page 10, read 10 ft of water evaporator pressure drop for GPM:
7. A YLAA0090 is suitable.

EXAMPLE – BRINE CHILLING

1. **GIVEN:** Provide a capacity of 80 tons cooling 30% by weight Ethylene Glycol from 50°F to 40°F, 0.00025FF, 95°F air on the condenser, 60 Hz and 4000 altitude.
2. **DETERMINE:**
Unit Size kW Input
Ethylene Glycol GPM Evaporator Pressure Drop
3. See Ethylene Glycol correction factors, for 30% by weight Ethylene Glycol.
READ: .974 Tons factor
.995 Compr. kW factor 26.1 Gal./°F/Tons factor
4. See Performance Data Correction Factors for 0.00025 fouling factor and 4000 ft. altitude.
READ: .983 Tons factor 1.021 kW factor

5. From RATINGS on pages 18 - 23:

SELECT: YLAA0090 (English Units)

91.4 Tons 82.0 Compressor kW

6. Determine YLAA0090 brine cooling capacity and Compressor kW requirement:
 - A. Tons = 91.4 x .974 x .983 = 87.51
 - B. Compr. kW = 82.0 x .995 x 1.021 = 83.3
 Determine average full load Compressor kW at 80 tons: (80/87.51) x 83.3 = 76.15kW
8. Determine Ethylene Glycol GPM:
Tons x Gal. °F/min/Ton factor
GPM = Range 80.0 x 26.1

GPM = 10 GPM = 208.8
9. Determine Evaporator Pressure Drop:
 - A. See Ethylene Glycol correction factors for 30% by weight Ethylene Glycol.
READ: 1.096 Pressure Drop Factor
 - B. See pages 18-19 at 88.7 GPM for the YLAA0090. READ: 6.8 Ft. H2O Pressure Drop
 - C. Evaporator Pressure Drop = 6.8 x 1.096 or 7.5 Ft. H2O
10. YLAA0090 is suitable.

Pump Selection Criteria

PUMP SELECTION

Multiple pump sizes are available for each YLAA model providing the ability to closely match the system requirements. Within the YORKworks CE chiller selection program is an integral pump selection program that can be used for a quick and easy pump selection. Please contact your local Johnson Controls sales rep for assistance with this selection program. If this program is not available or if a manual selection is desired, the following steps can be followed to make a pump selection for the hydro kit option.

1. Determine whether a single pump or dual pump (standby) option is required.

For this example, single pump hydro kits will be used.

2. Determine the required flow (GPM). This value will be calculated with the chiller selection. Pump design flow must be within the limits of the chiller.

ex. 100 Ton Chiller: 235 gpm (YLAA 0101HE) single pump option

3. Calculate the external system pressure loss (ft) for all piping and components external to the chiller.

ex. 45 ft

4. Determine the internal pressure loss to the chiller (ft) due to the evaporator from the Water Pressure Drop charts. Combine this with the external system pressure loss (ft) to determine the preliminary pressure loss.

ex. Internal Pressure Loss due to evaporator: 12 ft (from chart on page 11)
Preliminary pressure loss: 45 ft (external) + 12 ft (evaporator) = 57 ft

5. Review the available hydro kit options for the YLAA model (See Table 1) selected using the Hydro Kit by Models Chart. Use the flow and head calculated in steps 2 and 4 to select a preliminary design point. If the preliminary design point does not fall directly on the curve, select the next step larger size of impeller.

ex. Preliminary design point: 235 gpm/57 ft

Preliminary selection: Hydro Kit B/3x3x10@ 1740 rpm; 9.00 in impeller diameter with 7.5Hp motor.

6. Using the Hydro Kit pressure loss charts found on page 16-17, determine the internal pressure loss to

the chiller due to the hydro kit piping for the selected Hydro Kit. Add this to the preliminary pressure loss (from step 4) to determine the total pressure loss:

ex. For Hydro Kit B on YLAA0101 unit, the hydro kit pressure loss is 15 ft.

Total pressure loss = 57 ft + 15 ft = 72 ft

7. Check to see if the Hydro-Kit selection is valid. Using the total pressure loss (from step 6), plot the flow (GPM) and the total pressure loss on the hydro kit selected in step 5. If the pump selection is no longer adequate, re-select a hydro kit and go back to step 6. (Note: if a design point does not fall directly on the curve, one can select the next step larger size of impeller and use the circuit balancing valve to adjust the system head requirements and correct for small variations from the selected pump curve.) If the pump selection is satisfactory, proceed to step 8.

ex. Total Pressure Loss = 72ft. with GPM = 235
Selection is still valid for a Hydro-Kit B (3x3x10, 1800rpm, 9" impeller @ 7.5Hp)

8. The pump efficiency can be read from the pump curve using the dashed efficiency lines labeled as a percentage.

ex. Efficiency: 68 % (from pump curve)

9. The pump is selected

ex. Hydro Kit B at 68%

10. The pump NPSHr required can also be read from the pump curves. When selecting a pump one must make sure that the system designed NPSHa available is greater than the NPSHr required by the pump plus the fluid vapor pressure.

ex. NPSHr = 6 ft (From Pump Curve for Hydro Kit B)

NPSHa = 30 ft (From System Design - Figure 3)

VP = 0.4 ft (Water at 50°F)

NPSHr + VP < NPSHa

6 ft + 0.4 ft < 30 ft

If the system flow or pressure exceeds that of the hydro kit pump curves provided, an integral hydro kit is not available for your application and a separate pump must be provided.

TABLE1 – HYDRO KIT OPTIONS

Kit	Series	Kit Type	Pump Size	Pump HP	Motor RPM	Impeller Dia (in)	Models Where Used
A	4380	Single	3X3X8	5.0	1800	7.5	70,80,90,91
B	4380	Single	3X3X10	7.5	1800	9.0	70,80,90,91,101
C	4380	Single	3X3X10	10.0	1800	10.0	70,80,115,120,135
D	4380	Single	3X3X6	15.0	3600	5.9	70,80,90,91,101,115,120,135
E	4380	Single	3X3X8	20.0	3600	6.3	90,91,101,115,120,135
F	4380	Single	3X3X8	7.5	1800	8.0	101,115,120,135
G	4380	Single	4X4X8	10.0	1800	7.6	150,155
H	4380	Single	4X4X6	10.0	3600	4.9	150,155
I	4380	Single	4X4X6	15.0	3600	5.5	150,155
J	4380	Single	4X4X6	20.0	3600	6.0	150,155
K	4382	Dual	4X4X8	7.5	1800	7.9	70,80,90,91,101,115,120,135
L	4382	Dual	4X4X6	10.0	3600	5.3	70,80,90,91,101,115,150,155
M	4382	Dual	4X4X6	15.0	3600	5.6	70,80,90,91,120,135,150,155
N	4382	Dual	3X3X8	15.0	3600	6.6	70,80,90,91,
O	4382	Dual	4X4X6	15.0	3600	5.9	101,115,120,165
P	4382	Dual	3X3X8	20.0	3600	7.2	101,115,120
R	4382	Dual	4X4X8	20.0	3600	6.3	135,150,155

Pump Pressure Drop Curves

YLAA0070

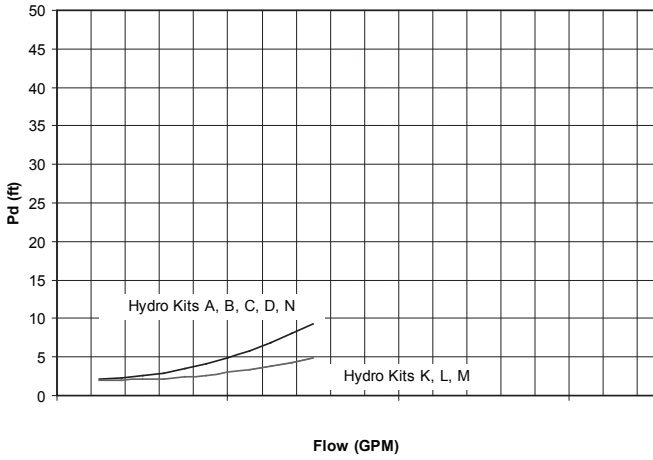

YLAA0080

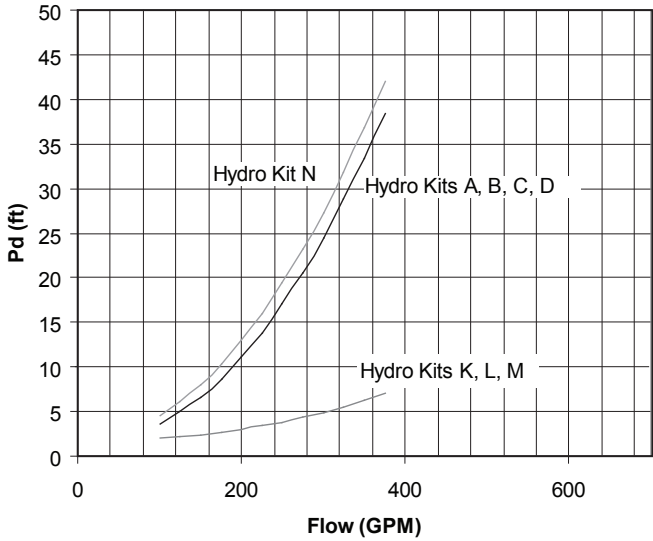

YLAA0090

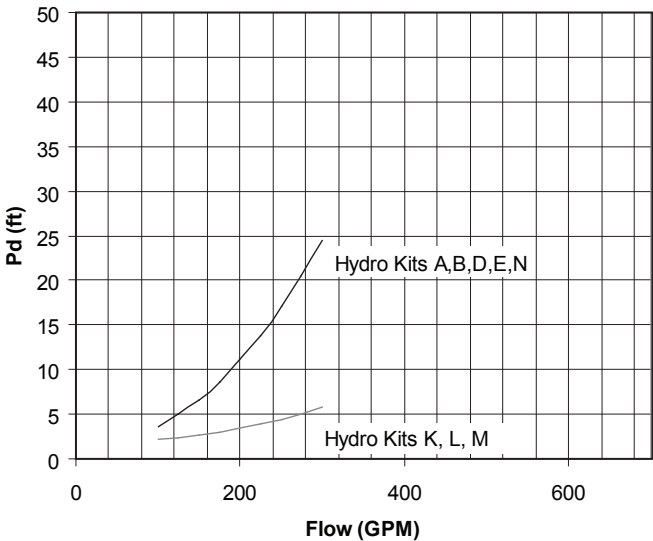

YLAA0091

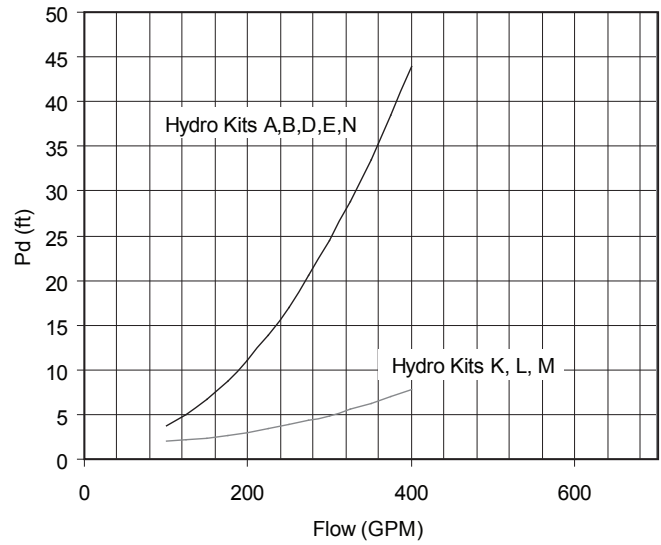

YLAA0101

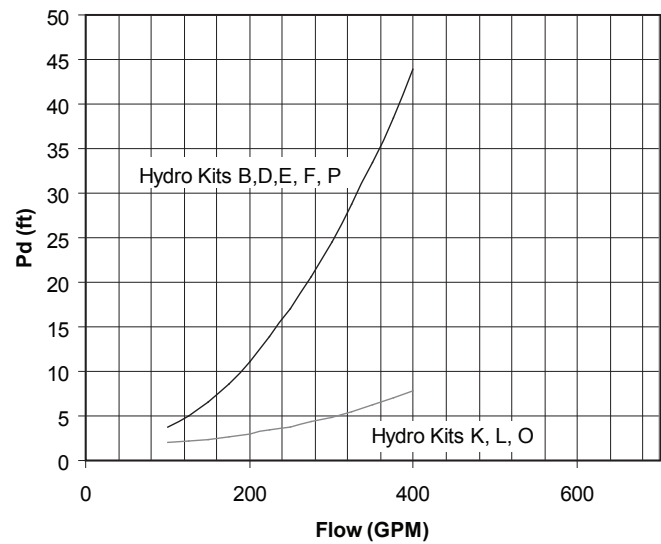

YLAA0115

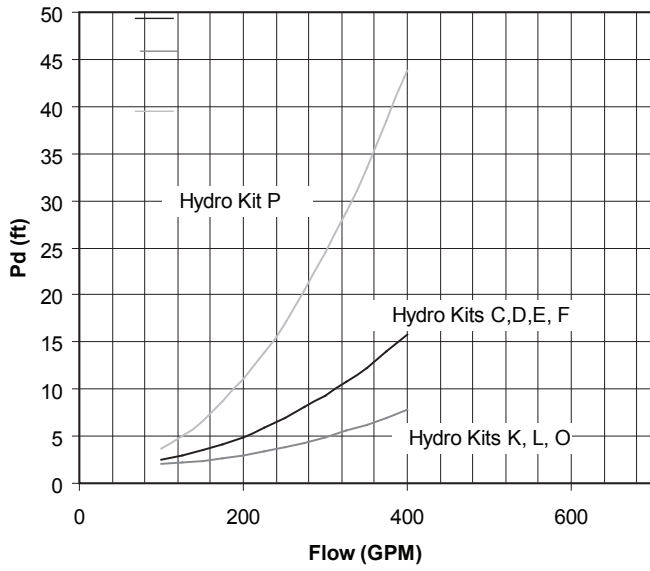

YLAA0150

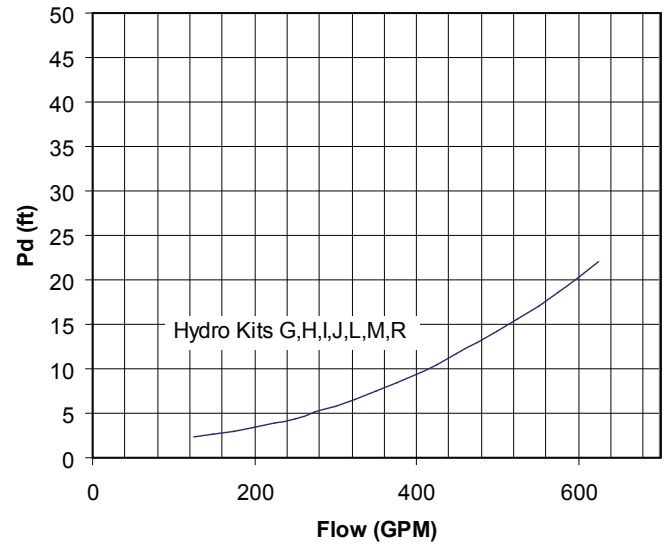

YLAA0120

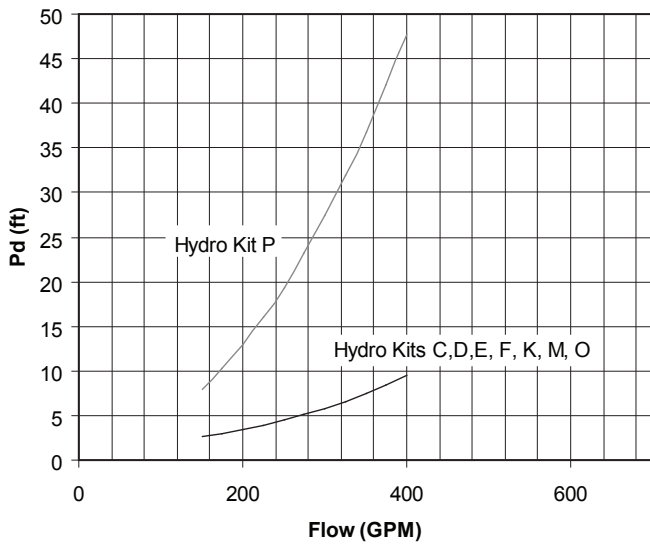

YLAA0155

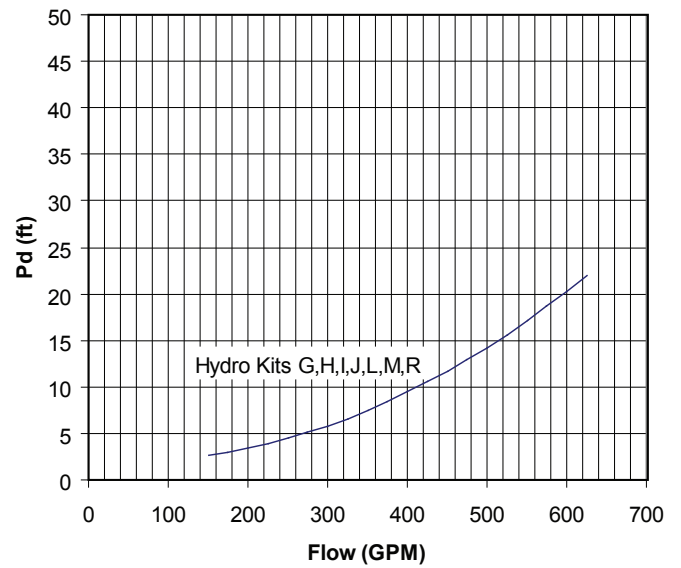

YLAA0135

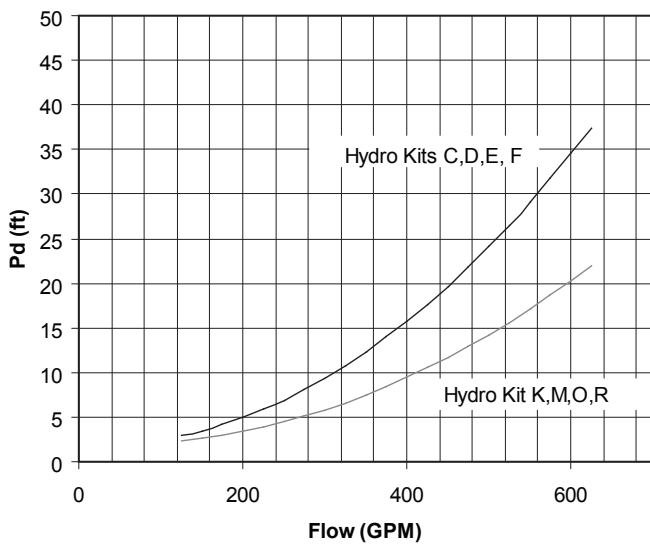

Single Pump Curves

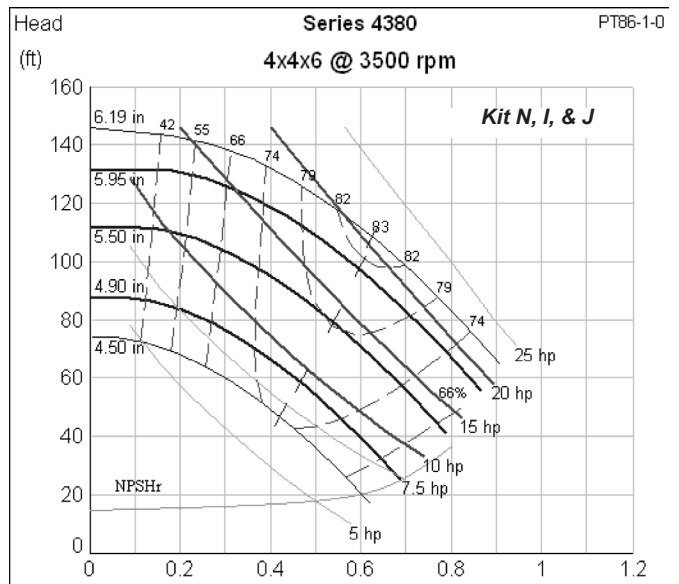
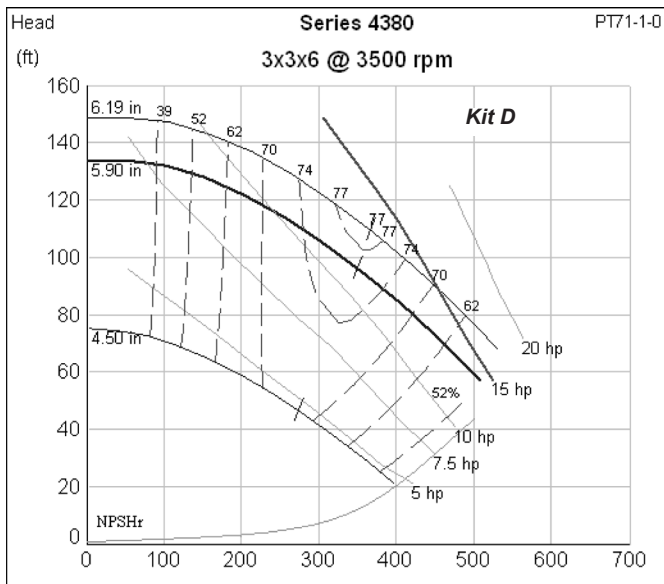
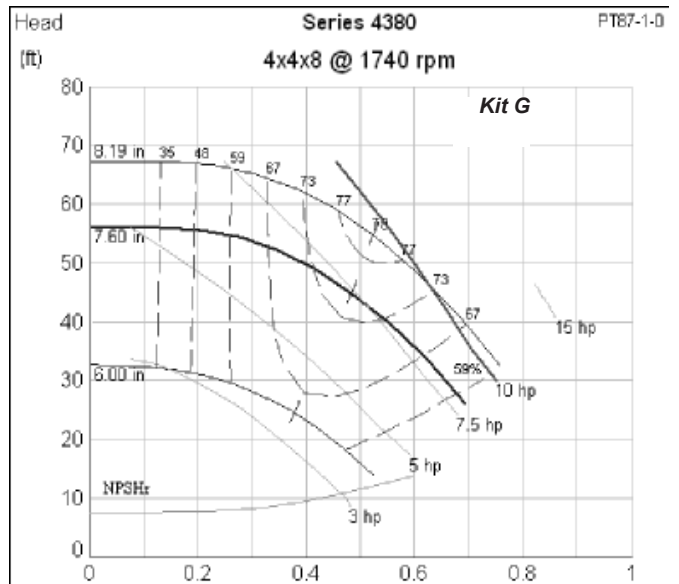
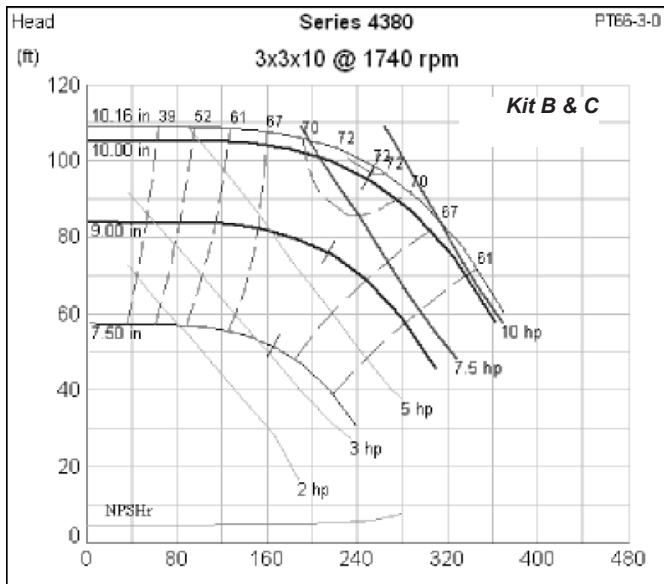
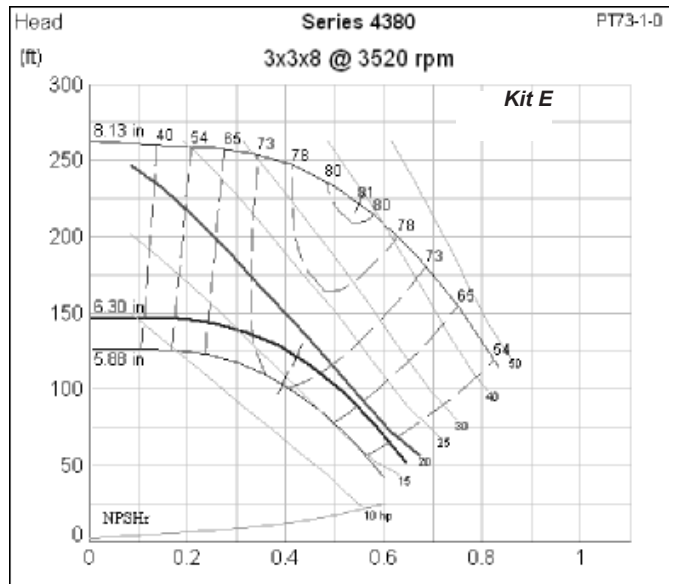
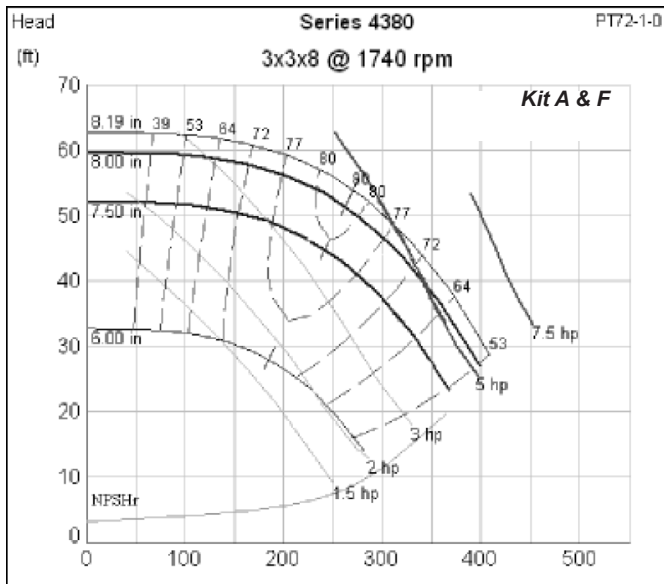

Dual Pump Curves

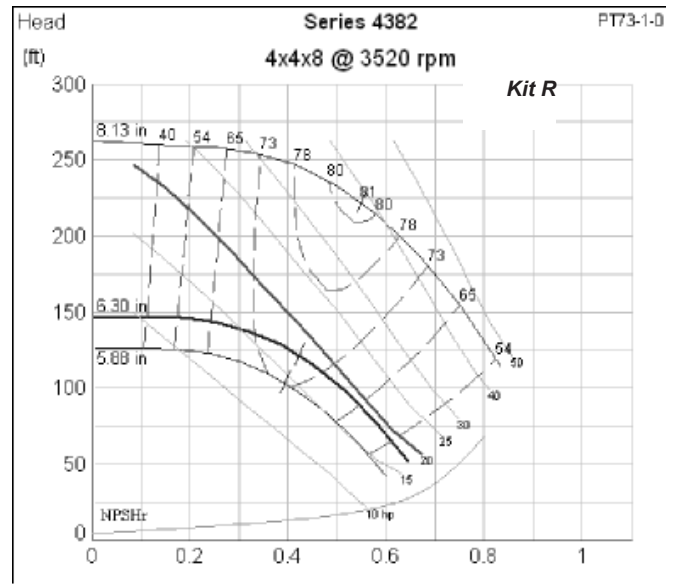
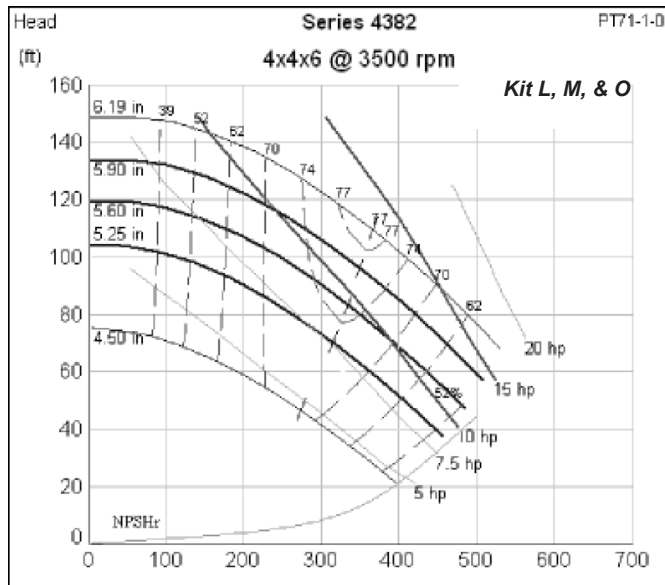
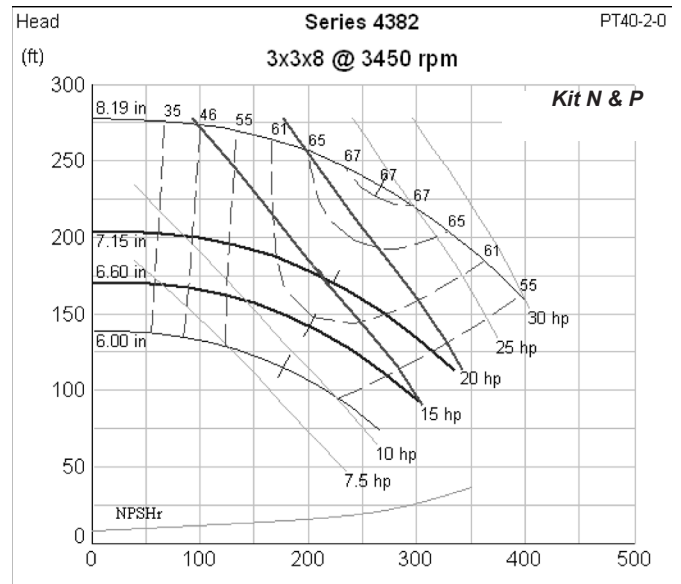
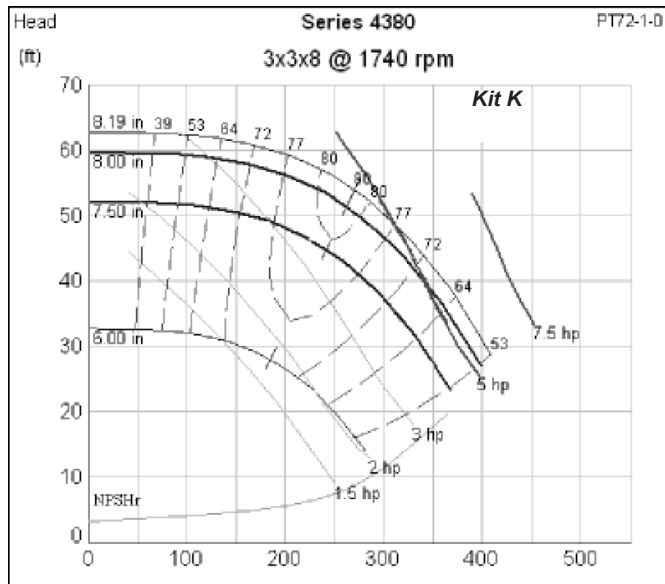

Ratings - 60 Hz

MODEL: YLAA0070SE IPLV= 15.1

AIR TEMPERATURE ON - CONDENSER (°F)																		
LCWT (°F)	75.0			80.0			85.0			90.0			95.0			100.0		
	TONS	KW	EER	TONS	KW	EER	TONS	KW	EER	TONS	KW	EER	TONS	KW	EER	TONS	KW	EER
40.0	69.3	59.9	12.5	67.6	63.2	11.6	65.7	66.7	10.7	63.9	70.5	9.9	61.9	74.5	9.1	59.6	78.5	8.4
42.0	71.6	60.5	12.8	69.8	63.8	11.9	67.9	67.3	11.0	65.9	71.1	10.2	63.9	75.1	9.4	61.5	79.1	8.6
44.0	73.9	61.1	13.1	72.0	64.4	12.1	70.1	68.0	11.3	68.1	71.7	10.4	66.0	75.8	9.6	63.5	79.7	8.8
45.0	75.0	61.4	13.2	73.1	64.7	12.3	71.2	68.3	11.4	69.1	72.1	10.5	67.0	76.1	9.7	64.5	80.1	8.9
46.0	76.2	61.8	13.4	74.3	65.0	12.4	72.3	68.6	11.5	70.2	72.4	10.7	68.1	76.4	9.8	65.5	80.4	9.0
48.0	78.6	62.4	13.6	76.6	65.7	12.7	74.5	69.2	11.8	72.4	73.0	10.9	70.2	77.1	10.1	67.6	81.0	9.2
50.0	81.1	63.0	13.9	79.0	66.3	13.0	76.8	69.9	12.0	74.6	73.7	11.1	72.4	77.7	10.3	69.7	81.7	9.5

MODEL: YLAA0080SE IPLV= 15.1

AIR TEMPERATURE ON - CONDENSER (°F)																		
LCWT (°F)	75.0			80.0			85.0			90.0			95.0			100.0		
	TONS	KW	EER	TONS	KW	EER	TONS	KW	EER	TONS	KW	EER	TONS	KW	EER	TONS	KW	EER
40.0	76.8	66.3	12.6	74.7	70.0	11.7	72.6	74.0	10.8	70.5	78.2	10.0	68.2	82.8	9.2	65.6	87.3	8.4
42.0	79.3	67.0	12.9	77.2	70.7	12.0	75.0	74.6	11.1	72.8	78.9	10.2	70.5	83.5	9.4	67.8	88.0	8.6
44.0	81.8	67.7	13.2	79.6	71.4	12.2	77.4	75.4	11.3	75.1	79.6	10.4	72.8	84.2	9.6	70.0	88.7	8.8
45.0	83.1	68.1	13.3	80.9	71.7	12.4	78.7	75.7	11.4	76.3	80.0	10.6	73.9	84.6	9.7	71.1	89.1	8.9
46.0	84.4	68.4	13.5	82.2	72.1	12.5	79.9	76.1	11.6	77.5	80.4	10.7	75.1	84.9	9.8	72.2	89.4	9.0
48.0	87.0	69.2	13.8	84.7	72.9	12.8	82.4	76.9	11.8	79.9	81.2	10.9	77.5	85.7	10.1	74.5	90.2	9.2
50.0	89.7	70.0	14.0	87.3	73.7	13.0	84.9	77.7	12.1	82.4	81.9	11.2	79.9	86.5	10.3	76.8	91.0	9.4

MODEL: YLAA0090SE IPLV= 15.5

AIR TEMPERATURE ON - CONDENSER (°F)																		
LCWT (°F)	75.0			80.0			85.0			90.0			95.0			100.0		
	TONS	KW	EER	TONS	KW	EER	TONS	KW	EER	TONS	KW	EER	TONS	KW	EER	TONS	KW	EER
40.0	91.0	76.9	13.1	88.5	81.0	12.1	85.9	85.5	11.2	83.2	90.3	10.3	80.4	95.4	9.4	77.1	100.4	8.6
42.0	94.0	77.8	13.3	91.4	82.0	12.4	88.7	86.5	11.4	85.9	91.3	10.5	83.1	96.4	9.7	79.7	101.4	8.8
44.0	96.9	78.7	13.6	94.3	82.9	12.6	91.5	87.4	11.7	88.7	92.2	10.8	85.8	97.3	9.9	82.4	102.4	9.1
45.0	98.4	79.2	13.7	95.7	83.4	12.7	92.9	87.9	11.8	90.1	92.7	10.9	87.2	97.8	10.0	83.7	102.9	9.2
46.0	100.0	79.7	13.9	97.2	83.9	12.9	94.4	88.5	11.9	91.5	93.2	11.0	88.6	98.3	10.1	85.1	103.4	9.3
48.0	103.0	80.7	14.1	100.2	84.9	13.1	97.3	89.5	12.1	94.3	94.3	11.2	91.4	99.4	10.3	87.7	104.4	9.5
50.0	106.1	81.8	14.4	103.2	86.0	13.4	100.2	90.6	12.4	97.2	95.4	11.4	94.2	100.4	10.5	90.5	105.5	9.7

MODEL: YLAA0091HE IPLV= 14.9

AIR TEMPERATURE ON - CONDENSER (°F)																		
LCWT (°F)	75.0			80.0			85.0			90.0			95.0			100.0		
	TONS	KW	EER	TONS	KW	EER	TONS	KW	EER	TONS	KW	EER	TONS	KW	EER	TONS	KW	EER
40.0	92.4	70.1	13.8	90.0	73.8	12.9	87.6	77.8	12.0	85.2	82.1	11.1	82.6	86.8	10.2	79.5	91.5	9.4
42.0	95.5	70.7	14.2	93.1	74.4	13.2	90.6	78.5	12.3	88.0	82.8	11.4	85.4	87.5	10.5	82.2	92.2	9.6
44.0	98.6	71.4	14.5	96.1	75.2	13.5	93.6	79.2	12.6	90.9	83.5	11.7	88.2	88.2	10.8	84.9	92.9	9.9
45.0	100.2	71.8	14.7	97.7	75.5	13.7	95.1	79.5	12.7	92.4	83.9	11.8	89.7	88.5	10.9	86.3	93.2	10.0
46.0	101.8	72.2	14.9	99.2	75.9	13.9	96.6	79.9	12.9	93.9	84.2	11.9	91.1	88.9	11.0	87.7	93.6	10.2
48.0	105.1	72.9	15.2	102.4	76.6	14.2	99.7	80.6	13.2	96.9	85.0	12.2	94.0	89.6	11.3	90.6	94.3	10.4
50.0	108.4	73.7	15.5	105.6	77.4	14.5	102.8	81.4	13.5	100.0	85.8	12.5	97.0	90.4	11.6	93.4	95.1	10.7

NOTES:

1. kW = Compressor Input Power
2. EER = Chiller EER (includes power from compressors, fans, and the control panels 0.8 kW)
3. LCWT = Leaving Chilled Water Temperature
4. Ratings are based upon 2.4 GPM evaporator water per ton and 0.0001 fouling factor
5. Rated in accordance with ARI Standard 550/590
6. The shaded points are certified in accordance with ARI Standard 550/590-98

MODEL: YLAA0070SE									IPLV= 15.1
AIR TEMPERATURE ON - CONDENSER (°F)									
LCWT (°F)	105.0			110.0			115.0		
	TONS	KW	EER	TONS	KW	EER	TONS	KW	EER
40.0	57.1	82.6	7.7	54.6	87.0	7.0	52.0	91.6	6.4
42.0	59.0	83.2	7.9	56.4	87.6	7.2	53.8	92.2	6.5
44.0	60.9	83.9	8.1	58.3	88.3	7.4	55.5	92.9	6.7
45.0	61.9	84.2	8.2	59.2	88.6	7.5	56.4	93.2	6.8
46.0	62.9	84.5	8.3	60.2	88.9	7.5	57.3	93.6	6.9
48.0	64.9	85.2	8.5	62.1	89.6	7.7	59.2	94.2	7.0
50.0	66.9	85.9	8.7	64.0	90.3	7.9	61.0	94.9	7.2

MODEL: YLAA0080SE									IPLV= 15.1
AIR TEMPERATURE ON - CONDENSER (°F)									
LCWT (°F)	105.0			110.0			115.0		
	TONS	KW	EER	TONS	KW	EER	TONS	KW	EER
40.0	62.9	92.0	7.6	60.1	96.9	7.0	48.9	80.4	6.7
42.0	65.0	92.7	7.8	62.1	97.7	7.1	50.6	80.9	6.9
44.0	67.1	93.4	8.0	64.1	98.4	7.3	52.3	81.4	7.1
45.0	68.2	93.8	8.1	65.2	98.8	7.4	53.2	81.7	7.2
46.0	69.2	94.2	8.2	66.2	99.2	7.5	54.1	82.0	7.3
48.0	71.4	95.0	8.4	68.3	100.0	7.7	55.9	82.6	7.5
50.0	73.7	95.8	8.6	70.5	100.8	7.9	57.8	83.2	7.7

MODEL: YLAA0090SE									IPLV= 15.5
AIR TEMPERATURE ON - CONDENSER (°F)									
LCWT (°F)	105.0			110.0			115.0		
	TONS	KW	EER	TONS	KW	EER	TONS	KW	EER
40.0	73.8	105.7	7.9	70.4	111.2	7.2	48.8	72.0	7.4
42.0	76.3	106.7	8.1	72.8	112.2	7.3	50.6	72.5	7.7
44.0	78.8	107.7	8.3	75.3	113.2	7.5	52.4	73.0	7.9
45.0	80.1	108.2	8.4	76.5	113.7	7.6	53.3	73.3	8.0
46.0	81.4	108.7	8.5	77.7	114.3	7.7	54.2	73.5	8.1
48.0	84.1	109.8	8.7	80.3	115.3	7.9	56.0	74.1	8.3
50.0	86.7	110.9	8.8	71.9	93.6	8.6	57.9	74.7	8.5

MODEL: YLAA0091HE									IPLV= 14.9
AIR TEMPERATURE ON - CONDENSER (°F)									
LCWT (°F)	105.0			110.0			115.0		
	TONS	KW	EER	TONS	KW	EER	TONS	KW	EER
40.0	76.3	96.4	8.6	73.1	101.5	7.9	69.8	107.0	7.2
42.0	78.9	97.1	8.8	75.6	102.2	8.1	72.2	107.7	7.4
44.0	81.6	97.8	9.1	78.2	103.0	8.3	74.7	108.4	7.6
45.0	82.9	98.1	9.2	79.5	103.3	8.4	76.0	108.8	7.7
46.0	84.3	98.5	9.3	80.8	103.7	8.5	77.2	109.2	7.8
48.0	87.0	99.2	9.6	83.4	104.4	8.7	79.8	109.9	8.0
50.0	89.8	100.0	9.8	86.1	105.2	9.0	82.4	110.7	8.2

NOTES:

1. kW = Compressor Input Power
2. EER = Chiller EER (includes power from compressors, fans, and the control panels 0.8 kW)
3. LCWT = Leaving Chilled Water Temperature
4. Ratings are based upon 2.4 GPM evaporator water per ton and 0.0001 fouling factor
5. Rated in accordance with ARI Standard 550/590
6. The shaded points are certified in accordance with ARI Standard 550/590-98

Ratings - 60 Hz - continued

MODEL: YLAA0100SE IPLV= 14.3

AIR TEMPERATURE ON - CONDENSER (°F)																		
LCWT (°F)	75.0			80.0			85.0			90.0			95.0			100.0		
	TONS	KW	EER	TONS	KW	EER	TONS	KW	EER	TONS	KW	EER	TONS	KW	EER	TONS	KW	EER
40.0	101.0	87.5	12.6	98.3	92.2	11.7	95.6	97.4	10.8	92.7	102.9	10.0	89.8	108.8	9.2	86.3	114.6	8.4
42.0	104.3	88.4	12.9	101.5	93.2	12.0	98.7	98.3	11.1	95.8	103.8	10.2	92.8	109.7	9.4	89.2	115.6	8.6
44.0	107.6	89.3	13.2	104.7	94.2	12.3	101.8	99.3	11.3	98.9	104.8	10.5	95.8	110.7	9.6	92.1	116.5	8.8
45.0	109.3	89.8	13.3	106.4	94.7	12.4	103.4	99.8	11.5	100.4	105.3	10.6	97.3	111.2	9.8	93.6	117.1	9.0
46.0	111.0	90.3	13.5	108.0	95.2	12.5	105.1	100.3	11.6	102.0	105.8	10.7	98.8	111.7	9.9	95.1	117.6	9.1
48.0	114.4	91.4	13.8	111.4	96.2	12.8	108.3	101.3	11.8	105.2	106.9	10.9	101.9	112.8	10.1	98.1	118.6	9.3
50.0	117.9	92.5	14.0	114.8	97.3	13.0	111.7	102.4	12.1	108.4	108.0	11.2	105.1	113.9	10.3	101.1	119.7	9.5

MODEL: YLAA0101HE IPLV= 15.4

AIR TEMPERATURE ON - CONDENSER (°F)																		
LCWT (°F)	75.0			80.0			85.0			90.0			95.0			100.0		
	TONS	KW	EER	TONS	KW	EER	TONS	KW	EER	TONS	KW	EER	TONS	KW	EER	TONS	KW	EER
40.0	103.5	83.9	13.2	100.8	88.5	12.3	98.1	93.4	11.4	95.2	98.7	10.5	92.3	104.4	9.7	88.8	110.0	8.9
42.0	106.9	84.7	13.5	104.1	89.3	12.6	101.3	94.2	11.7	98.4	99.6	10.8	95.4	105.2	9.9	91.8	110.9	9.1
44.0	110.3	85.6	13.8	107.5	90.2	12.9	104.6	95.1	11.9	101.6	100.4	11.0	98.5	106.1	10.2	94.8	111.8	9.3
45.0	112.1	86.0	14.0	109.2	90.6	13.0	106.3	95.5	12.1	103.2	100.9	11.2	100.1	106.6	10.3	96.3	112.2	9.5
46.0	113.8	86.5	14.1	110.9	91.1	13.2	107.9	96.0	12.2	104.8	101.3	11.3	101.7	107.0	10.4	97.9	112.7	9.6
48.0	117.4	87.4	14.5	114.4	92.0	13.4	111.3	97.0	12.5	108.2	102.3	11.6	104.9	108.0	10.7	101.0	113.6	9.8
50.0	121.1	88.4	14.8	118.0	93.0	13.7	114.8	98.0	12.7	111.5	103.3	11.8	108.2	109.0	10.9	104.2	114.6	10.0

MODEL: YLAA0115SE IPLV= 14.6

AIR TEMPERATURE ON - CONDENSER (°F)																		
LCWT (°F)	75.0			80.0			85.0			90.0			95.0			100.0		
	TONS	KW	EER	TONS	KW	EER	TONS	KW	EER	TONS	KW	EER	TONS	KW	EER	TONS	KW	EER
40.0	120.1	104.1	12.6	117.0	109.6	11.7	113.7	115.6	10.9	110.4	122.0	10.0	106.9	128.7	9.2	102.8	135.3	8.5
42.0	123.9	105.3	12.9	120.7	110.9	12.0	117.4	116.8	11.1	113.9	123.2	10.3	110.4	129.9	9.5	106.2	136.5	8.7
44.0	127.9	106.5	13.2	124.5	112.1	12.2	121.1	118.0	11.3	117.6	124.4	10.5	113.9	131.1	9.7	109.6	137.8	8.9
45.0	129.9	107.1	13.3	126.5	112.7	12.4	123.0	118.6	11.5	119.4	125.0	10.6	115.7	131.8	9.8	111.3	138.4	9.0
46.0	131.8	107.7	13.4	128.4	113.3	12.5	124.9	119.3	11.6	121.2	125.7	10.7	117.5	132.4	9.9	113.0	139.1	9.1
48.0	135.9	108.9	13.7	132.3	114.6	12.7	128.7	120.5	11.8	124.9	127.0	10.9	121.1	133.7	10.1	116.5	140.4	9.3
50.0	140.0	110.2	14.0	136.3	115.9	13.0	132.6	121.9	12.1	128.7	128.3	11.2	124.8	135.1	10.3	120.0	141.8	9.5

MODEL: YLAA0120SE IPLV= 14.8

AIR TEMPERATURE ON - CONDENSER (°F)																		
LCWT (°F)	75.0			80.0			85.0			90.0			95.0			100.0		
	TONS	KW	EER	TONS	KW	EER	TONS	KW	EER	TONS	KW	EER	TONS	KW	EER	TONS	KW	EER
40.0	126.7	106.1	13.1	123.2	111.7	12.1	119.7	117.5	11.3	116.0	123.9	10.4	112.3	130.5	9.6	107.8	137.1	8.8
42.0	130.8	107.3	13.4	127.2	112.9	12.4	123.6	118.8	11.5	119.8	125.2	10.6	115.9	131.9	9.8	111.4	138.4	9.0
44.0	135.0	108.6	13.6	131.3	114.2	12.7	127.5	120.1	11.8	123.6	126.5	10.9	119.7	133.2	10.0	115.0	139.8	9.2
45.0	137.1	109.3	13.8	133.3	114.9	12.8	129.5	120.8	11.9	125.6	127.2	11.0	121.5	133.9	10.1	116.8	140.5	9.3
46.0	139.2	110.0	13.9	135.4	115.6	12.9	131.5	121.5	12.0	127.5	127.9	11.1	123.4	134.6	10.2	118.6	141.2	9.4
48.0	143.4	111.3	14.2	139.5	117.0	13.2	135.6	122.9	12.2	131.4	129.3	11.3	127.3	136.0	10.5	122.3	142.6	9.6
50.0	147.7	112.7	14.4	143.7	118.4	13.4	139.6	124.5	12.4	135.4	130.8	11.5	131.1	137.5	10.7	126.0	144.1	9.8

NOTES:

1. kW = Compressor Input Power
2. EER = Chiller EER (includes power from compressors, fans, and the control panels 0.8 kW)
3. LCWT = Leaving Chilled Water Temperature
4. Ratings are based upon 2.4 GPM evaporator water per ton and 0.0001 fouling factor
5. Rated in accordance with ARI Standard 550/590
6. The shaded points are certified in accordance with ARI Standard 550/590-98

MODEL: YLAA0100SE									IPLV= 14.3
AIR TEMPERATURE ON - CONDENSER (°F)									
LCWT (°F)	105.0			110.0			115.0		
	TONS	KW	EER	TONS	KW	EER	TONS	KW	EER
40.0	82.8	120.7	7.7	79.2	127.2	7.0	75.5	133.9	6.4
42.0	85.6	121.7	7.9	81.8	128.2	7.2	78.1	134.9	6.5
44.0	88.4	122.7	8.1	84.5	129.2	7.4	80.7	135.9	6.7
45.0	89.8	123.2	8.2	85.9	129.7	7.5	62.0	91.9	7.4
46.0	91.2	123.7	8.3	87.3	130.2	7.6	53.3	70.2	8.1
48.0	94.1	124.8	8.5	90.1	131.3	7.7	55.2	70.6	8.4
50.0	97.0	125.9	8.7	92.9	132.4	7.9	57.1	71.1	8.6

MODEL: YLAA0101HE									IPLV= 15.4
AIR TEMPERATURE ON - CONDENSER (°F)									
LCWT (°F)	105.0			110.0			115.0		
	TONS	KW	EER	TONS	KW	EER	TONS	KW	EER
40.0	85.3	115.9	8.1	81.7	122.1	7.4	68.9	106.7	7.1
42.0	88.1	116.8	8.3	84.4	123.0	7.6	71.3	107.3	7.3
44.0	91.1	117.7	8.6	87.2	123.9	7.8	73.8	108.1	7.5
45.0	92.5	118.1	8.7	88.6	124.4	7.9	75.1	108.4	7.6
46.0	94.0	118.6	8.8	90.1	124.9	8.0	76.3	108.8	7.7
48.0	97.0	119.6	9.0	93.0	125.8	8.2	78.9	109.5	7.9
50.0	100.1	120.6	9.2	95.9	126.9	8.4	58.3	69.4	8.8

MODEL: YLAA0115SE									IPLV= 14.6
AIR TEMPERATURE ON - CONDENSER (°F)									
LCWT (°F)	105.0			110.0			115.0		
	TONS	KW	EER	TONS	KW	EER	TONS	KW	EER
40.0	98.6	142.2	7.8	94.3	149.5	7.1	89.9	157.2	6.4
42.0	101.8	143.5	8.0	97.4	150.8	7.3	92.9	158.4	6.6
44.0	105.1	144.8	8.1	100.6	152.1	7.4	95.9	159.7	6.8
45.0	106.8	145.4	8.2	102.2	152.7	7.5	56.5	71.0	8.4
46.0	108.5	146.1	8.3	103.8	153.4	7.6	57.5	71.3	8.5
48.0	111.8	147.4	8.5	107.0	154.7	7.8	59.5	71.7	8.7
50.0	115.2	148.8	8.7	110.3	156.1	8.0	61.6	72.2	9.0

MODEL: YLAA0120SE									IPLV= 14.8
AIR TEMPERATURE ON - CONDENSER (°F)									
LCWT (°F)	105.0			110.0			115.0		
	TONS	KW	EER	TONS	KW	EER	TONS	KW	EER
40.0	103.3	144.0	8.0	98.6	151.2	7.3	93.8	158.8	6.7
42.0	106.7	145.4	8.2	101.9	152.6	7.5	54.8	70.6	8.1
44.0	110.2	146.7	8.4	105.3	154.0	7.7	56.8	71.1	8.4
45.0	111.9	147.4	8.5	107.0	154.7	7.8	57.8	71.3	8.5
46.0	113.7	148.1	8.6	108.6	155.4	7.9	58.8	71.6	8.6
48.0	117.2	149.6	8.8	112.1	156.9	8.1	60.9	72.1	8.9
50.0	120.8	151.1	9.0	115.5	158.4	8.2	63.0	72.6	9.1

NOTES:

1. kW = Compressor Input Power
2. EER = Chiller EER (includes power from compressors, fans, and the control panels 0.8 kW)
3. LCWT = Leaving Chilled Water Temperature
4. Ratings are based upon 2.4 GPM evaporator water per ton and 0.0001 fouling factor
5. Rated in accordance with ARI Standard 550/590
6. The shaded points are certified in accordance with ARI Standard 550/590-98

Ratings - 60 Hz - continued

MODEL: YLAA0125HE IPLV= 14.9

AIR TEMPERATURE ON - CONDENSER (°F)																		
LCWT (°F)	75.0			80.0			85.0			90.0			95.0			100.0		
	TONS	KW	EER	TONS	KW	EER	TONS	KW	EER	TONS	KW	EER	TONS	KW	EER	TONS	KW	EER
40.0	122.3	96.0	13.4	119.3	101.1	12.5	116.2	106.6	11.6	113.0	112.4	10.8	109.6	118.7	10.0	105.5	125.0	9.2
42.0	126.4	96.9	13.7	123.2	102.0	12.8	120.0	107.5	11.9	116.7	113.4	11.0	113.3	119.6	10.2	109.1	125.9	9.4
44.0	130.5	97.9	14.1	127.3	103.0	13.1	123.9	108.5	12.2	120.5	114.3	11.3	117.0	120.6	10.5	112.7	126.9	9.6
45.0	132.6	98.3	14.2	129.3	103.5	13.3	125.9	108.9	12.3	122.4	114.8	11.5	118.8	121.1	10.6	114.5	127.4	9.8
46.0	134.7	98.8	14.4	131.3	104.0	13.4	127.9	109.4	12.5	124.4	115.3	11.6	120.7	121.6	10.7	116.3	127.9	9.9
48.0	138.9	99.8	14.7	135.5	105.0	13.7	132.0	110.5	12.8	128.3	116.4	11.9	124.6	122.7	11.0	120.0	129.0	10.1
50.0	143.2	100.9	15.0	139.7	106.0	14.0	136.1	111.5	13.1	132.3	117.4	12.1	128.4	123.8	11.2	123.8	130.1	10.4

MODEL: YLAA0135SE IPLV= 15.4

AIR TEMPERATURE ON - CONDENSER (°F)																		
LCWT (°F)	75.0			80.0			85.0			90.0			95.0			100.0		
	TONS	KW	EER	TONS	KW	EER	TONS	KW	EER	TONS	KW	EER	TONS	KW	EER	TONS	KW	EER
40.0	133.9	112.1	12.8	130.4	118.1	11.9	126.8	124.4	11.0	123.1	131.3	10.2	119.3	138.6	9.4	114.8	145.7	8.7
42.0	138.2	113.3	13.1	134.6	119.3	12.2	131.0	125.6	11.3	127.2	132.5	10.5	123.2	139.8	9.7	118.6	147.0	8.9
44.0	142.7	114.5	13.4	139.0	120.5	12.5	135.2	126.9	11.6	131.3	133.8	10.7	127.3	141.1	9.9	122.5	148.2	9.1
45.0	144.9	115.1	13.5	141.2	121.1	12.6	137.3	127.5	11.7	133.4	134.4	10.8	129.3	141.7	10.0	124.4	148.9	9.2
46.0	147.2	115.8	13.7	143.4	121.8	12.7	139.5	128.2	11.8	135.5	135.1	10.9	131.3	142.3	10.1	126.4	149.6	9.3
48.0	151.8	117.1	14.0	147.8	123.1	13.0	143.9	129.5	12.1	139.7	136.4	11.2	135.5	143.7	10.3	130.4	150.9	9.5
50.0	156.4	118.4	14.2	152.4	124.5	13.3	148.2	131.0	12.3	144.0	137.8	11.4	139.7	145.1	10.6	134.4	152.3	9.7

MODEL: YLAA0141HE IPLV= 14.4

AIR TEMPERATURE ON - CONDENSER (°F)																		
LCWT (°F)	75.0			80.0			85.0			90.0			95.0			100.0		
	TONS	KW	EER	TONS	KW	EER	TONS	KW	EER	TONS	KW	EER	TONS	KW	EER	TONS	KW	EER
40.0	137.9	110.7	13.3	134.3	116.5	12.4	130.5	122.7	11.5	126.8	129.3	10.7	122.8	136.5	9.8	118.0	143.7	9.0
42.0	142.4	111.8	13.6	138.7	117.6	12.7	134.9	123.9	11.8	130.9	130.6	10.9	126.9	137.7	10.1	122.0	144.9	9.2
44.0	147.0	113.0	14.0	143.2	118.9	13.0	139.3	125.1	12.1	135.2	131.9	11.2	131.1	139.0	10.3	126.1	146.1	9.5
45.0	148.3	113.4	14.0	145.5	119.5	13.1	141.5	125.8	12.2	137.4	132.5	11.3	133.2	139.6	10.4	128.1	146.8	9.6
46.0	151.7	114.3	14.3	146.9	119.9	13.2	143.8	126.4	12.3	139.6	133.2	11.4	135.3	140.3	10.6	130.2	147.4	9.7
48.0	156.5	115.6	14.6	152.4	121.4	13.6	148.1	127.7	12.6	144.0	134.5	11.7	139.6	141.6	10.8	134.3	148.8	9.9
50.0	161.2	116.9	14.8	157.1	122.8	13.8	152.9	129.1	12.9	148.5	135.9	11.9	144.0	143.0	11.0	138.5	150.1	10.2

MODEL: YLAA0150SE IPLV= 15.2

AIR TEMPERATURE ON - CONDENSER (°F)																		
LCWT (°F)	75.0			80.0			85.0			90.0			95.0			100.0		
	TONS	KW	EER	TONS	KW	EER	TONS	KW	EER	TONS	KW	EER	TONS	KW	EER	TONS	KW	EER
40.0	147.8	128.1	12.5	144.0	135.0	11.6	140.0	142.3	10.8	135.9	150.1	10.0	131.7	158.4	9.2	126.7	166.5	8.4
42.0	152.6	129.5	12.8	148.6	136.4	11.9	144.6	143.7	11.0	140.3	151.5	10.2	136.0	159.8	9.4	130.8	168.0	8.7
44.0	157.4	130.9	13.1	153.3	137.8	12.2	149.2	145.1	11.3	144.8	153.0	10.4	140.4	161.3	9.6	135.0	169.5	8.9
45.0	159.9	131.6	13.2	155.7	138.5	12.3	151.5	145.9	11.4	147.1	153.7	10.6	142.6	162.0	9.7	137.2	170.3	9.0
46.0	162.4	132.3	13.4	158.1	139.3	12.4	153.8	146.6	11.5	149.4	154.5	10.7	144.8	162.8	9.9	139.3	171.1	9.1
48.0	167.3	133.8	13.6	163.0	140.8	12.7	158.5	148.2	11.8	154.0	156.0	10.9	149.2	164.4	10.1	143.6	172.6	9.3
50.0	172.4	135.4	13.9	167.9	142.4	12.9	163.3	149.8	12.0	158.6	157.7	11.1	153.8	166.0	10.3	148.0	174.3	9.5

NOTES:

1. kW = Compressor Input Power
2. EER = Chiller EER (includes power from compressors, fans, and the control panels 0.8 kW)
3. LCWT = Leaving Chilled Water Temperature
4. Ratings are based upon 2.4 GPM evaporator water per ton and 0.0001 fouling factor
5. Rated in accordance with ARI Standard 550/590
6. The shaded points are certified in accordance with ARI Standard 550/590-98

MODEL: YLAA0125HE									IPLV= 14.9
AIR TEMPERATURE ON - CONDENSER (°F)									
LCWT (°F)	105.0			110.0			115.0		
	TONS	KW	EER	TONS	KW	EER	TONS	KW	EER
40.0	101.5	131.5	8.4	97.2	138.4	7.7	92.9	145.7	7.0
42.0	104.9	132.5	8.6	100.5	139.4	7.9	96.1	146.7	7.2
44.0	108.3	133.5	8.8	103.9	140.4	8.1	99.3	147.7	7.4
45.0	110.1	134.0	9.0	105.6	140.9	8.2	100.9	148.2	7.5
46.0	111.9	134.5	9.1	107.3	141.4	8.3	102.6	148.7	7.6
48.0	115.4	135.6	9.3	110.7	142.5	8.5	105.9	149.8	7.8
50.0	119.1	136.6	9.5	114.2	143.6	8.7	109.3	150.9	8.0

MODEL: YLAA0135SE									IPLV= 15.4
AIR TEMPERATURE ON - CONDENSER (°F)									
LCWT (°F)	105.0			110.0			115.0		
	TONS	KW	EER	TONS	KW	EER	TONS	KW	EER
40.0	110.1	153.3	7.9	105.3	161.3	7.2	84.3	124.1	7.4
42.0	113.8	154.6	8.1	108.9	162.6	7.4	87.3	125.0	7.6
44.0	117.5	155.9	8.3	112.5	163.9	7.6	90.3	125.8	7.8
45.0	119.4	156.5	8.4	114.3	164.5	7.7	91.8	126.2	7.9
46.0	121.3	157.2	8.5	116.2	165.2	7.8	93.4	126.6	8.0
48.0	125.2	158.6	8.7	119.9	166.6	8.0	96.5	127.5	8.2
50.0	129.1	160.0	8.9	123.6	168.0	8.2	99.6	128.4	8.4

MODEL: YLAA0141HE									IPLV= 14.4
AIR TEMPERATURE ON - CONDENSER (°F)									
LCWT (°F)	105.0			110.0			115.0		
	TONS	KW	EER	TONS	KW	EER	TONS	KW	EER
40.0	113.2	151.1	8.3	108.3	159.0	7.5	103.3	167.2	6.9
42.0	117.1	152.3	8.5	112.0	160.2	7.7	106.9	168.5	7.1
44.0	121.0	153.6	8.7	115.8	161.5	7.9	110.5	169.8	7.2
45.0	123.0	154.3	8.8	117.7	162.1	8.0	112.3	170.4	7.3
46.0	125.0	154.9	8.9	119.6	162.8	8.1	114.2	171.1	7.4
48.0	129.0	156.3	9.1	123.5	164.1	8.3	97.7	127.4	8.3
50.0	133.0	157.6	9.3	127.4	165.5	8.5	100.9	128.3	8.5

MODEL: YLAA0150SE									IPLV= 15.2
AIR TEMPERATURE ON - CONDENSER (°F)									
LCWT (°F)	105.0			110.0			115.0		
	TONS	KW	EER	TONS	KW	EER	TONS	KW	EER
40.0	121.5	175.2	7.7	116.2	184.2	7.1	94.6	147.5	7.1
42.0	125.5	176.6	7.9	120.1	185.7	7.2	97.9	148.5	7.3
44.0	129.6	178.1	8.1	124.0	187.2	7.4	101.2	149.6	7.4
45.0	131.6	178.9	8.2	126.0	188.0	7.5	102.8	150.1	7.5
46.0	133.7	179.7	8.3	128.0	188.8	7.6	104.5	150.7	7.6
48.0	137.9	181.3	8.5	132.0	190.4	7.8	107.9	151.8	7.8
50.0	142.1	182.9	8.7	136.1	192.0	7.9	111.4	153.0	8.0

NOTES:

1. kW = Compressor Input Power
2. EER = Chiller EER (includes power from compressors, fans, and the control panels 0.8 kW)
3. LCWT = Leaving Chilled Water Temperature
4. Ratings are based upon 2.4 GPM evaporator water per ton and 0.0001 fouling factor
5. Rated in accordance with ARI Standard 550/590
6. The shaded points are certified in accordance with ARI Standard 550/590-98

Ratings - 60 Hz - continued

MODEL: YLAA0155SE IPLV= 15.1

AIR TEMPERATURE ON - CONDENSER (°F)																		
LCWT (°F)	75.0			80.0			85.0			90.0			95.0			100.0		
	TONS	KW	EER	TONS	KW	EER	TONS	KW	EER	TONS	KW	EER	TONS	KW	EER	TONS	KW	EER
40.0	151.2	129.4	12.7	147.2	136.2	11.8	143.1	143.5	10.9	138.8	151.3	10.1	134.4	159.5	9.3	129.2	167.7	8.6
42.0	156.1	130.8	13.0	152.0	137.7	12.1	147.7	144.9	11.2	143.3	152.8	10.3	138.8	161.0	9.5	133.4	169.2	8.8
44.0	161.1	132.3	13.3	156.8	139.2	12.3	152.5	146.5	11.4	147.9	154.3	10.6	143.3	162.5	9.8	137.7	170.8	9.0
45.0	163.6	133.0	13.4	159.3	139.9	12.5	154.8	147.2	11.6	150.2	155.1	10.7	145.5	163.3	9.9	139.9	171.5	9.1
46.0	166.1	133.8	13.5	161.7	140.7	12.6	157.2	148.0	11.7	152.6	155.9	10.8	147.8	164.1	10.0	142.1	172.4	9.2
48.0	171.2	135.3	13.8	166.7	142.3	12.8	162.0	149.7	11.9	157.3	157.5	11.0	152.4	165.8	10.2	146.4	174.0	9.4
50.0	172.7	136.0	13.9	171.7	143.9	13.1	166.9	151.4	12.2	162.0	159.2	11.3	157.0	167.5	10.4	151.0	175.7	9.6

MODEL: YLAA0156HE IPLV= 15.5

AIR TEMPERATURE ON - CONDENSER (°F)																		
LCWT (°F)	75.0			80.0			85.0			90.0			95.0			100.0		
	TONS	KW	EER	TONS	KW	EER	TONS	KW	EER	TONS	KW	EER	TONS	KW	EER	TONS	KW	EER
40.0	152.1	119.7	13.4	148.4	126.0	12.5	144.5	132.8	11.6	140.5	140.1	10.7	136.4	147.9	9.9	131.3	155.7	9.1
42.0	157.1	120.8	13.7	153.3	127.1	12.8	149.3	134.0	11.9	145.2	141.3	11.0	140.9	149.1	10.2	135.7	156.9	9.4
44.0	162.2	122.0	14.0	158.3	128.3	13.1	154.2	135.2	12.2	149.9	142.5	11.3	145.5	150.3	10.4	140.2	158.2	9.6
45.0	164.8	122.6	14.2	160.8	129.0	13.2	156.6	135.8	12.3	152.3	143.1	11.4	147.9	151.0	10.6	142.4	158.8	9.7
46.0	167.4	123.2	14.4	163.3	129.6	13.4	159.1	136.4	12.5	154.7	143.7	11.6	150.2	151.6	10.7	144.7	159.4	9.9
48.0	172.7	124.5	14.7	168.5	130.9	13.7	164.1	137.7	12.7	159.6	145.0	11.8	155.0	152.9	11.0	149.3	160.8	10.1
50.0	178.0	125.7	15.0	173.7	132.1	14.0	169.2	139.0	13.0	164.6	146.4	12.1	159.8	154.2	11.2	154.0	162.1	10.3

MODEL: YLAA0170SE IPLV= 15.1

AIR TEMPERATURE ON - CONDENSER (°F)																		
LCWT (°F)	75.0			80.0			85.0			90.0			95.0			100.0		
	TONS	KW	EER	TONS	KW	EER	TONS	KW	EER	TONS	KW	EER	TONS	KW	EER	TONS	KW	EER
40.0	176.1	148.9	12.8	171.7	157.0	11.9	167.1	165.6	11.0	162.4	174.7	10.2	157.5	184.5	9.4	151.6	194.2	8.6
42.0	181.8	150.5	13.0	177.3	158.5	12.1	172.6	167.1	11.3	167.7	176.3	10.4	162.6	186.1	9.6	156.6	195.8	8.8
44.0	187.5	152.1	13.3	182.9	160.0	12.4	178.1	168.7	11.5	173.0	177.9	10.7	167.8	187.7	9.8	161.6	197.5	9.1
45.0	190.5	152.9	13.5	185.8	160.8	12.6	180.9	169.5	11.6	175.8	178.7	10.8	170.5	188.6	10.0	164.2	198.3	9.2
46.0	193.4	153.7	13.6	188.7	161.7	12.7	183.7	170.3	11.8	178.5	179.6	10.9	173.1	189.4	10.1	166.7	199.2	9.3
48.0	199.3	155.3	13.9	194.5	163.3	13.0	189.3	172.0	12.0	184.0	181.3	11.1	178.5	191.2	10.3	172.0	200.9	9.5
50.0	205.4	157.0	14.2	200.4	165.0	13.2	195.1	173.7	12.3	189.6	183.1	11.4	184.0	192.9	10.5	177.2	202.7	9.7

MODEL: YLAA0175HE IPLV= 15.1

AIR TEMPERATURE ON - CONDENSER (°F)																		
LCWT (°F)	75.0			80.0			85.0			90.0			95.0			100.0		
	TONS	KW	EER	TONS	KW	EER	TONS	KW	EER	TONS	KW	EER	TONS	KW	EER	TONS	KW	EER
40.0	183.4	151.1	13.1	178.7	159.1	12.2	173.8	167.6	11.3	168.7	176.8	10.5	163.4	186.5	9.6	157.1	196.1	8.9
42.0	189.4	152.8	13.4	184.6	160.7	12.5	179.5	169.3	11.6	174.2	178.5	10.7	168.8	188.2	9.9	162.3	197.9	9.1
44.0	195.5	154.5	13.7	190.5	162.4	12.8	185.3	171.0	11.8	179.8	180.2	11.0	174.2	190.0	10.1	167.6	199.6	9.3
45.0	198.6	155.4	13.8	193.5	163.2	12.9	188.2	171.9	12.0	182.7	181.1	11.1	177.0	190.9	10.2	170.3	200.5	9.4
46.0	201.7	156.2	14.0	196.5	164.1	13.0	191.1	172.8	12.1	185.5	182.0	11.2	179.8	191.8	10.3	173.0	201.4	9.5
48.0	208.0	158.0	14.3	202.7	165.9	13.3	197.1	174.6	12.4	191.3	183.8	11.4	185.4	193.6	10.6	178.4	203.3	9.7
50.0	214.4	159.8	14.6	208.8	167.9	13.6	203.1	176.5	12.6	197.2	185.7	11.7	191.1	195.5	10.8	183.9	205.2	9.9

NOTES:

1. kW = Compressor Input Power
2. EER = Chiller EER (includes power from compressors, fans, and the control panels 0.8 kW)
3. LCWT = Leaving Chilled Water Temperature
4. Ratings are based upon 2.4 GPM evaporator water per ton and 0.0001 fouling factor
5. Rated in accordance with ARI Standard 550/590
6. The shaded points are certified in accordance with ARI Standard 550/590-98

MODEL: YLAA0155SE									IPLV= 15.1
AIR TEMPERATURE ON - CONDENSER (°F)									
LCWT (°F)	105.0			110.0			115.0		
	TONS	KW	EER	TONS	KW	EER	TONS	KW	EER
40.0	123.8	176.2	7.8	118.3	185.2	7.1	95.7	148.0	7.1
42.0	127.9	177.8	8.0	122.3	186.8	7.3	99.1	149.1	7.3
44.0	132.1	179.3	8.2	126.3	188.4	7.5	102.5	150.2	7.5
45.0	134.2	180.1	8.3	128.4	189.2	7.6	104.2	150.8	7.6
46.0	136.3	181.0	8.4	130.4	190.0	7.7	105.9	151.3	7.7
48.0	140.6	182.6	8.6	134.5	191.7	7.9	109.4	152.5	7.9
50.0	144.9	184.4	8.8	118.2	146.4	8.9	112.9	153.7	8.1

MODEL: YLAA0156HE									IPLV= 15.5
AIR TEMPERATURE ON - CONDENSER (°F)									
LCWT (°F)	105.0			110.0			115.0		
	TONS	KW	EER	TONS	KW	EER	TONS	KW	EER
40.0	126.2	164.0	8.4	121.0	172.6	7.7	115.6	181.6	7.0
42.0	130.5	165.2	8.6	125.1	173.8	7.9	119.6	182.9	7.2
44.0	134.8	166.4	8.8	129.3	175.0	8.1	123.6	184.1	7.4
45.0	137.0	167.0	8.9	131.4	175.7	8.2	125.6	184.8	7.5
46.0	139.2	167.7	9.1	133.5	176.3	8.3	127.7	185.4	7.6
48.0	143.6	169.0	9.3	137.8	177.7	8.5	131.8	186.8	7.8
50.0	148.1	170.3	9.5	142.1	179.0	8.7	136.0	188.2	8.0

MODEL: YLAA0170SE									IPLV= 15.1
AIR TEMPERATURE ON - CONDENSER (°F)									
LCWT (°F)	105.0			110.0			115.0		
	TONS	KW	EER	TONS	KW	EER	TONS	KW	EER
40.0	145.6	204.3	7.9	139.4	215.0	7.2	133.1	226.2	6.6
42.0	150.4	206.0	8.1	144.1	216.7	7.4	137.6	227.9	6.7
44.0	155.3	207.6	8.3	148.8	218.3	7.6	142.1	229.6	6.9
45.0	157.7	208.5	8.4	151.2	219.2	7.7	144.4	230.4	7.0
46.0	160.2	209.3	8.5	153.5	220.1	7.8	146.7	231.3	7.1
48.0	165.2	211.1	8.7	158.4	221.8	8.0	151.4	233.1	7.3
50.0	170.3	212.9	8.9	163.3	223.7	8.1	156.1	234.9	7.4

MODEL: YLAA0175HE									IPLV= 15.1
AIR TEMPERATURE ON - CONDENSER (°F)									
LCWT (°F)	105.0			110.0			115.0		
	TONS	KW	EER	TONS	KW	EER	TONS	KW	EER
40.0	150.7	206.2	8.1	144.1	216.8	7.4	137.4	227.9	6.7
42.0	155.7	207.9	8.3	149.0	218.6	7.6	142.1	229.7	6.9
44.0	160.8	209.7	8.5	153.9	220.4	7.8	146.8	231.5	7.1
45.0	163.4	210.6	8.6	156.4	221.3	7.9	149.2	232.4	7.2
46.0	166.0	211.5	8.7	158.9	222.2	8.0	151.6	233.4	7.3
48.0	171.3	213.4	8.9	163.9	224.1	8.2	156.4	235.3	7.4
50.0	176.6	215.4	9.1	169.0	226.1	8.4	161.4	237.2	7.6

NOTES:

1. kW = Compressor Input Power
2. EER = Chiller EER (includes power from compressors, fans, and the control panels 0.8 kW)
3. LCWT = Leaving Chilled Water Temperature
4. Ratings are based upon 2.4 GPM evaporator water per ton and 0.0001 fouling factor
5. Rated in accordance with ARI Standard 550/590
6. The shaded points are certified in accordance with ARI Standard 550/590-98

Part Load Ratings - Standard Efficiency

YLAA0070SE				
% DISPL	AMBIENT °F	TONS	COMP KW	EER
100.0	95.0	71.8	78.1	10.2
83.3	88.4	63.8	59.9	11.5
66.7	81.1	55.2	42.2	13.5
50.0	71.1	43.1	28.2	15.6
33.3	60.3	30.2	16.5	18.3
16.7	55.0	15.1	7.7	19.3

IPLV: 15.9 EER

YLAA0080SE				
% DISPL	AMBIENT °F	TONS	COMP KW	EER
100.0	95.0	77.7	87.7	9.9
83.6	88.5	69.2	68.4	11.0
66.7	80.5	59.2	46.4	13.4
50.3	71.1	46.7	31.9	15.2
33.3	59.5	31.7	18.3	17.5
16.9	55.0	16.7	9.7	17.7

IPLV: 15.3 EER

YLAA0090SE				
% DISPL	AMBIENT °F	TONS	COMP KW	EER
100.0	95.0	85.8	97.3	9.9
83.6	88.1	76.0	72.5	11.5
49.3	69.3	49.1	31.7	16.0
32.8	59.8	35.5	19.8	18.4
16.4	55.0	16.7	9.3	18.3

IPLV: 15.6 EER

YLAA0100SE				
% DISPL	AMBIENT °F	TONS	COMP KW	EER
100.0	98.0	95.8	110.7	9.6
86.1	89.1	86.4	86.9	10.9
57.0	75.6	64.8	45.6	14.4
43.0	65.1	48.0	34.6	14.5
13.9	55.0	16.0	9.1	17.8

IPLV: 14.3 EER

YLAA0115SE				
% DISPL	AMBIENT °F	TONS	COMP KW	EER
100.0	95.0	113.9	131.1	9.7
75.0	84.3	93.6	83.9	12.0
50.0	72.0	70.2	45.2	15.3
25.0	55.0	33.3	22.8	16.3

IPLV: 14.6 EER

YLAA0120SE				
% DISPL	AMBIENT °F	TONS	COMP KW	EER
100.0	95.0	119.7	133.2	10.0
75.0	83.9	97.6	84.7	12.4
50.0	70.8	71.5	44.8	15.6
25.0	55.0	33.4	22.9	16.3

IPLV: 14.8 EER

YLAA0135SE				
% DISPL	AMBIENT °F	TONS	COMP KW	EER
100.0	95.0	127.3	141.1	9.9
75.0	81.3	98.2	75.7	32.2
50.0	67.8	69.5	44.4	16.3
25.0	55.0	35.0	19.5	18.4

IPLV: 15.5 EER

YLAA0150SE				
% DISPL	AMBIENT °F	TONS	COMP KW	EER
100.0	95.0	140.4	161.3	9.6
80.0	87.7	123.2	112.7	11.7
60.0	77.1	98.6	73.0	13.7
40.0	64.5	69.0	43.3	16.6
20.0	55.0	34.7	19.7	18.1

IPLV: 15.2 EER

YLAA0155SE				
% DISPL	AMBIENT °F	TONS	COMP KW	EER
100.0	95.0	143.3	162.5	9.8
80.0	87.5	125.3	113.2	11.9
60.0	76.6	99.3	72.9	13.8
40.0	63.7	68.6	42.9	16.6
20.0	55.0	36.1	20.0	18.5

IPLV: 15.2 EER

YLAA0170SE				
% DISPL	AMBIENT °F	TONS	COMP KW	EER
100.0	95.0	167.8	187.7	9.8
83.3	88.4	149.3	141.2	11.3
66.7	81.2	129.1	100.0	13.3
50.0	71.3	101.4	66.9	15.2
33.3	60.8	72.1	38.8	16.6
16.7	55.0	35.6	18.6	18.0

IPLV: 15.1 EER

Part Load Ratings - High Efficiency

YLAA0091HE

% DISPL	AMBIENT °F	TONS	COMP KW	EER
100.0	95.0	88.2	88.2	10.8
83.8	88.3	78.3	67.2	12.2
50.0	70.0	51.5	31.2	14.9
16.2	55.0	16.1	8.9	18.3

IPLV: 14.9 EER

YLAA0101HE

% DISPL	AMBIENT °F	TONS	COMP KW	EER
100.0	95.0	98.5	106.1	10.2
86.1	89.4	89.2	82.3	11.6
57.0	75.3	66.1	44.3	14.6
43.0	65.7	50.5	31.5	16.6
13.9	55.0	16.1	9.0	18.1

IPLV: 15.4 EER

YLAA0125HE

% DISPL	AMBIENT °F	TONS	COMP KW	EER
100.0	95.0	117.0	120.6	10.5
75.0	83.9	95.3	77.6	12.6
50.0	70.0	68.2	45.3	15.7
25.0	55.0	33.0	22.1	16.7

IPLV: 14.9 EER

YLAA0141HE

% DISPL	AMBIENT °F	TONS	COMP KW	EER
100.0	95.0	131.1	139.0	10.3
77.7	86.3	112.0	93.0	12.6
67.0	78.3	94.5	81.7	12.6
44.7	65.4	66.5	46.2	15.6
22.3	55.0	32.3	21.8	16.5

IPLV: 14.4 EER

YLAA0156HE

% DISPL	AMBIENT °F	TONS	COMP KW	EER
100.0	95.0	145.5	150.3	10.4
80.0	87.1	126.4	106.8	12.3
60.0	75.6	98.6	72.0	14.4
40.0	64.2	70.9	41.0	16.7
20.0	55.0	34.9	19.3	18.5

IPLV: 15.5 EER

YLAA0175HE

% DISPL	AMBIENT °F	TONS	COMP KW	EER
100.0	95.0	174.2	190.0	10.1
83.3	88.2	154.4	142.4	11.6
66.7	80.6	132.5	100.3	13.6
50.0	70.4	102.9	66.7	15.4
33.3	59.6	71.5	38.3	16.6
16.7	55.0	35.1	18.6	17.8

IPLV: 15.1 EER

Physical Data - English

Refrigerant R-410A	Model Number YLAA									
	STANDARD EFFICIENCY UNITS									
	0070SE	0080SE	0090SE	0100SE	0115SE	0120SE	0135SE	0150SE	0155SE	0170SE
General Unit Data										
Nominal Tons, R-410A	71.8	77.7	85.8	95.8	113.9	119.7	127.3	140.4	143.1	167.9
Length	116.1	116.1	116.1	142.7	142.7	142.7	187.7	187.7	187.7	232.7
Width	88	88	88	88	88	88	88	88	88	88
Height	94.2	94.2	94.2	94.2	94.2	94	94.2	94.2	94.2	94.2
Number of Refrigerant Circuits	2	2	2	2	2	2	2	2	2	2
Refrigerant Charge, Operating										
R-410A, ckt1 / ckt2, lbs	51 / 50	54 / 52	57 / 57	55 / 58	62 / 58	65 / 62	81 / 71	81 / 73	83 / 76	90 / 87
Oil Charge, ckt1 / ckt2, gallons	2.58 / 2.58	3.28 / 2.58	3.28 / 2.76	3.28 / 3.33	3.33/3.33	3.33/3.33	4.99 / 2.76	4.99 / 3.33	4.99 / 3.33	4.99 / 4.99
Shipping Weight	4112	4541	4949	5407	5644	5921	6803	6958	7152	7972
Operating Weight	4450	4948	5435	5835	6072	6473	7260	7415	7705	8429
Compressors, scroll type										
Compressors per circuit	3/3	3/3	3/2	3/2	2/2	3/2	3/2	3/2	3/2	3/3
Compressors per unit	6	6	5	5	4	4	5	5	5	6
Nominal Tons per compressor										
Circuit 1	13	15	15	15	32	32	32	32	32	32
Circuit 2	13	13	15/32	32	32	32	15/32	32	32	32
Condenser										
Total Face Area ft ²	106.9	106.9	106.9	133.6	160.3	160.3	213.8	213.8	213.8	267.2
Number of Rows	1	1	1	1	1	1	1	1	1	1
Fins per Inch	20	20	20	20	20	20	20	20	20	20
Condenser Fans, Low Sound										
Number of Fans, ckt1./ckt2.	2/2	2/2	2/2	3/2	3/3	3/3	4/4	4/4	4/4	5/5
Fan hp	2	2	2	2	2	2	2	2	2	2
Fan RPM	1160	1160	1160	1160	1160	1160	1160	1160	1160	1160
Total Chiller CFM	62400	62400	62400	78000	93600	93600	124800	124800	124800	156000
Evaporator										
Water Volume, gallons	40	49	58	51	51	66	55	55	66	55
Maximum Water Side Pressure, PSIG	150	150	150	150	150	150	150	150	150	150
Maximum Refrigerant Side Pressure, PSIG	450	450	450	450	450	450	450	450	450	450
Minimum Chiller Water Flow Rate, gpm	60	100	140	100	100	150	120	120	150	120
Maximum Chiller Water Flow Rate, gpm	285	355	625	385	385	625	625	625	625	625
Water Connections Size, inches	6	6	8	6	6	8	8	8	8	8

Refrigerant R-410A	Model Number YLAA					
	HIGH EFFICIENCY UNITS					
	0091HE	0101HE	0125HE	0141HE	0156HE	0175HE
General Unit Data						
Nominal Tons, R-410A	88.1	98.3	117	130.6	145.6	174.2
Length	142.7	142.7	187.7	187.7	232.7	232.7
Width	88	88	88	88	88	88
Height	94.2	94.2	94.2	94.2	94.2	94.2
Number of Refrigerant Circuits	2	2	2	2	2	2
Refrigerant Charge, Operating						
R-410A, ckt1 / ckt2, lbs	59 / 55	55 / 71	75 / 71	83 / 73	90 / 82	94 / 92
Oil Charge, ckt1 / ckt2, gallons	2.76 / 2.76	3.28/3.33	3.33/3.33	4.99 / 2.76	4.99 / 3.33	4.99 / 4.99
Shipping Weight	5334	5569	6485	6997	7582	8313
Operating Weight	5762	5997	6913	7549	8039	8956
Compressors, scroll type						
Compressors per circuit	3/2	3/2	2/2	3/2	3/2	3/3
Compressors per unit	4	5	4	5	5	6
Nominal Tons per compressor						
Circuit 1	15/32	15	32	32	32	32
Circuit 2	15/32	32	32	15/32	32	32
Condenser						
Total Face Area ft2	160.3	160.3	213.8	213.8	267.2	267.2
Number of Rows	1	1	1	1	1	1
Fins per Inch	20	20	20	20	20	20
Condenser Fans, Low Sound						
Number of Fans, ckt1./ckt2.	3/3	4/2	4/4	4/4	4/6	5/5
Fan hp	2	2	2	2	2	2
Fan RPM	1160	1160	1160	1160	1160	1160
Total Chiller CFM	93600	93600	124800	124800	156000	156000
Evaporator						
Water Volume, gallons	51	51	51	66	55	77
Maximum Water Side Pressure, PSIG	150	150	150	150	150	150
Maximum Refrigerant Side Pressure, PSIG	450	450	450	450	450	450
Minimum Chiller Water Flow Rate, gpm	100	100	100	150	120	120
Maximum Chiller Water Flow Rate, gpm	385	385	385	625	625	625
Water Connections Size, inches	6	6	6	8	8	8

Dimensions - Four Fan Units

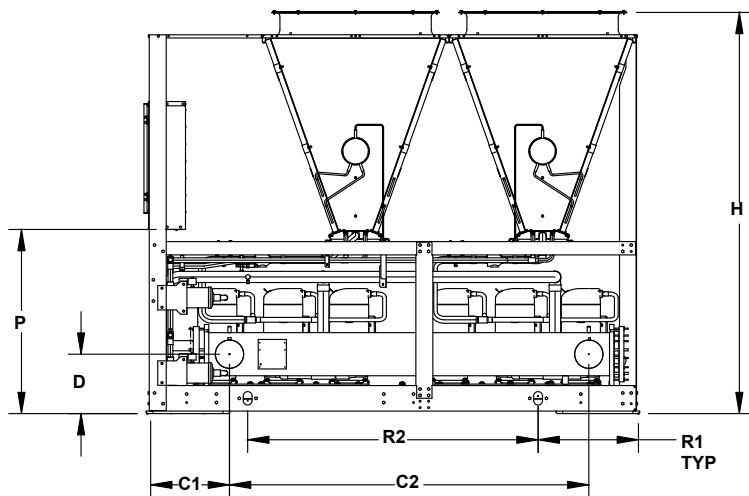
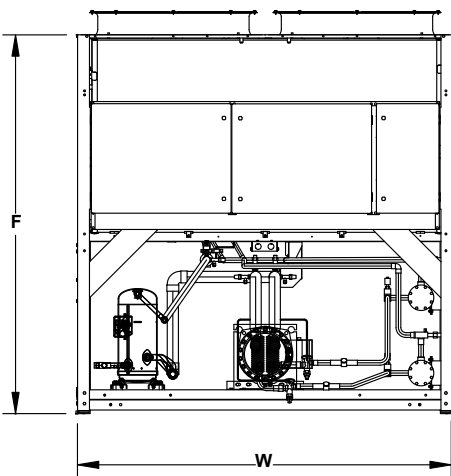
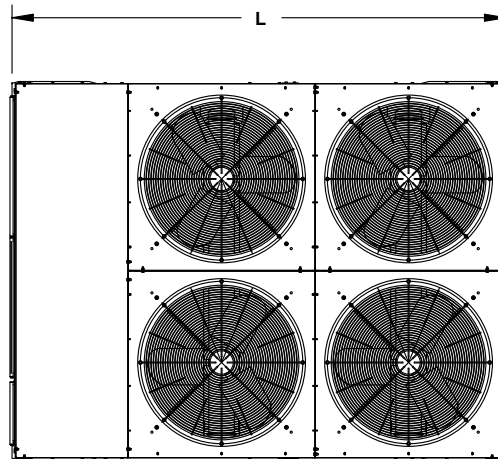

YLAA Model	L (length)	W (width)	H (height)	F	P	D	C1	C2	R4	R3	R2	R1
YLAA0070SE	116	88.3	94.2	88.5	42.8	13.4	19	84.5	NA	NA	68.3	23
YLAA0080SE	116	88.3	94.2	88.5	42.8	15	18.6	85	NA	NA	68.3	23
YLAA0090SE	116	88.3	94.2	88.5	42.8	16.3	19.6	83	NA	NA	68.3	23

NOTE:

Placement on a level surface of free of obstructions (including snow, for winter operation) or air circulation ensures rated performance, reliable operation, and ease of maintenance. Site restrictions may compromise minimum clearances indicated below, resulting in unpredictable airflow patterns and possible diminished performance. Johnson Controls's unit controls will optimize operation without nuisance high-pressure safety cutouts; however, the system designer must consider potential performance degradation. Access to the unit control center assumes the unit is no higher than on spring isolators. Recommended minimum clearances: Side to wall – 6'; rear to wall – 6'; control panel to end wall – 4'0"; top – no obstructions allowed; distance between adjacent units – 10'. No more than one adjacent wall may be higher than the unit.

Dimensions - Five Fan Units

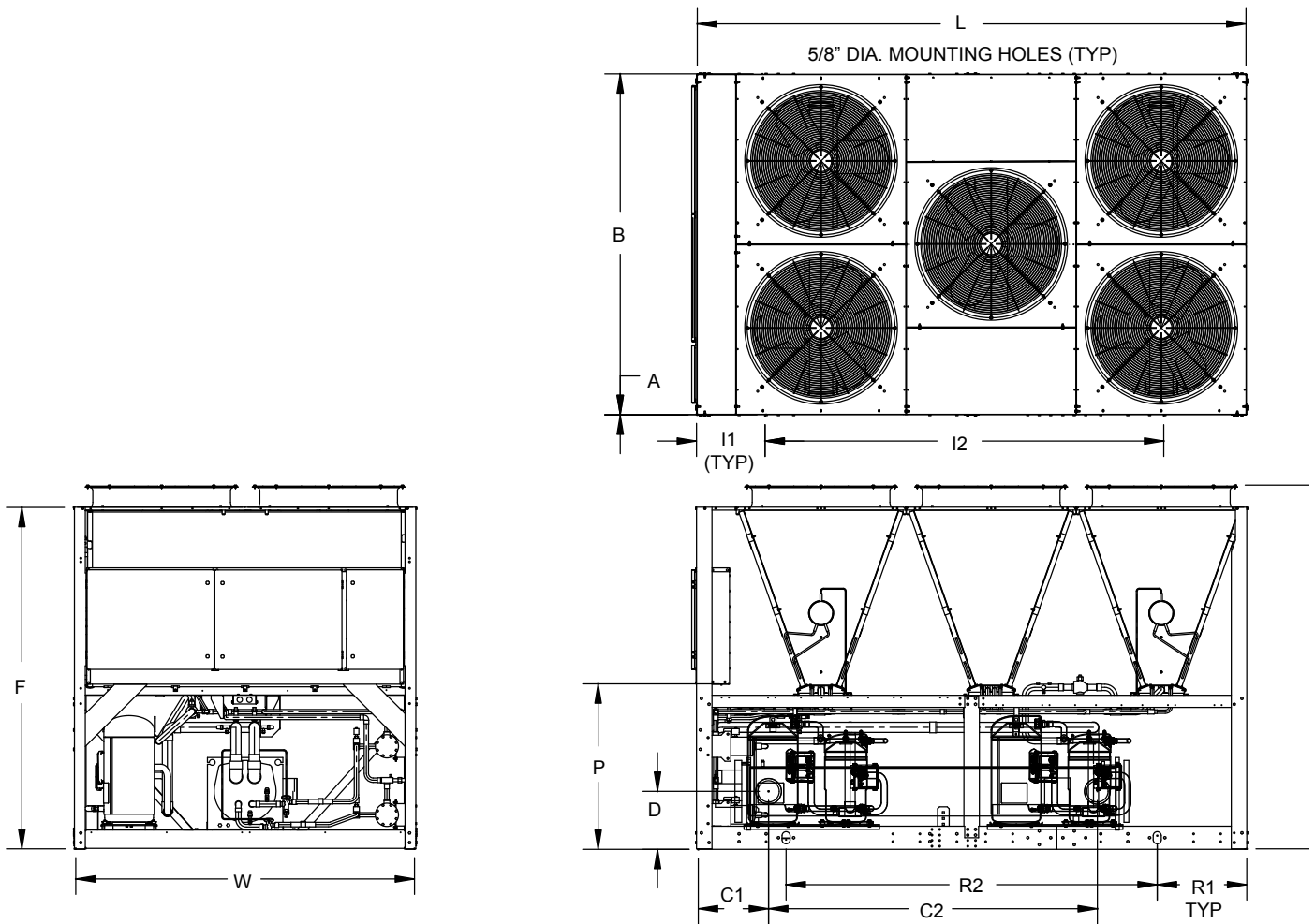

YLAA Model	L (length)	W (width)	H (height)	F	P	D	C1	C2	R4	R3	R2	R1
YLAA0100SE	143.5	88.3	94.2	88.5	42.8	15	18.6	85	NA	NA	96	23

NOTE:

Placement on a level surface of free of obstructions (including snow, for winter operation) or air circulation ensures rated performance, reliable operation, and ease of maintenance. Site restrictions may compromise minimum clearances indicated below, resulting in unpredictable airflow patterns and possible diminished performance. Johnson Controls's unit controls will optimize operation without nuisance high-pressure safety cutouts; however, the system designer must consider potential performance degradation. Access to the unit control center assumes the unit is no higher than on spring isolators. Recommended minimum clearances: Side to wall – 6'; rear to wall – 6'; control panel to end wall – 4'0"; top – no obstructions allowed; distance between adjacent units – 10'. No more than one adjacent wall may be higher than the unit.

Dimensions - Six Fan Units

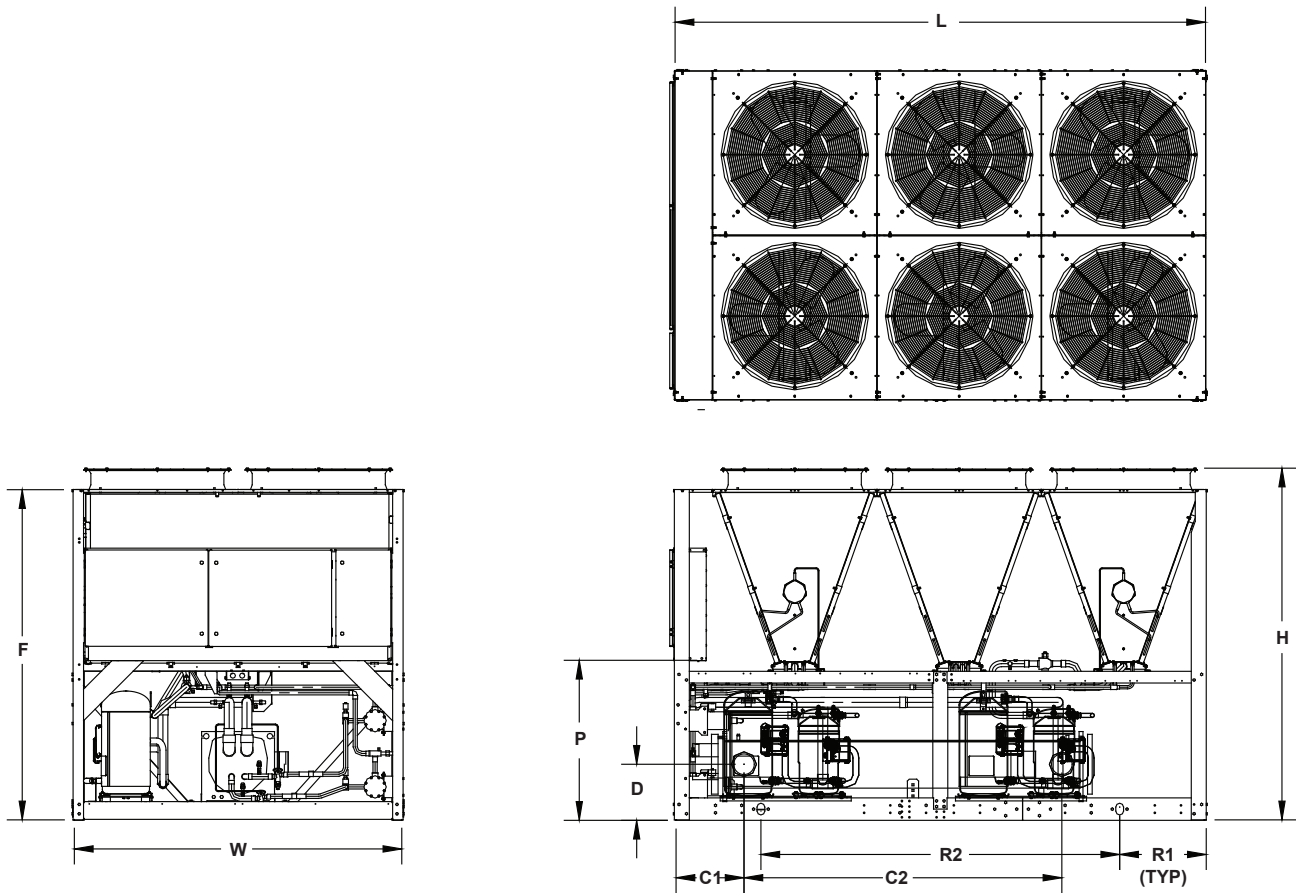

YLAA Model	L (length)	W (width)	H (height)	F	P	D	C1	C2	R4	R3	R2	R1
YLAA0091HE	143.5	88.3	94.2	88.5	42.8	15	18.6	85	NA	NA	96	23
YLAA0101HE	143.5	88.3	94.2	88.5	42.8	15	18.6	85	NA	NA	96	23
YLAA0115SE	143.5	88.3	94.2	88.5	42.8	15	18.6	85	NA	NA	96	23
YLAA0120SE	143.5	88.3	94.2	88.5	42.8	17.3	22	102	NA	NA	96	23

NOTE:

Placement on a level surface of free of obstructions (including snow, for winter operation) or air circulation ensures rated performance, reliable operation, and ease of maintenance. Site restrictions may compromise minimum clearances indicated below, resulting in unpredictable airflow patterns and possible diminished performance. Johnson Controls's unit controls will optimize operation without nuisance high-pressure safety cutouts; however, the system designer must consider potential performance degradation. Access to the unit control center assumes the unit is no higher than on spring isolators. Recommended minimum clearances: Side to wall – 6'; rear to wall – 6'; control panel to end wall – 4'0"; top – no obstructions allowed; distance between adjacent units – 10'. No more than one adjacent wall may be higher than the unit.

Dimensions - Eight Fan Units

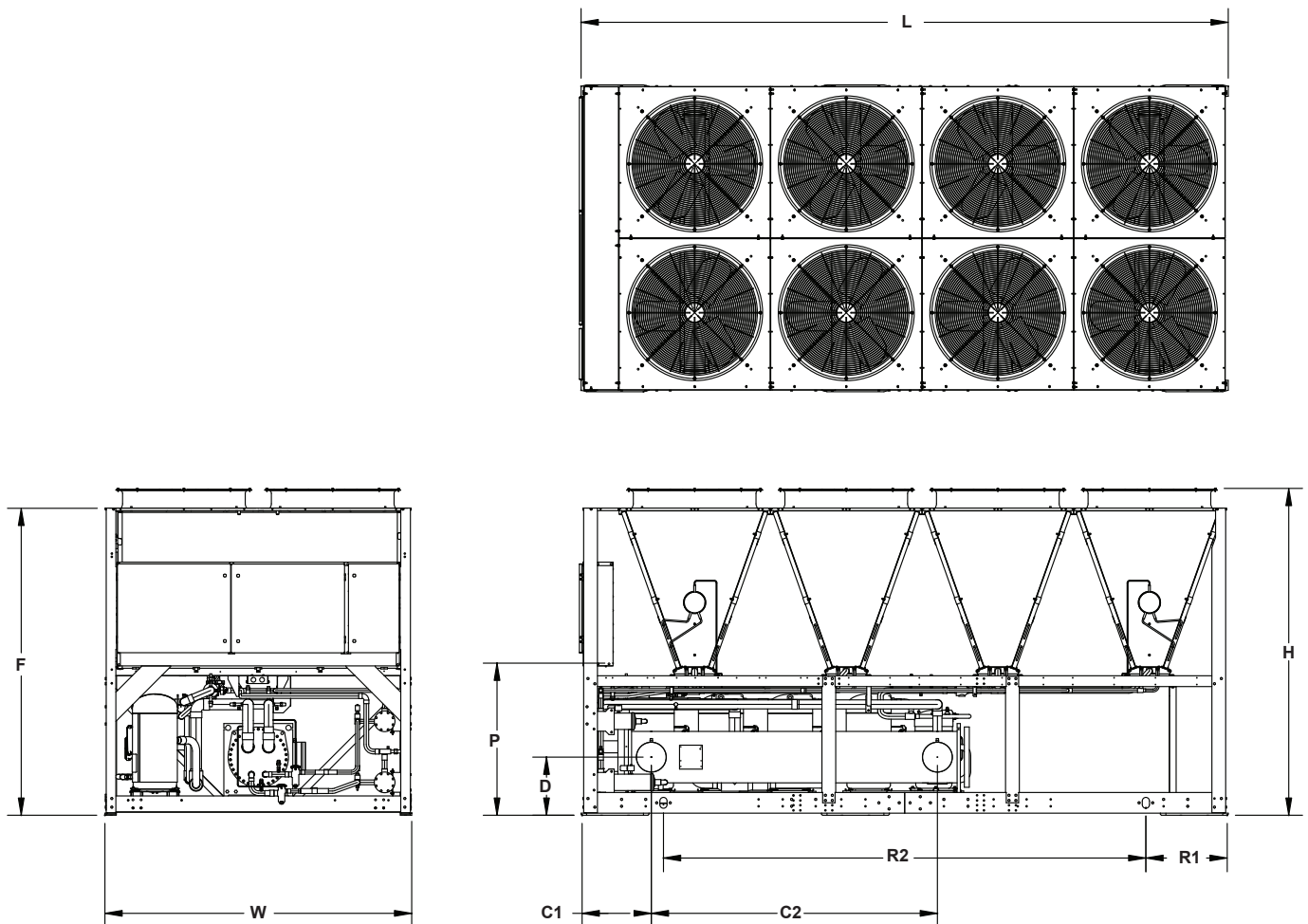

YLAA Model	L (length)	W (width)	H (height)	F	P	D	C1	C2	R4	R3	R2	R1
YLAA0125HE	187.5	88.3	94.2	88.5	42.8	15	18.6	85	NA	58	66	39
YLAA0135SE	187.5	88.3	94.2	88.5	42.8	16.3	19.6	83	NA	58	66	39
YLAA0141HE	187.5	88.3	94.2	88.5	42.8	17.3	22.1	102	NA	58	66	39
YLAA0150SE	187.5	88.3	94.2	88.5	42.8	16.3	19.6	83	NA	58	66	39
YLAA0155SE	187.5	88.3	94.2	88.5	42.8	17.3	22	102	NA	58	66	39

NOTE:

Placement on a level surface of free of obstructions (including snow, for winter operation) or air circulation ensures rated performance, reliable operation, and ease of maintenance. Site restrictions may compromise minimum clearances indicated below, resulting in unpredictable airflow patterns and possible diminished performance. Johnson Controls's unit controls will optimize operation without nuisance high-pressure safety cutouts; however, the system designer must consider potential performance degradation. Access to the unit control panel assumes the unit is no higher than on spring isolators. Recommended minimum clearances: Side to wall – 6'; rear to wall – 6'; control panel to end wall – 4'0"; top – no obstructions allowed; distance between adjacent units – 10'. No more than one adjacent wall may be higher than the unit.

Dimensions - Ten Fan Units

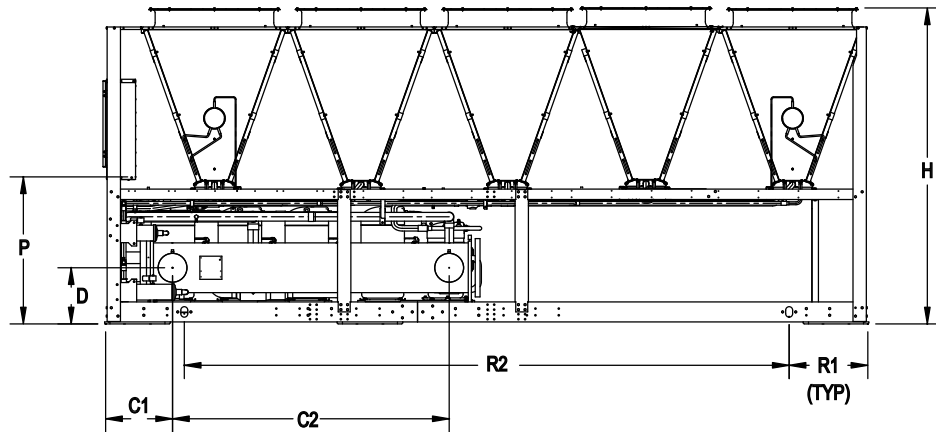
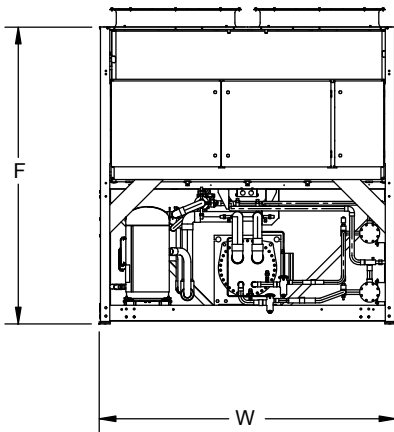
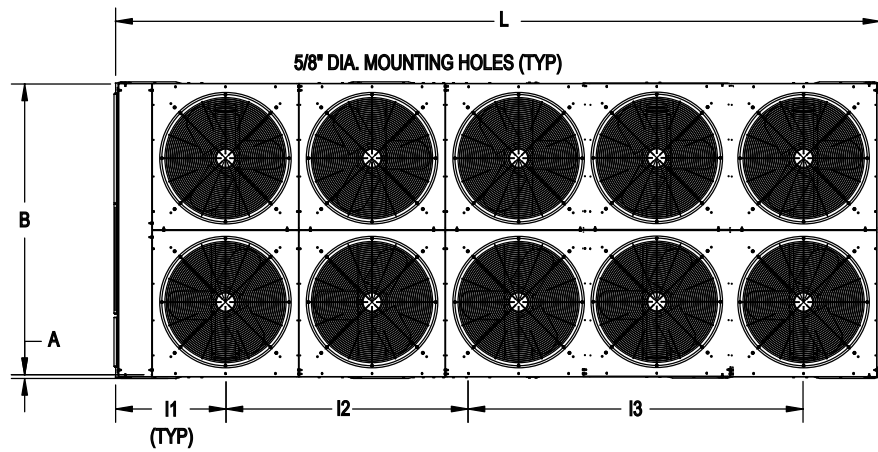

YLAA Model	L (length)	W (width)	H (height)	F	P	D	C1	C2	R4	R3	R2	R1
YLAA0156HE	232.7	88.3	94.2	88.5	42.8	16.3	19.6	83	58	43	83	23
YLAA0170SE	232.7	88.3	94.2	88.5	42.8	16.3	19.6	83	58	43	83	23
YLAA0175HE	232.7	88.3	94.2	88.5	42.8	17.3	22.1	102	58	43	83	23

Isolator Locations

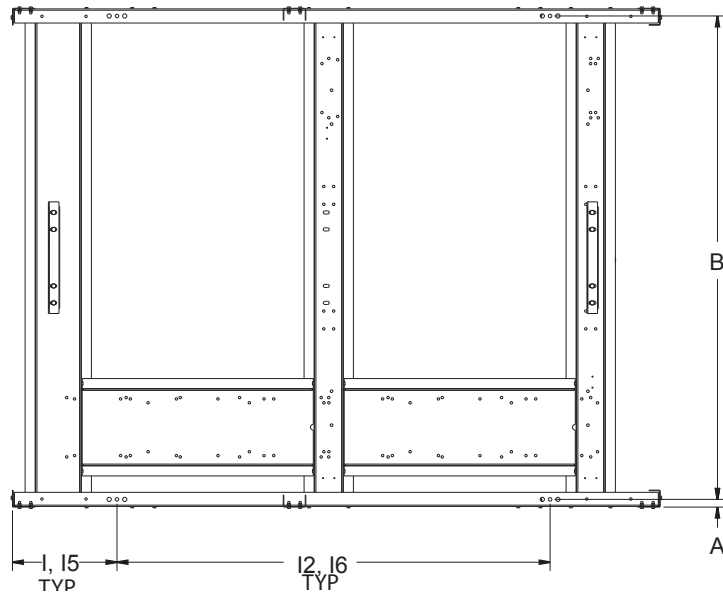

YLAA Model	AVM LOCATIONS									
	I1	I2	I3	I4	I5	I6	I7	I8	A	B
YLAA0070SE	19.5	76.6			19.5	76.6			1.4	85.5
YLAA0080SE	19.5	76.6			19.5	76.6			1.4	85.5
YLAA0090SE	19.5	76.6			19.5	76.6			1.4	85.5

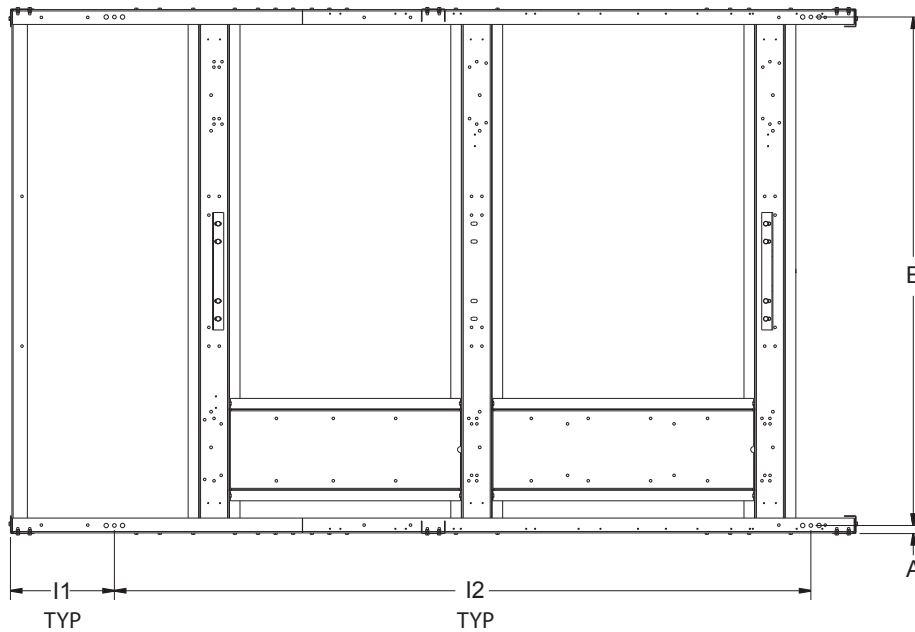

YLAA Model	AVM LOCATIONS									
	I1	I2	I3	I4	I5	I6	I7	I8	A	B
YLAA0091HE	7.6	117.2			7.6	117.2			1.4	85.5
YLAA0100SE	7.6	117.2			7.6	117.2			1.4	85.5
YLAA0101HE	7.6	117.2			7.6	117.2			1.4	85.5
YLAA0115SE	7.6	117.2			7.6	117.2			1.4	85.5
YLAA0120SE	7.6	117.2			7.6	117.2			1.4	85.5

Isolator Locations - continued

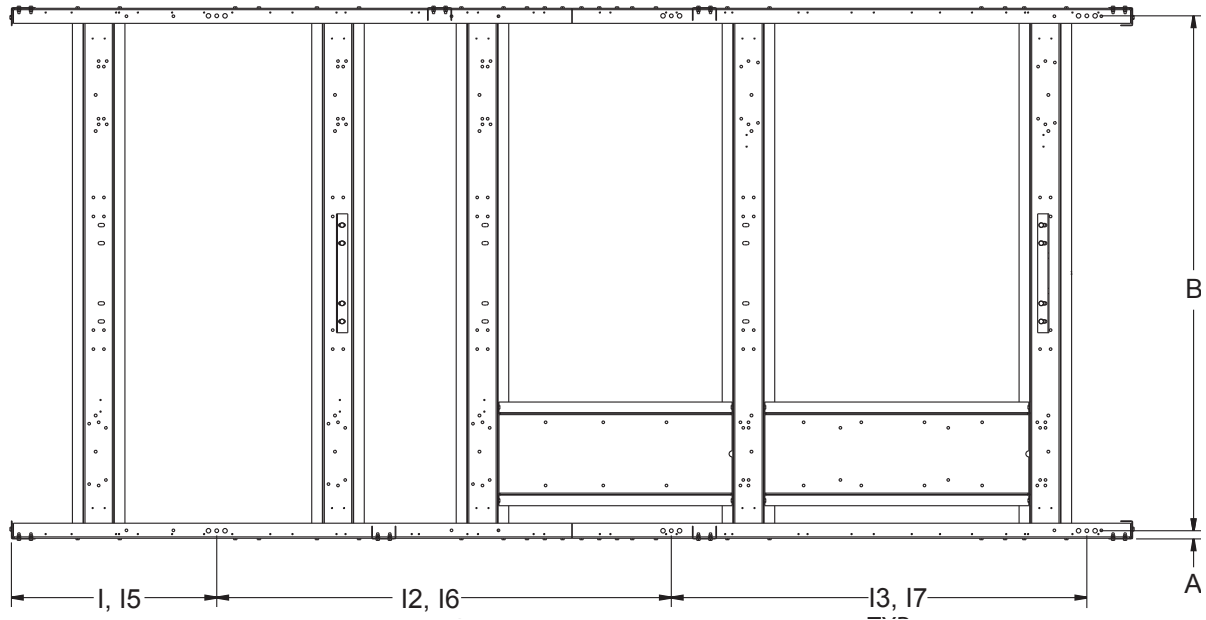

YLAA Model	AVM LOCATIONS									
	11	12	13	14	15	16	17	18	A	B
YLAA0125HE	7.6	69	80		7.6	69	80		1.4	85.5
YLAA0135SE	7.6	69	80		7.6	69	80		1.4	85.5
YLAA0141HE	7.6	69	80		7.6	69	80		1.4	85.5
YLAA0150SE	7.6	69	80		7.6	69	80		1.4	85.5
YLAA0155SE	7.6	69	80		7.6	69	80		1.4	85.5

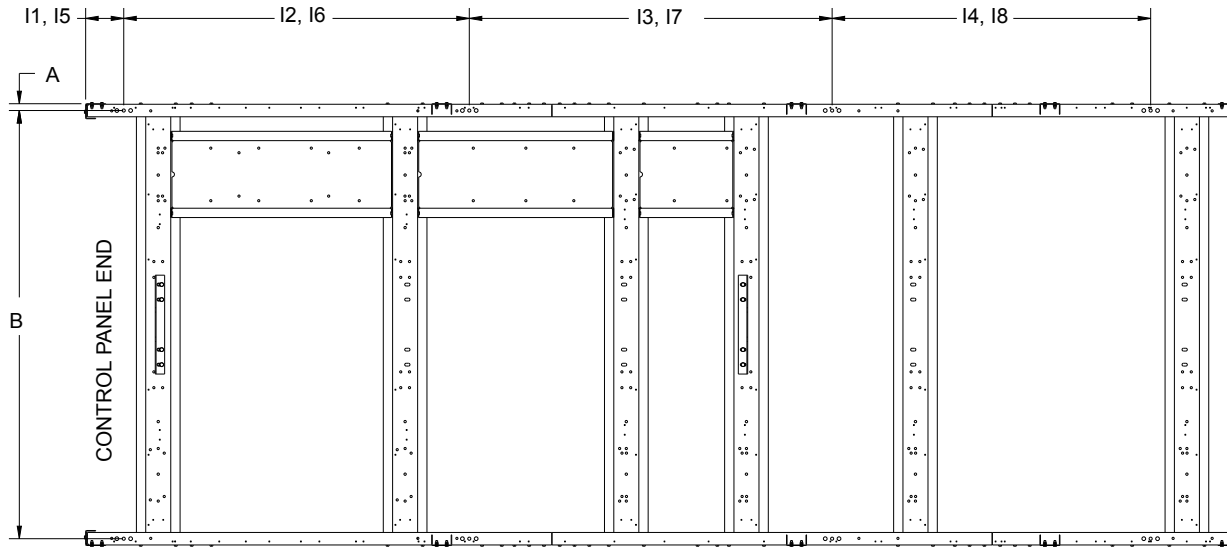

YLAA Model	AVM LOCATIONS									
	I1	I2	I3	I4	I5	I6	I7	I8	A	B
YLAA0156HE	7.6	69	72.5	63.6	7.6	69	72.5	63.6	1.4	85.5
YLAA0170SE	7.6	69	72.5	63.6	7.6	69	72.5	63.6	1.4	85.5
YLAA0175HE	7.6	69	72.5	63.6	7.6	69	72.5	63.6	1.4	85.5

Isolator Details

ONE INCH DEFLECTION SPRING ISOLATOR CROSS-REFERENCE

CPX-X-

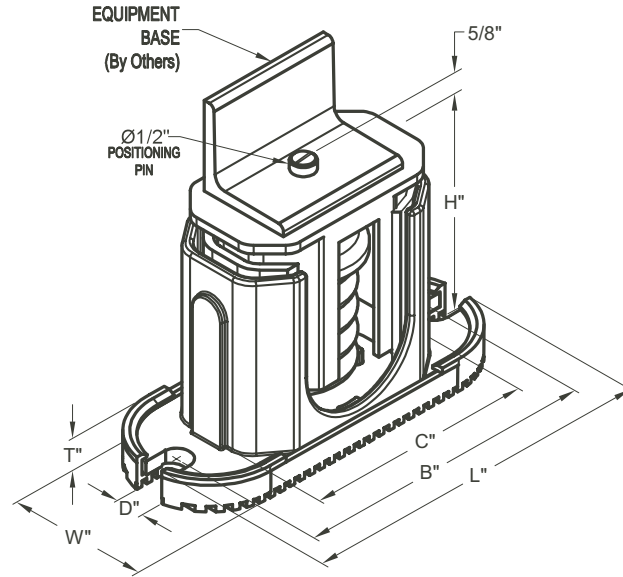

Mount Type	Dimension Data (Inches)						
	W	D	L	B	C	T	H
CP1	3	5/8	7-3/4	6-1/2	4-3/4	1/2	5-5/8
CP2	3	5/8	10-1/2	9-1/4	7-3/4	9/16	6

MODEL NUMBER	RATED CAPACITY (LBS.)	DEFLECTION RATED (IN)	COLOR CODE
CP1-1D-85	85	1.360	LT. PURPLE
CP1-1D-120	120	1.200	DK. YELLOW
CP1-1D-175	175	1.170	DK. BLUE
CP1-1D-250	250	1.400	YELLOW
CP1-1D-340	340	1.130	RED
CP1-1D-510	510	1.020	BLACK
CP1-1D-675	675	1.320	DK. PURPLE
CP1-1D-900	900	1.020	DK. GREEN
CP1-1D-1200	1200	0.900	GRAY
CP1-1D-1360	1360	0.770	WHITE
CP1-1D-1785N	1785	0.880	GRAY/RED

MODEL NUMBER	RATED CAPACITY (LBS.)	DEFLECTION RATED (IN)	COLOR CODE
CP2-1D-1020	1020	1.020	BLACK
CP2-1D-1350	1350	1.320	DK. PURPLE
CP2-1D-1800	1800	1.020	DK. GREEN
CP2-1D-2400	2400	0.900	GRAY
CP2-1D-2720	2720	0.770	WHITE
CP2-1D-3570N	3570	0.880	GRAY / RED

TWO INCH DEFLECTION, SEISMIC SPRING ISOLATOR CROSS-REFERENCE

Y2RS

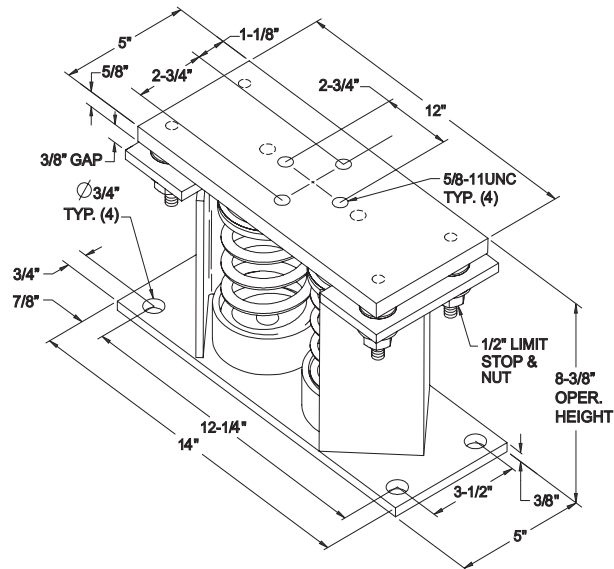

MODEL Y2RSI-2D SEISMICALLY RESTRAINED VIBRATION ISOLATOR FOR 2\" DEFLECTION

SEISMIC MOUNT SIZE	RATED LOAD (LBS)	RATED DEFLECTION (IN)	SPRING RATE (LBS/IN)	SOLID LOAD (LBS)	COLOR CODE	ALLOWABLE G RATING HORIZONTAL
Y2RSI-2D-150	150	2.4	62	234	WHITE	34.7
Y2RSI-2D-320	320	2.3	140	490	YELLOW	16.3
Y2RSI-2D-460	460	2.3	200	688	GREEN	11.3
Y2RSI-2D-710	710	2.2	330	1072	DK BROWN	7.3
Y2RSI-2D-870	870	1.9	460	1312	RED	6
Y2RSI-2D-1200N	1200	1.9	638	1818	RED/BLACK	4.3
Y2RSI-2D-1450	1450	1.8	900	2450	TAN	3.6
Y2RSI-2D-1690	1690	1.7	1140	2892	PINK	3.1
Y2RSI-2D-2000N	2000	1.7	1318	3342	PINK/BLACK	2.6
Y2RSI-2D-2640N	2640	1.5	1854	4283	PINK/GRAY	2
Y2RSI-2D-2870N	3080	1.5	2004	4629	PINK/GRAY/ORANGE	1.7
Y2RSI-2D-3280N	3740	1.8	2134	4930	PINK/GRAY/DK BROWN	1.4

Isolator Details - continued

ELASTOMERIC ISOLATOR CROSS-REFERENCE

RD-Style Isolators

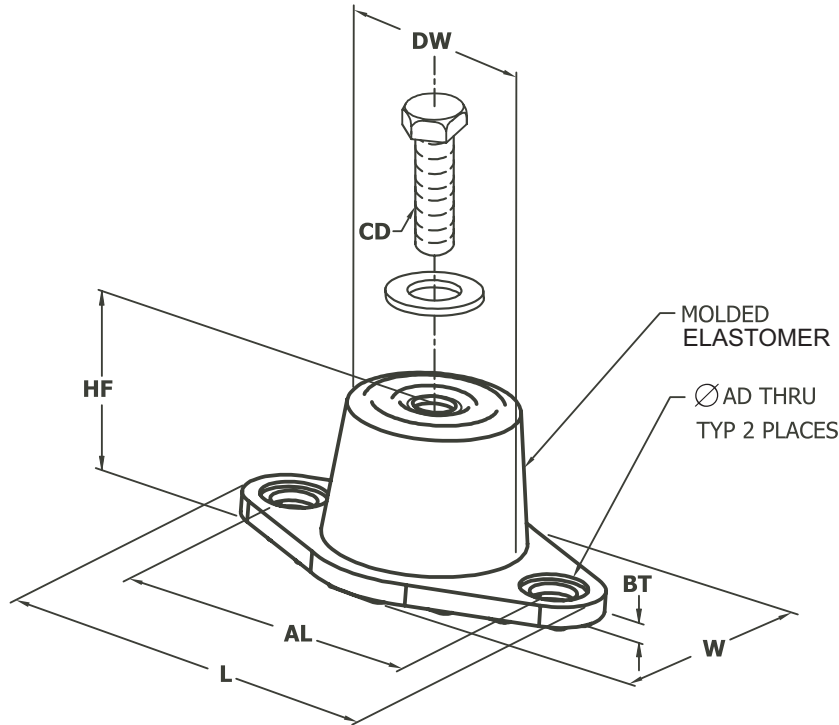

Mount Type	Dimension Data (inches)							
	L	W	HF	AL	AD	BT	CD	DW
RD1-WR	3.13	1.75	1.25	2.38	0.34	0.19	5/16-18 UNC X 3/4	1.25
RD2-WR	3.88	2.38	1.75	3.00	0.34	0.22	3/8-16 UNC X 1	1.75
RD3-WR	5.50	3.38	2.88	4.13	0.56	0.25	1/2-13 UNC X 1	2.50
RD4-WR	6.25	4.63	2.75	5.00	0.56	0.38	1/2-13 UNC X 1	3.00

MODEL NUMBER	RATED CAPACITY [LBS]	RATED DEFLECTION [IN]	DURO (± 5)
RD2-Light Blue-WR	35	0.4	30
RD2-Brown-WR	45	0.4	40
RD2-Brick Red-WR	70	0.4	50
RD 2-Lime-WR	120	0.4	60

MODEL NUMBER	RATED CAPACITY [LBS]	RATED DEFLECTION [IN]	DURO (± 5)
RD2-Light Blue-WR	135	0.5	30
RD2-Brown-WR	170	0.5	40
RD2-Brick Red-WR	240	0.5	50
RD 2-Lime-WR	380	0.5	60
RD2 Charcoal-WR	550	0.5	70

MODEL NUMBER	RATED CAPACITY [LBS]	RATED DEFLECTION [IN]	DURO (± 5)
RD3-Brown-WR	250	0.5	40
RD3-Brick Red-WR	525	0.5	50
RD3-Lime-WR	750	0.5	60
RD3-Charcoal-WR	1100	0.5	70

MODEL NUMBER	RATED CAPACITY [LBS]	RATED DEFLECTION [IN]	DURO (± 5)
RD4-Brown-WR	1500	0.5	40
RD4-Brick Red-WR	2250	0.5	50
RD4-Lime-WR	3000	0.5	60
RD4-Charcoal-WR	4000	0.5	70

Electrical Notes

NOTES:

1. Minimum Circuit Ampacity (MCA) is based on 125% of the rated load amps for the largest motor plus 100% of the rated load amps for all other loads included in the circuit, per N.E.C. Article 430-24. If the optional Factory Mounted Control Transformer is provided, add the following MCA values to the electrical tables for the system providing power to the transformer: -17, add 2.5 amps; -28, add 2.3 amps; -40, add 1.5 amps, -46, add 1.3 amps; -58, add 1 amps.
2. The minimum recommended disconnect switch is based on 115% of the rated load amps for all loads included in the circuit, per N.E.C. Article 440.
3. Minimum fuse size is based upon 150% of the rated load amps for the largest motor plus 100% of the rated load amps for all other loads included in the circuit to avoid nuisance trips at start-up due to lock rotor amps. It is not recommended in applications where brown outs, frequent starting and stopping of the unit, and/or operation at ambient temperatures in excess of 95°F (35°C) is anticipated.
4. Maximum fuse size is based upon 225% of the rated load amps for the largest motor plus 100% of the rated load amps for all other loads included in the circuit, per N.E.C. Article 440-22.
5. Circuit breakers must be UL listed and CSA certified and maximum size is based on 225% of the rated load amps for the largest motor plus 100% of the rated load amps for all other loads included in the circuit. Otherwise, HACR-type circuit breakers must be used. Maximum HACR circuit breaker rating is based on 225% of the rated load amps for the largest motor plus 100% of the rated load amps for all other loads included in the circuit.
6. The "INCOMING WIRE RANGE" is the minimum and maximum wire size that can be accommodated by the unit wiring lugs. The (2) preceding the wire range indicates the number of termination points available per phase of the wire range specified. Actual wire size and number of wires per phase must be determined based on the National Electrical Code, **using copper connectors only**. Field wiring must also comply with local codes.
7. A ground lug is provided for each compressor system to accommodate a field grounding conductor per N.E.C. Table 250-95. A control circuit grounding lug is also supplied.
8. The supplied disconnect is a "Disconnecting Means" as defined in the N.E.C. 100, and is intended for isolating the unit for the available power supply to perform maintenance and troubleshooting. This disconnect is not intended to be a Load Break Device.
9. Field Wiring by others which complies to the National Electrical Code & Local Codes.

LEGEND

ACR-LINE	ACROSS THE LINE START
C.B.	CIRCUIT BREAKER
D.E.	DUAL ELEMENT FUSE
DISC SW	DISCONNECT SWITCH
FACT MOUNT CB	FACTORY MOUNTED CIRCUIT BREAKER
FLA	FULL LOAD AMPS
HZ	HERTZ
MAX	MAXIMUM
MCA	MINIMUM CIRCUIT AMPACITY
MIN	MINIMUM
MIN NF	MINIMUM NON FUSED
RLA	RATED LOAD AMPS
S.P. WIRE	SINGLE POINT WIRING
UNIT MTD SERV SW	UNIT MOUNTED SERVICE (NON-FUSED DISCONNECT SWITCH)
LRA	LOCKED ROTOR AMPS

VOLTAGE CODE

-17	= 200-3-60
-28	= 230-3-60
-40	= 380-3-60
-46	= 460-3-60
-58	= 575-3-60

Electrical Data w/o Pumps

CHILLER MODEL & MIN CB & MAX CB	VOLT MAX DUAL ELEM FUSE	HZ	MINIMUM CIRCUIT AMPS	MIN N/F DISC SW	MIN DUAL ELEM FUSE	MAX DUAL ELEM FUSE & MAX CB	SYSTEM # 1								
							COMPR 1		COMPR 2		COMPR 3		COND FANS		
							RLA	LRA	RLA	LRA	RLA	LRA	QTY	FLA	LRA
YLAA0070 SE	200	60	351	400	400	400	51.3	300	51.3	300	51.3	300	2	7.6	30.9
	230	60	350	400	400	400	51.3	300	51.3	300	51.3	300	2	7.4	37.0
	380	60	186	250	200	200	26.9	139	26.9	139	26.9	139	2	4.5	22.3
	460	60	160	200	175	175	23.1	150	23.1	150	23.1	150	2	4.0	19.0
	575	60	136	200	150	150	19.9	109	19.9	109	19.9	109	2	2.9	14.6
YLAA0080 SE	200	60	366	600	400	400	55.8	425	55.8	425	55.8	425	2	7.6	30.9
	230	60	365	600	400	400	55.8	425	55.8	425	55.8	425	2	7.4	37.0
	380	60	216	250	225	250	36.0	239	36.0	239	36.0	239	2	4.5	22.3
	460	60	173	200	200	200	26.9	187	26.9	187	26.9	187	2	4.0	19.0
	575	60	148	200	175	175	23.7	148	23.7	148	23.7	148	2	2.9	14.6
YLAA0090 SE	200	60	391	600	450	500	55.8	425	55.8	425	55.8	425	2	7.6	30.9
	230	60	390	600	450	450	55.8	425	55.8	425	55.8	425	2	7.4	37.0
	380	60	249	400	300	300	36.0	239	36.0	239	36.0	239	2	4.5	22.3
	460	60	192	250	225	225	26.9	187	26.9	187	26.9	187	2	4.0	19.0
	575	60	168	200	200	200	23.7	148	23.7	148	23.7	148	2	2.9	14.6
YLAA0100 SE	200	60	452	600	500	500	55.8	425	55.8	425	55.8	425	2	7.6	30.9
	230	60	451	600	500	500	55.8	425	55.8	425	55.8	425	2	7.4	37.0
	380	60	286	400	350	350	36.0	239	36.0	239	36.0	239	2	4.5	22.3
	460	60	223	250	250	250	26.9	187	26.9	187	26.9	187	2	4.0	19.0
	575	60	197	250	225	225	23.7	148	23.7	148	23.7	148	2	2.9	14.6
YLAA0115 YLAA0120 SE	200	60	511	600	600	600	109.6	599	109.6	599			3	7.6	30.9
	230	60	510	600	600	600	109.6	599	109.6	599			3	7.4	37.0
	380	60	321	400	350	350	69.2	358	69.2	358			3	4.5	22.3
	460	60	256	400	300	300	54.5	310	54.5	310			3	4.0	19.0
	575	60	227	250	250	250	49.4	239	49.4	239			3	2.9	14.6
YLAA0135 SE	200	60	582	800	700	700	109.6	599	109.6	599	109.6	599	4	7.6	30.9
	230	60	581	800	700	700	109.6	599	109.6	599	109.6	599	4	7.4	37.0
	380	60	366	600	400	400	69.2	358	69.2	358	69.2	358	4	4.5	22.3
	460	60	291	400	350	350	54.5	310	54.5	310	54.5	310	4	4.0	19.0
	575	60	257	400	300	300	49.4	239	49.4	239	49.4	239	4	2.9	14.6
YLAA0150 YLAA0155 SE	200	60	636	800	700	700	109.6	599	109.6	599	109.6	599	4	7.6	30.9
	230	60	635	800	700	700	109.6	599	109.6	599	109.6	599	4	7.4	37.0
	380	60	399	600	450	450	69.2	358	69.2	358	69.2	358	4	4.5	22.3
	460	60	318	400	350	350	54.5	310	54.5	310	54.5	310	4	4.0	19.0
	575	60	283	400	300	300	49.4	239	49.4	239	49.4	239	4	2.9	14.6
YLAA0170 HE	200	60	761	1000	800	800	109.6	599	109.6	599	109.6	599	5	7.6	30.9
	230	60	759	1000	800	800	109.6	599	109.6	599	109.6	599	5	7.4	37.0
	380	60	478	600	500	500	69.2	358	69.2	358	69.2	358	5	4.5	22.3
	460	60	381	600	400	400	54.5	310	54.5	310	54.5	310	5	4.0	19.0
	575	60	338	400	400	400	49.4	239	49.4	239	49.4	239	5	2.9	14.6

CHILLER MODEL & MIN CB & MAX CB	VOLT MAX DUAL ELEM FUSE	HZ	SYSTEM # 2								
			COMPR 1		COMPR 2		COMPR 3		COND FANS		
			RLA	LRA	RLA	LRA	RLA	LRA	QTY	FLA	LRA
YLAA0070 SE	200	60	51.3	300	51.3	300	51.3	300	2	7.6	30.9
	230	60	51.3	300	51.3	300	51.3	300	2	7.4	37.0
	380	60	26.9	139	26.9	139	26.9	139	2	4.5	22.3
	460	60	23.1	150	23.1	150	23.1	150	2	4.0	19.0
	575	60	19.9	109	19.9	109	19.9	109	2	2.9	14.6
YLAA0080 SE	200	60	51.3	300	51.3	300	51.3	300	2	7.6	30.9
	230	60	51.3	300	51.3	300	51	300	2	7.4	37.0
	380	60	26.9	139	26.9	139	26.9	139	2	4.5	22.3
	460	60	23.1	150	23.1	150	23.1	150	2	4.0	19.0
	575	60	19.9	109	19.9	109	19.9	109	2	2.9	14.6
YLAA0090 SE	200	60	109.6	599	55.8	425			2	7.6	30.9
	230	60	109.6	599	55.8	425			2	7.4	37.0
	380	60	69.2	358	36.0	239			2	4.5	22.3
	460	60	54.5	310	26.9	187			2	4.0	19.0
	575	60	49.4	239	23.7	148			2	2.9	14.6
YLAA0100 SE	200	60	109.6	599	110.0	599			3	7.6	30.9
	230	60	109.6	599	110.0	599			3	7.4	37.0
	380	60	69.2	358	69.2	358			3	4.5	22.3
	460	60	54.5	310	54.5	310			3	4.0	19.0
	575	60	49.4	239	49.4	239			3	2.9	14.6
YLAA0115 YLAA0120 SE	200	60	109.6	599	109.6	599			3	7.6	30.9
	230	60	109.6	599	109.6	599			3	7.4	37.0
	380	60	69.2	358	69.2	358			3	4.5	22.3
	460	60	54.5	310	54.5	310			3	4.0	19.0
	575	60	49.4	239	49.4	239			3	2.9	14.6
YLAA0135 SE	200	60	109.6	599	55.8	425			4	7.6	30.9
	230	60	109.6	599	55.8	425			4	7.4	37.0
	380	60	69.2	358	36.0	239			4	4.5	22.3
	460	60	54.5	310	26.9	187			4	4.0	19.0
	575	60	49.4	239	23.7	148			4	2.9	14.6
YLAA0150 YLAA0155 SE	200	60	109.6	599	109.6	599			4	7.6	30.9
	230	60	109.6	599	109.6	599			4	7.4	37.0
	380	60	69.2	358	69.2	358			4	4.5	22.3
	460	60	54.5	310	54.5	310			4	4.0	19.0
	575	60	49.4	239	49.4	239			4	2.9	14.6
YLAA0170 HE	200	60	109.6	599	110.0	599	109.6	599	5	7.6	30.9
	230	60	109.6	599	110.0	599	109.6	599	5	7.4	37.0
	380	60	69.2	358	69.2	358	69.2	358	5	4.5	22.3
	460	60	54.5	310	54.5	310	54.5	310	5	4.0	19.0
	575	60	49.4	239	49.4	239	49.4	239	5	2.9	14.6

Electrical Data w/o Pumps - continued

CHILLER MODEL & MIN CB & MAX CB	VOLT MAX DUAL ELEM FUSE	HZ	MINIMUM CIRCUIT AMPS	MIN N/F DISC SW	MIN DUAL ELEM FUSE	MAX DUAL ELEM FUSE & MAX CB	SYSTEM # 1								
							COMPR 1		COMPR 2		COMPR 3		COND FANS		
							RLA	LRA	RLA	LRA	RLA	LRA	QTY	FLA	LRA
YLAA0091 HE	200	60	404	600	450	500	109.6	599	55.8	425			3	7.6	30.9
	230	60	403	600	450	500	109.6	358	55.8	425			3	7.4	37.0
	380	60	255	400	300	300	69.2	310	36.0	239			3	4.5	22.3
	460	60	200	250	225	250	54.5	239	26.9	187			3	4.0	19.0
	575	60	176	200	200	225	49.4	310	23.7	148			3	2.9	14.6
YLAA0101 HE	200	60	460	600	500	500	55.8	425	55.8	425	55.8	425	2	7.6	30.9
	230	60	458	600	500	500	55.8	425	55.8	425	55.8	425	2	7.4	37.0
	380	60	291	400	350	350	36.0	239	36.0	239	36.0	239	2	4.5	22.3
	460	60	227	250	250	250	26.9	187	26.9	187	26.9	187	2	4.0	19.0
	575	60	200	250	225	225	23.7	148	23.7	148	23.7	148	2	2.9	14.6
YLAA0125 HE	200	60	527	600	600	600	109.6	599	109.6	599			4	7.6	30.9
	230	60	525	600	600	600	109.6	599	109.6	599			4	7.4	37.0
	380	60	330	400	350	350	69.2	358	69.2	358			4	4.5	22.3
	460	60	264	400	300	300	54.5	310	54.5	310			4	4.0	19.0
	575	60	233	400	250	250	49.4	239	49.4	239			4	2.9	14.6
YLAA0141 HE	200	60	582	800	700	700	109.6	599	109.6	599	109.6	599	5	7.6	30.9
	230	60	581	800	700	700	109.6	599	109.6	599	109.6	599	5	7.4	37.0
	380	60	366	600	400	400	69.2	358	69.2	358	69.2	358	5	4.5	22.3
	460	60	291	400	350	350	54.5	310	54.5	310	54.5	310	5	4.0	19.0
	575	60	257	400	300	300	49.4	239	49.4	239	49.4	239	5	2.9	14.6
YLAA0156 HE	200	60	651	800	700	700	109.6	599	109.6	599	109.6	599	6	7.6	30.9
	230	60	649	800	700	700	109.6	599	109.6	599	109.6	599	6	7.4	37.0
	380	60	408	600	450	450	69.2	358	69.2	358	69.2	358	6	4.5	22.3
	460	60	326	400	350	350	54.5	310	54.5	310	54.5	310	6	4.0	19.0
	575	60	288	400	350	350	49.4	239	49.4	239	49.4	239	6	2.9	14.6
YLAA0175 HE	200	60	761	1000	800	800	109.6	599	109.6	599	109.6	599	5	7.6	30.9
	230	60	759	1000	800	800	109.6	599	109.6	599	109.6	599	5	7.4	37.0
	380	60	478	600	500	500	69.2	358	69.2	358	69.2	358	5	4.5	22.3
	460	60	381	600	400	400	54.5	310	54.5	310	54.5	310	5	4.0	19.0
	575	60	338	400	400	400	49.4	239	49.4	239	49.4	239	5	2.9	14.6

CHILLER MODEL & MIN CB & MAX CB	VOLT MAX DUAL ELEM FUSE	HZ	SYSTEM # 2								
			COMPR 1		COMPR 2		COMPR 3		COND FANS		
			RLA	LRA	RLA	LRA	RLA	LRA	QTY	FLA	LRA
YLAA0091 HE	200	60	109.6	599	55.8	425			3	7.6	30.9
	230	60	109.6	599	55.8	425			3	7.4	37.0
	380	60	69.2	358	36.0	239			3	4.5	22.3
	460	60	54.5	310	26.9	187			3	4.0	19.0
	575	60	49.4	239	23.7	148			3	2.9	14.6
YLAA0101 HE	200	60	109.6	599	109.6	599			4	7.6	30.9
	230	60	109.6	599	109.6	599			4	7.4	37.0
	380	60	69.2	358	69.2	358			4	4.5	22.3
	460	60	54.5	310	54.5	310			4	4.0	19.0
	575	60	49.4	239	49.4	239			4	2.9	14.6
YLAA0125 HE	200	60	109.6	599	110.0	599			4	7.6	30.9
	230	60	109.6	599	110.0	599			4	7.4	37.0
	380	60	69.2	358	69.2	358			4	4.5	22.3
	460	60	54.5	310	54.5	310			4	4.0	19.0
	575	60	49.4	239	49.4	239			4	2.9	14.6
YLAA0141 HE	200	60	109.6	599	55.8	425			3	7.6	30.9
	230	60	109.6	599	55.8	425			3	7.4	37.0
	380	60	69.2	358	36.0	239			3	4.5	22.3
	460	60	54.5	310	26.9	187			3	4.0	19.0
	575	60	49.4	239	23.7	148			3	2.9	14.6
YLAA0156 HE	200	60	109.6	599	109.6	599			4	7.6	30.9
	230	60	109.6	599	110.0	599			4	7.4	37.0
	380	60	69.2	358	69.2	358			4	4.5	22.3
	460	60	54.5	310	54.5	310			4	4.0	19.0
	575	60	49.4	239	49.4	239			4	2.9	14.6
YLAA0175 HE	200	60	109.6	599	110.0	599	109.6	599	5	7.6	30.9
	230	60	109.6	599	110.0	599	109.6	599	5	7.4	37.0
	380	60	69.2	358	69.2	358	69.2	358	5	4.5	22.3
	460	60	54.5	310	54.5	310	54.5	310	5	4.0	19.0
	575	60	49.4	239	49.4	239	49.4	239	5	2.9	14.6

Wiring Lugs

CHILLER MODEL	VOLT	HZ	TERMINAL BLOCK LUGS	NON FUSED DISCONNECT SWITCH LUGS	TERMINAL BLOCK LUGS
YLAA0070	200	60	(1) #4 - 500 kcmil	(2)250 - 500kcmil & (3)2/0 - 400kcmil	(2)250 - 500kcmil & (3)2/0 - 400kcmil
	230	60	(1) #4 - 500 kcmil	(2)250 - 500kcmil & (3)2/0 - 400kcmil	(2)250 - 500kcmil & (3)2/0 - 400kcmil
	380	60	(1) #4 - 500 kcmil	(1) #6 - 350 kcmil	(1) #6 - 350 kcmil
	460	60	(1) #4 - 500 kcmil	(1) #6 - 350 kcmil	(1) #6 - 350 kcmil
	575	60	(1) #4 - 500 kcmil	(1) #6 - 350 kcmil	(1) #6 - 350 kcmil
YLAA0080	200	60	(1) #4 - 500 kcmil	(2)250 - 500kcmil & (3)2/0 - 400kcmil	(2)250 - 500kcmil & (3)2/0 - 400kcmil
	230	60	(1) #4 - 500 kcmil	(2)250 - 500kcmil & (3)2/0 - 400kcmil	(2)250 - 500kcmil & (3)2/0 - 400kcmil
	380	60	(1) #4 - 500 kcmil	250 - 500kcmil & (2)3/0 - 250kcmil	250 - 500kcmil & (2)3/0 - 250kcmil
	460	60	(1) #4 - 500 kcmil	(1) #6 - 350 kcmil	(1) #6 - 350 kcmil
	575	60	(1) #4 - 500 kcmil	(1) #6 - 350 kcmil	(1) #6 - 350 kcmil
YLAA0090	200	60	(2) #6 - 500 kcmil	(2)250 - 500kcmil & (3)2/0 - 400kcmil	(2)250 - 500kcmil & (3)2/0 - 400kcmil
	230	60	(2) #6 - 500 kcmil	(2)250 - 500kcmil & (3)2/0 - 400kcmil	(2)250 - 500kcmil & (3)2/0 - 400kcmil
	380	60	(1) #4 - 500 kcmil	250 - 500kcmil & (2)3/0 - 250kcmil	250 - 500kcmil & (2)3/0 - 250kcmil
	460	60	(1) #4 - 500 kcmil	(1) #6 - 350 kcmil	(1) #6 - 350 kcmil
	575	60	(1) #4 - 500 kcmil	(1) #6 - 350 kcmil	(1) #6 - 350 kcmil
YLAA0091	200	60	(2) #6 - 500 kcmil	(2)250 - 500kcmil & (3)2/0 - 400kcmil	(2)250 - 500kcmil & (3)2/0 - 400kcmil
	230	60	(2) #6 - 500 kcmil	(2)250 - 500kcmil & (3)2/0 - 400kcmil	(2)250 - 500kcmil & (3)2/0 - 400kcmil
	380	60	(1) #4 - 500 kcmil	250 - 500kcmil & (2)3/0 - 250kcmil	250 - 500kcmil & (2)3/0 - 250kcmil
	460	60	(1) #4 - 500 kcmil	(1) #6 - 350 kcmil	(1) #6 - 350 kcmil
	575	60	(1) #4 - 500 kcmil	(1) #6 - 350 kcmil	(1) #6 - 350 kcmil
P1: YLAA0101 P2: YLAA0100	200	60	(2) #6 - 500 kcmil	(2)250 - 500kcmil & (3)2/0 - 400kcmil	(2)250 - 500kcmil & (3)2/0 - 400kcmil
	230	60	(2) #6 - 500 kcmil	(2)250 - 500kcmil & (3)2/0 - 400kcmil	(2)250 - 500kcmil & (3)2/0 - 400kcmil
	380	60	(1) #4 - 500 kcmil	250 - 500kcmil & (2)3/0 - 250kcmil	250 - 500kcmil & (2)3/0 - 250kcmil
	460	60	(1) #4 - 500 kcmil	250 - 500kcmil & (2)3/0 - 250kcmil	250 - 500kcmil & (2)3/0 - 250kcmil
	575	60	(1) #4 - 500 kcmil	(1) #6 - 350 kcmil	(1) #6 - 350 kcmil

CHILLER MODEL	VOLT	HZ	TERMINAL BLOCK LUGS	NON FUSED DISCONNECT SWITCH LUGS	TERMINAL BLOCK LUGS
P1: YLAA0115 & YLAA0120 P2: YLAA0125	200	60	(2) #6 - 500 kcmil	(2)250 - 500kcmil & (3)2/0 - 400kcmil	(2)250 - 500kcmil & (3)2/0 - 400kcmil
	230	60	(2) #6 - 500 kcmil	(2)250 - 500kcmil & (3)2/0 - 400kcmil	(2)250 - 500kcmil & (3)2/0 - 400kcmil
	380	60	(1) #4 - 500 kcmil	250 - 500kcmil & (2)3/0 - 250kcmil	250 - 500kcmil & (2)3/0 - 250kcmil
	460	60	(1) #4 - 500 kcmil	250 - 500kcmil & (2)3/0 - 250kcmil	250 - 500kcmil & (2)3/0 - 250kcmil
	575	60	(1) #4 - 500 kcmil	250 - 500kcmil & (2)3/0 - 250kcmil	250 - 500kcmil & (2)3/0 - 250kcmil
P1: YLAA0135 P2: YLAA0141	200	60	(2) #6 - 500 kcmil	(2)250 - 500kcmil & (3)2/0 - 400kcmil	(2)250 - 500kcmil & (3)2/0 - 400kcmil
	230	60	(2) #6 - 500 kcmil	(2)250 - 500kcmil & (3)2/0 - 400kcmil	(2)250 - 500kcmil & (3)2/0 - 400kcmil
	380	60	(1) #4 - 500 kcmil	(2)250 - 500kcmil & (3)2/0 - 400kcmil	250 - 500kcmil & (2)3/0 - 250kcmil
	460	60	(1) #4 - 500 kcmil	250 - 500kcmil & (2)3/0 - 250kcmil	250 - 500kcmil & (2)3/0 - 250kcmil
	575	60	(1) #4 - 500 kcmil	250 - 500kcmil & (2)3/0 - 250kcmil	250 - 500kcmil & (2)3/0 - 250kcmil
P1: YLAA0150 & YLAA0155 P2: YLAA0156	200	60	(2) #6 - 500 kcmil	(2)250 - 500kcmil & (3)2/0 - 400kcmil	(2)250 - 500kcmil & (3)2/0 - 400kcmil
	230	60	(2) #6 - 500 kcmil	(2)250 - 500kcmil & (3)2/0 - 400kcmil	(2)250 - 500kcmil & (3)2/0 - 400kcmil
	380	60	(2) #6 - 500 kcmil	(2)250 - 500kcmil & (3)2/0 - 400kcmil	(2)250 - 500kcmil & (3)2/0 - 400kcmil
	460	60	(1) #4 - 500 kcmil	250 - 500kcmil & (2)3/0 - 250kcmil	250 - 500kcmil & (2)3/0 - 250kcmil
	575	60	(1) #4 - 500 kcmil	250 - 500kcmil & (2)3/0 - 250kcmil	250 - 500kcmil & (2)3/0 - 250kcmil
P2: YLAA0170 & YLAA0175	200	60	(2) #6 - 500 kcmil	(4) 4/0 - 500kcmil	(2)250 - 500kcmil & (3)2/0 - 400kcmil
	230	60	(2) #6 - 500 kcmil	(4) 4/0 - 500kcmil	(2)250 - 500kcmil & (3)2/0 - 400kcmil
	380	60	(2) #6 - 500 kcmil	(2)250 - 500kcmil & (3)2/0 - 400kcmil	(2)250 - 500kcmil & (3)2/0 - 400kcmil
	460	60	(2) #6 - 500 kcmil	(2)250 - 500kcmil & (3)2/0 - 400kcmil	(2)250 - 500kcmil & (3)2/0 - 400kcmil
	575	60	(1) #4 - 500 kcmil	(2)250 - 500kcmil & (3)2/0 - 400kcmil	250 - 500kcmil & (2)3/0 - 250kcmil

Electrical Data w/ Pumps

CHILLER MODEL	VOLT	HZ	Pump Model	Pump	MINIMUM CIRCUIT AMPS	MIN N/F DISC SW	MIN DUAL ELEM FUSE & MIN CB	MAX DUAL ELEM FUSE & MAX CB
YLAA0070 SE	200	60	A, K	15.4	366	600	400	400
	230	60		13.9	364	600	400	400
	380	60		8.1	194	250	225	225
	460	60		7.0	167	200	175	175
	575	60		5.6	142	200	150	150
YLAA0070 SE	200	60	B	21.4	372	600	400	400
	230	60		20.4	371	600	400	400
	380	60		12.0	198	250	225	225
	460	60		10.2	171	200	200	200
	575	60		8.2	144	200	150	150
YLAA0070 SE	200	60	C	32.2	383	600	400	400
	230	60		28.4	379	600	400	400
	380	60		15.4	202	250	225	225
	460	60		14.2	175	200	200	200
	575	60		11.4	147	200	175	175
YLAA0070 SE	200	60	D, M, N	41.7	393	600	450	450
	230	60		36.3	387	600	400	400
	380	60		22.0	208	250	225	225
	460	60		18.2	179	200	200	200
	575	60		14.5	150	200	175	175
YLAA0070 SE	200	60	L	27.1	378	600	400	400
	230	60		24.5	375	600	400	400
	380	60		14.8	201	250	225	225
	460	60		12.3	173	200	200	200
	575	60		9.8	146	200	175	175
YLAA0080 SE	200	60	A, K	15.4	381	600	400	400
	230	60		13.9	379	600	400	400
	380	60		8.1	224	250	250	250
	460	60		7.0	180	200	200	200
	575	60		5.6	154	200	175	175
YLAA0080 SE	200	60	B	21.4	387	600	450	450
	230	60		20.4	385	600	400	400
	380	60		12.0	228	400	250	250
	460	60		10.2	183	250	200	200
	575	60		8.2	157	200	175	175
YLAA0080 SE	200	60	C	32.2	398	600	450	450
	230	60		28.4	393	600	450	450
	380	60		15.4	231	400	250	250
	460	60		14.2	187	250	200	200
	575	60		11.4	160	200	175	175
YLAA0080 SE	200	60	D, M, N	41.7	407	600	450	450
	230	60		36.3	401	600	450	450
	380	60		22.0	238	400	250	250
	460	60		18.2	191	250	200	200
	575	60		14.5	163	200	175	175

Electrical Data w/ Pumps - continued

CHILLER MODEL	VOLT	HZ	Pump Model	Pump	MINIMUM CIRCUIT AMPS	MIN N/F DISC SW	MIN DUAL ELEM FUSE & MIN CB	MAX DUAL ELEM FUSE & MAX CB
YLAA0080 SE	200	60	L	27.1	393	600	450	450
	230	60		24.5	389	600	450	450
	380	60		14.8	231	400	250	250
	460	60		12.3	185	250	200	200
	575	60		9.8	158	200	175	175
YLAA0090 SE	200	60	A, K	15.4	406	600	450	500
	230	60		13.9	404	600	450	500
	380	60		8.1	257	400	300	300
	460	60		7.0	199	250	225	250
	575	60		5.6	174	200	200	200
YLAA0090 SE	200	60	B	21.4	412	600	450	500
	230	60		20.4	410	600	450	500
	380	60		12.0	261	400	300	300
	460	60		10.2	202	250	225	250
	575	60		8.2	176	200	200	225
YLAA0090 SE	200	60	D, M, N	41.7	432	600	500	500
	230	60		36.3	426	600	500	500
	380	60		22.0	271	400	300	300
	460	60		18.2	210	250	225	250
	575	60		14.5	183	200	200	225
YLAA0090 SE	200	60	E	54.7	445	600	500	500
	230	60		49.5	439	600	500	500
	380	60		29.1	278	400	300	300
	460	60		24.8	217	250	250	250
	575	60		19.8	188	250	225	225
YLAA0090 SE	200	60	L	27.1	418	600	450	500
	230	60		24.5	414	600	450	500
	380	60		14.8	263	400	300	300
	460	60		12.3	204	250	225	250
	575	60		9.8	178	200	200	225
YLAA0091 HE	200	60	A, K	15.4	419	600	450	500
	230	60		13.9	417	600	450	500
	380	60		8.1	263	400	300	300
	460	60		7.0	207	250	225	250
	575	60		5.6	182	200	200	225
YLAA0091 HE	200	60	B	21.4	425	600	500	500
	230	60		20.4	423	600	500	500
	380	60		12.0	267	400	300	300
	460	60		10.2	211	250	225	250
	575	60		8.2	184	200	200	225
YLAA0091 HE	200	60	D, M, N	41.7	446	600	500	500
	230	60		36.3	439	600	500	500
	380	60		22.0	277	400	300	300
	460	60		18.2	219	250	250	250
	575	60		14.5	190	250	225	225

SYSTEM # 1									SYSTEM # 2								
COMPR 1		COMPR 2		COMPR 3		COND FANS			COMPR 1		COMPR 2		COMPR 3		COND FANS		
RLA	LRA	RLA	LRA	RLA	LRA	QTY	FLA	LRA	RLA	LRA	RLA	LRA	RLA	LRA	QTY	FLA	LRA
55.8	425	55.8	425	55.8	425	2	7.6	30.9	51.3	300	51.3	300	51.3	300	2	7.6	30.9
55.8	425	55.8	425	55.8	425	2	7.4	37.0	51.3	300	51.3	300	51.3	300	2	7.4	37.0
36.0	239	36.0	239	36.0	239	2	4.5	22.3	26.9	139	26.9	139	26.9	139	2	4.5	22.3
26.9	187	26.9	187	26.9	187	2	4.0	19.0	23.1	150	23.1	150	23.1	150	2	4.0	19.0
23.7	148	23.7	148	23.7	148	2	2.9	14.6	19.9	109	19.9	109	19.9	109	2	2.9	14.6
55.8	425	55.8	425	55.8	425	2	7.6	30.9	109.6	599	55.8	425			2	7.6	30.9
55.8	425	55.8	425	55.8	425	2	7.4	37.0	109.6	599	55.8	425			2	7.4	37.0
36.0	239	36.0	239	36.0	239	2	4.5	22.3	69.2	358	36.0	239			2	4.5	22.3
26.9	187	26.9	187	26.9	187	2	4.0	19.0	54.5	310	26.9	187			2	4.0	19.0
23.7	148	23.7	148	23.7	148	2	2.9	14.6	49.4	239	23.7	148			2	2.9	14.6
55.8	425	55.8	425	55.8	425	2	7.6	30.9	109.6	599	55.8	425			2	7.6	30.9
55.8	425	55.8	425	55.8	425	2	7.4	37.0	109.6	599	55.8	425			2	7.4	37.0
36.0	239	36.0	239	36.0	239	2	4.5	22.3	69.2	358	36.0	239			2	4.5	22.3
26.9	187	26.9	187	26.9	187	2	4.0	19.0	54.5	310	26.9	187			2	4.0	19.0
23.7	148	23.7	148	23.7	148	2	2.9	14.6	49.4	239	23.7	148			2	2.9	14.6
55.8	425	55.8	425	55.8	425	2	7.6	30.9	109.6	599	55.8	425			2	7.6	30.9
55.8	425	55.8	425	55.8	425	2	7.4	37.0	109.6	599	55.8	425			2	7.4	37.0
36.0	239	36.0	239	36.0	239	2	4.5	22.3	69.2	358	36.0	239			2	4.5	22.3
26.9	187	26.9	187	26.9	187	2	4.0	19.0	54.5	310	26.9	187			2	4.0	19.0
23.7	148	23.7	148	23.7	148	2	2.9	14.6	49.4	239	23.7	148			2	2.9	14.6
55.8	425	55.8	425	55.8	425	2	7.6	30.9	109.6	599	55.8	425			2	7.6	30.9
55.8	425	55.8	425	55.8	425	2	7.4	37.0	109.6	599	55.8	425			2	7.4	37.0
36.0	239	36.0	239	36.0	239	2	4.5	22.3	69.2	358	36.0	239			2	4.5	22.3
26.9	187	26.9	187	26.9	187	2	4.0	19.0	54.5	310	26.9	187			2	4.0	19.0
23.7	148	23.7	148	23.7	148	2	2.9	14.6	49.4	239	23.7	148			2	2.9	14.6
55.8	425	55.8	425	55.8	425	2	7.6	30.9	109.6	599	55.8	425			2	7.6	30.9
55.8	425	55.8	425	55.8	425	2	7.4	37.0	109.6	599	55.8	425			2	7.4	37.0
36.0	239	36.0	239	36.0	239	2	4.5	22.3	69.2	358	36.0	239			2	4.5	22.3
26.9	187	26.9	187	26.9	187	2	4.0	19.0	54.5	310	26.9	187			2	4.0	19.0
23.7	148	23.7	148	23.7	148	2	2.9	14.6	49.4	239	23.7	148			2	2.9	14.6
109.6	599	55.8	425			3	7.6	30.9	109.6	599	55.8	425			3	7.6	30.9
109.6	358	55.8	425			3	7.4	37.0	109.6	599	55.8	425			3	7.4	37.0
69.2	310	36.0	239			3	4.5	22.3	69.2	358	36.0	239			3	4.5	22.3
54.5	239	26.9	187			3	4.0	19.0	54.5	310	26.9	187			3	4.0	19.0
49.4	310	23.7	148			3	2.9	14.6	49.4	239	23.7	148			3	2.9	14.6
109.6	599	55.8	425			3	7.6	30.9	109.6	599	55.8	425			3	7.6	30.9
109.6	358	55.8	425			3	7.4	37.0	109.6	599	55.8	425			3	7.4	37.0
69.2	310	36.0	239			3	4.5	22.3	69.2	358	36.0	239			3	4.5	22.3
54.5	239	26.9	187			3	4.0	19.0	54.5	310	26.9	187			3	4.0	19.0
49.4	310	23.7	148			3	2.9	14.6	49.4	239	23.7	148			3	2.9	14.6
109.6	599	55.8	425			3	7.6	30.9	109.6	599	55.8	425			3	7.6	30.9
109.6	358	55.8	239			3	7.4	37.0	109.6	599	55.8	425			3	7.4	37.0
69.2	310	36.0	187			3	4.5	22.3	69.2	358	36.0	239			3	4.5	22.3
54.5	239	26.9	148			3	4.0	19.0	54.5	310	26.9	187			3	4.0	19.0
49.4	310	23.7	425			3	2.9	14.6	49.4	239	23.7	148			3	2.9	14.6

Electrical Data w/ Pumps - continued

CHILLER MODEL	VOLT	HZ	Pump Model	Pump	MINIMUM CIRCUIT AMPS	MIN N/F DISC SW	MIN DUAL ELEM FUSE & MIN CB	MAX DUAL ELEM FUSE & MAX CB
YLAA0091 HE	200	60	E	54.7	459	600	500	500
	230	60		49.5	452	600	500	500
	380	60		29.1	284	400	350	350
	460	60		24.8	225	250	250	250
	575	60		19.8	196	250	225	225
YLAA0091 HE	200	60	L	27.1	431	600	500	500
	230	60		24.5	427	600	500	500
	380	60		14.8	270	400	300	300
	460	60		12.3	213	250	250	250
	575	60		9.8	186	200	200	225
YLAA0101 HE	200	60	B, F	21.4	481	600	600	600
	230	60		20.4	479	600	600	600
	380	60		12.0	303	400	350	350
	460	60		10.2	238	400	300	300
	575	60		8.2	208	250	225	250
YLAA0101 HE	200	60	D, O	41.7	501	600	600	600
	230	60		36.3	495	600	600	600
	380	60		22.0	313	400	350	350
	460	60		18.2	246	400	300	300
	575	60		14.5	214	250	250	250
YLAA0101 HE	200	60	E, P	54.7	514	600	600	600
	230	60		49.5	508	600	600	600
	380	60		29.1	320	400	350	350
	460	60		24.8	252	400	300	300
	575	60		19.8	219	250	250	250
YLAA0101 HE	200	60	K	15.4	475	600	600	600
	230	60		13.9	472	600	500	500
	380	60		8.1	299	400	350	350
	460	60		7.0	234	400	250	250
	575	60		5.6	205	250	225	250
YLAA0101 HE	200	60	L	27.1	487	600	600	600
	230	60		24.5	483	600	600	600
	380	60		14.8	306	400	350	350
	460	60		12.3	240	400	300	300
	575	60		9.8	209	250	225	250
YLAA0115 YLAA0120 SE	200	60	F	21.4	533	600	600	600
	230	60		20.4	531	600	600	600
	380	60		12.0	333	400	400	400
	460	60		10.2	266	400	300	300
	575	60		8.2	236	400	250	250
YLAA0115 YLAA0120 SE	200	60	C	32.2	544	600	600	600
	230	60		28.4	539	600	600	600
	380	60		15.4	337	400	400	400
	460	60		14.2	270	400	300	300
	575	60		11.4	239	400	300	300

SYSTEM # 1									SYSTEM # 2								
COMPR 1		COMPR 2		COMPR 3		COND FANS			COMPR 1		COMPR 2		COMPR 3		COND FANS		
RLA	LRA	RLA	LRA	RLA	LRA	QTY	FLA	LRA	RLA	LRA	RLA	LRA	RLA	LRA	QTY	FLA	LRA
109.6	599	55.8	425			3	7.6	30.9	109.6	599	55.8	425			3	7.6	30.9
109.6	358	55.8	425			3	7.4	37.0	109.6	599	55.8	425			3	7.4	37.0
69.2	310	36.0	239			3	4.5	22.3	69.2	358	36.0	239			3	4.5	22.3
54.5	239	26.9	187			3	4.0	19.0	54.5	310	26.9	187			3	4.0	19.0
49.4	310	23.7	148			3	2.9	14.6	49.4	239	23.7	148			3	2.9	14.6
109.6	599	55.8	425			3	7.6	30.9	109.6	599	55.8	425			3	7.6	30.9
109.6	358	55.8	425			3	7.4	37.0	109.6	599	55.8	425			3	7.4	37.0
69.2	310	36.0	239			3	4.5	22.3	69.2	358	36.0	239			3	4.5	22.3
54.5	239	26.9	187			3	4.0	19.0	54.5	310	26.9	187			3	4.0	19.0
49.4	310	23.7	148			3	2.9	14.6	49.4	239	23.7	148			3	2.9	14.6
55.8	425	55.8	425	55.8	425	2	7.6	30.9	109.6	599	109.6	599			4	7.6	30.9
55.8	425	55.8	425	55.8	425	2	7.4	37.0	109.6	599	109.6	599			4	7.4	37.0
36.0	239	36.0	239	36.0	239	2	4.5	22.3	69.2	358	69.2	358			4	4.5	22.3
26.9	187	26.9	187	26.9	187	2	4.0	19.0	54.5	310	54.5	310			4	4.0	19.0
23.7	148	23.7	148	23.7	148	2	2.9	14.6	49.4	239	49.4	239			4	2.9	14.6
55.8	425	55.8	425	55.8	425	2	7.6	30.9	109.6	599	109.6	599			4	7.6	30.9
55.8	425	55.8	425	55.8	425	2	7.4	37.0	109.6	599	109.6	599			4	7.4	37.0
36.0	239	36.0	239	36.0	239	2	4.5	22.3	69.2	358	69.2	358			4	4.5	22.3
26.9	187	26.9	187	26.9	187	2	4.0	19.0	54.5	310	54.5	310			4	4.0	19.0
23.7	148	23.7	148	23.7	148	2	2.9	14.6	49.4	239	49.4	239			4	2.9	14.6
55.8	425	55.8	425	55.8	425	2	7.6	30.9	109.6	599	109.6	599			4	7.6	30.9
55.8	425	55.8	425	55.8	425	2	7.4	37.0	109.6	599	109.6	599			4	7.4	37.0
36.0	239	36.0	239	36.0	239	2	4.5	22.3	69.2	358	69.2	358			4	4.5	22.3
26.9	187	26.9	187	26.9	187	2	4.0	19.0	54.5	310	54.5	310			4	4.0	19.0
23.7	148	23.7	148	23.7	148	2	2.9	14.6	49.4	239	49.4	239			4	2.9	14.6
55.8	425	55.8	425	55.8	425	2	7.6	30.9	109.6	599	109.6	599			4	7.6	30.9
55.8	425	55.8	425	55.8	425	2	7.4	37.0	109.6	599	109.6	599			4	7.4	37.0
36.0	239	36.0	239	36.0	239	2	4.5	22.3	69.2	358	69.2	358			4	4.5	22.3
26.9	187	26.9	187	26.9	187	2	4.0	19.0	54.5	310	54.5	310			4	4.0	19.0
23.7	148	23.7	148	23.7	148	2	2.9	14.6	49.4	239	49.4	239			4	2.9	14.6
109.6	599	109.6	599			3	7.6	30.9	109.6	599	109.6	599			3	7.6	30.9
109.6	599	109.6	599			3	7.4	37.0	109.6	599	109.6	599			3	7.4	37.0
69.2	358	69.2	358			3	4.5	22.3	69.2	358	69.2	358			3	4.5	22.3
54.5	310	54.5	310			3	4.0	19.0	54.5	310	54.5	310			3	4.0	19.0
49.4	239	49.4	239			3	2.9	14.6	49.4	239	49.4	239			3	2.9	14.6
109.6	599	109.6	599			3	7.6	30.9	109.6	599	109.6	599			3	7.6	30.9
109.6	599	109.6	599			3	7.4	37.0	109.6	599	109.6	599			3	7.4	37.0
69.2	358	69.2	358			3	4.5	22.3	69.2	358	69.2	358			3	4.5	22.3
54.5	310	54.5	310			3	4.0	19.0	54.5	310	54.5	310			3	4.0	19.0
49.4	239	49.4	239			3	2.9	14.6	49.4	239	49.4	239			3	2.9	14.6

Electrical Data w/ Pumps - continued

CHILLER MODEL	VOLT	HZ	Pump Model	Pump	MINIMUM CIRCUIT AMPS	MIN N/F DISC SW	MIN DUAL ELEM FUSE & MIN CB	MAX DUAL ELEM FUSE & MAX CB
YLAA0115 YLAA0120 SE	200	60	D, M, N	41.7	553	800	600	600
	230	60		36.3	547	600	600	600
	380	60		22.0	343	400	400	400
	460	60		18.2	274	400	300	300
	575	60		14.5	242	400	300	300
YLAA0115 YLAA0120 SE	200	60	E, P	54.7	566	800	600	600
	230	60		49.5	560	800	600	600
	380	60		29.1	350	400	400	400
	460	60		24.8	280	400	300	300
	575	60		19.8	247	400	300	300
YLAA0115 YLAA0120 SE	200	60	K	15.4	527	600	600	600
	230	60		13.9	524	600	600	600
	380	60		8.1	329	400	350	350
	460	60		7.0	263	400	300	300
	575	60		5.6	233	400	250	250
YLAA0115 SE	200	60	L	27.1	539	600	600	600
	230	60		24.5	535	600	600	600
	380	60		14.8	336	400	400	400
	460	60		12.3	268	400	300	300
	575	60		9.8	237	400	250	250
YLAA0135 SE	200	60	F	21.4	604	800	700	700
	230	60		20.4	601	800	700	700
	380	60		12.0	378	600	400	400
	460	60		10.2	301	400	350	350
	575	60		8.2	265	400	300	300
YLAA0135 SE	200	60	C	32.2	615	800	700	700
	230	60		28.4	609	800	700	700
	380	60		15.4	382	600	400	450
	460	60		14.2	305	400	350	350
	575	60		11.4	268	400	300	300
YLAA0135 SE	200	60	D, M, N	41.7	624	800	700	700
	230	60		36.3	617	800	700	700
	380	60		22.0	388	600	450	450
	460	60		18.2	309	400	350	350
	575	60		14.5	271	400	300	300
YLAA0135 SE	200	60	E, R	54.7	637	800	700	700
	230	60		49.5	630	800	700	700
	380	60		29.1	395	600	450	450
	460	60		24.8	315	400	350	350
	575	60		19.8	277	400	300	300
YLAA0135 SE	200	60	K	15.4	598	800	700	700
	230	60		13.9	595	800	700	700
	380	60		8.1	374	600	400	400
	460	60		7.0	297	400	350	350
	575	60		5.6	262	400	300	300

Electrical Data w/ Pumps - continued

CHILLER MODEL	VOLT	HZ	Pump Model	Pump	MINIMUM CIRCUIT AMPS	MIN N/F DISC SW	MIN DUAL ELEM FUSE & MIN CB	MAX DUAL ELEM FUSE & MAX CB
YLAA0150 YLAA0155 SE	200	60	G	32.2	668	800	700	700
	230	60		28.4	663	800	700	700
	380	60		15.4	415	600	450	450
	460	60		14.2	332	400	350	350
	575	60		11.4	294	400	350	350
YLAA0150 YLAA0155 SE	200	60	H, L	27.1	663	800	700	700
	230	60		24.5	659	800	700	700
	380	60		14.8	414	600	450	450
	460	60		12.3	330	400	350	350
	575	60		9.8	292	400	350	350
YLAA0150 YLAA0155 SE	200	60	I, M	41.7	678	800	800	800
	230	60		36.3	671	800	700	700
	380	60		22.0	421	600	450	450
	460	60		18.2	336	400	350	350
	575	60		14.5	297	400	350	350
YLAA0150 YLAA0155 SE	200	60	J, R	54.7	691	800	800	800
	230	60		49.5	684	800	800	800
	380	60		29.1	428	600	450	450
	460	60		24.8	343	400	400	400
	575	60		19.8	302	400	350	350

SYSTEM # 1									SYSTEM # 2								
COMPR 1		COMPR 2		COMPR 3		COND FANS			COMPR 1		COMPR 2		COMPR 3		COND FANS		
RLA	LRA	RLA	LRA	RLA	LRA	QTY	FLA	LRA	RLA	LRA	RLA	LRA	RLA	LRA	QTY	FLA	LRA
109.6	599	109.6	599	109.6	599	4	7.6	30.9	109.6	599	109.6	599			4	7.6	30.9
109.6	599	109.6	599	109.6	599	4	7.4	37.0	109.6	599	109.6	599			4	7.4	37.0
69.2	358	69.2	358	69.2	358	4	4.5	22.3	69.2	358	69.2	358			4	4.5	22.3
54.5	310	54.5	310	54.5	310	4	4.0	19.0	54.5	310	54.5	310			4	4.0	19.0
49.4	239	49.4	239	49.4	239	4	2.9	14.6	49.4	239	49.4	239			4	2.9	14.6
109.6	599	109.6	599	109.6	599	4	7.6	30.9	109.6	599	109.6	599			4	7.6	30.9
109.6	599	109.6	599	109.6	599	4	7.4	37.0	109.6	599	109.6	599			4	7.4	37.0
69.2	358	69.2	358	69.2	358	4	4.5	22.3	69.2	358	69.2	358			4	4.5	22.3
54.5	310	54.5	310	54.5	310	4	4.0	19.0	54.5	310	54.5	310			4	4.0	19.0
49.4	239	49.4	239	49.4	239	4	2.9	14.6	49.4	239	49.4	239			4	2.9	14.6
109.6	599	109.6	599	109.6	599	4	7.6	30.9	109.6	599	109.6	599			4	7.6	30.9
109.6	599	109.6	599	109.6	599	4	7.4	37.0	109.6	599	109.6	599			4	7.4	37.0
69.2	358	69.2	358	69.2	358	4	4.5	22.3	69.2	358	69.2	358			4	4.5	22.3
54.5	310	54.5	310	54.5	310	4	4.0	19.0	54.5	310	54.5	310			4	4.0	19.0
49.4	239	49.4	239	49.4	239	4	2.9	14.6	49.4	239	49.4	239			4	2.9	14.6
109.6	599	109.6	599	109.6	599	4	7.6	30.9	109.6	599	109.6	599			4	7.6	30.9
109.6	599	109.6	599	109.6	599	4	7.4	37.0	109.6	599	109.6	599			4	7.4	37.0
69.2	358	69.2	358	69.2	358	4	4.5	22.3	69.2	358	69.2	358			4	4.5	22.3
54.5	310	54.5	310	54.5	310	4	4.0	19.0	54.5	310	54.5	310			4	4.0	19.0
49.4	239	49.4	239	49.4	239	4	2.9	14.6	49.4	239	49.4	239			4	2.9	14.6

Wiring Diagram

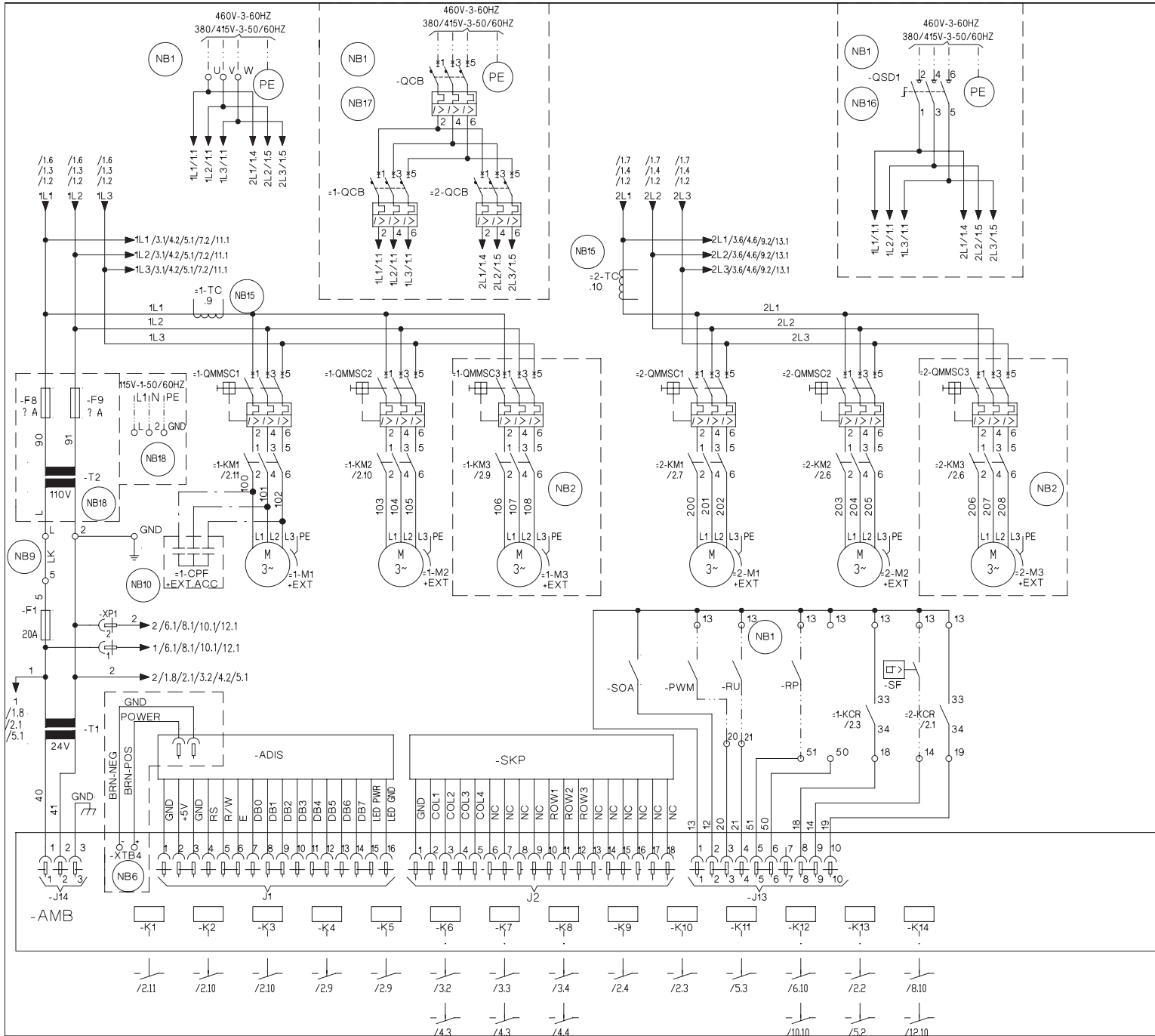

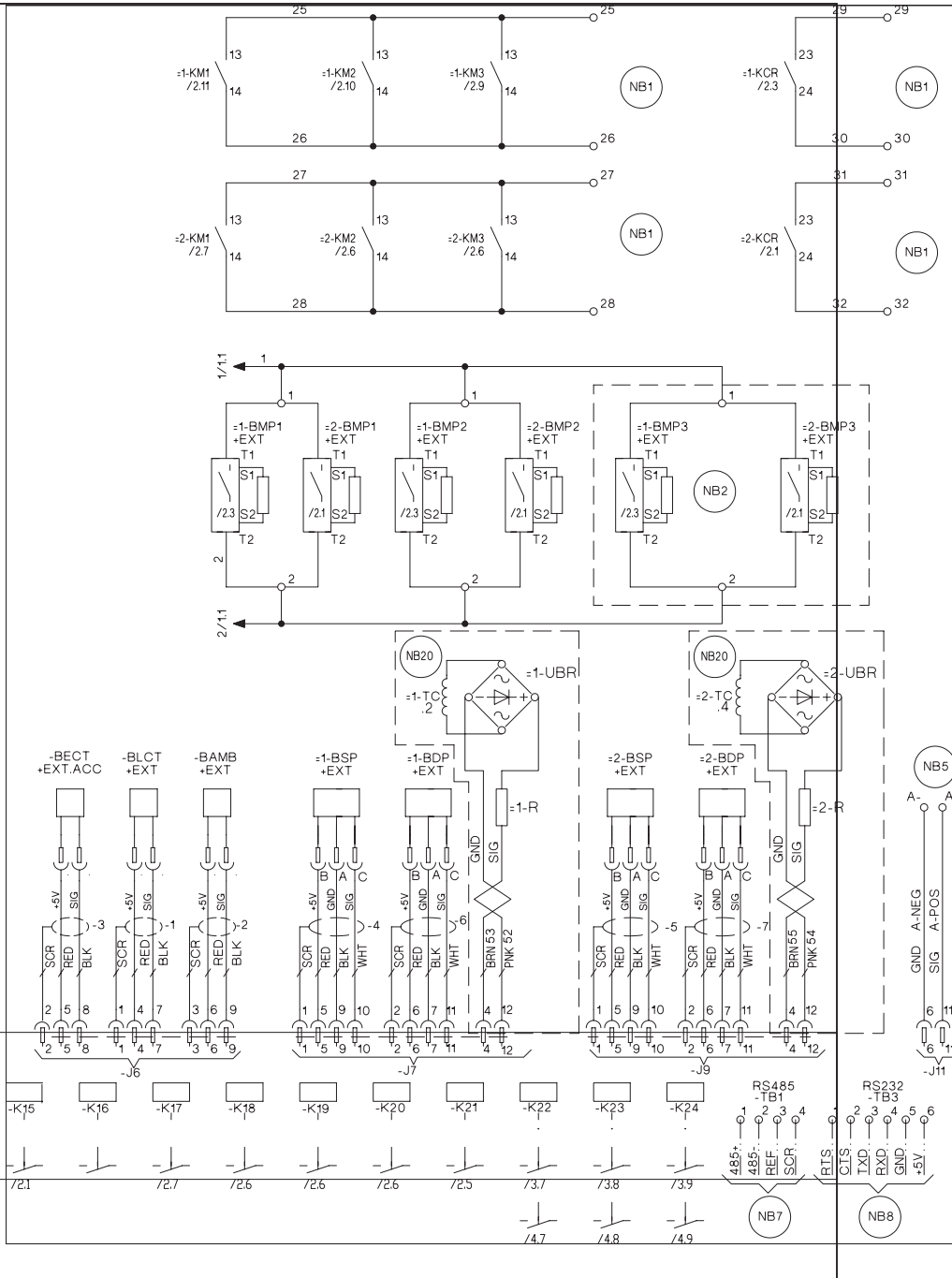

Elementary Wiring

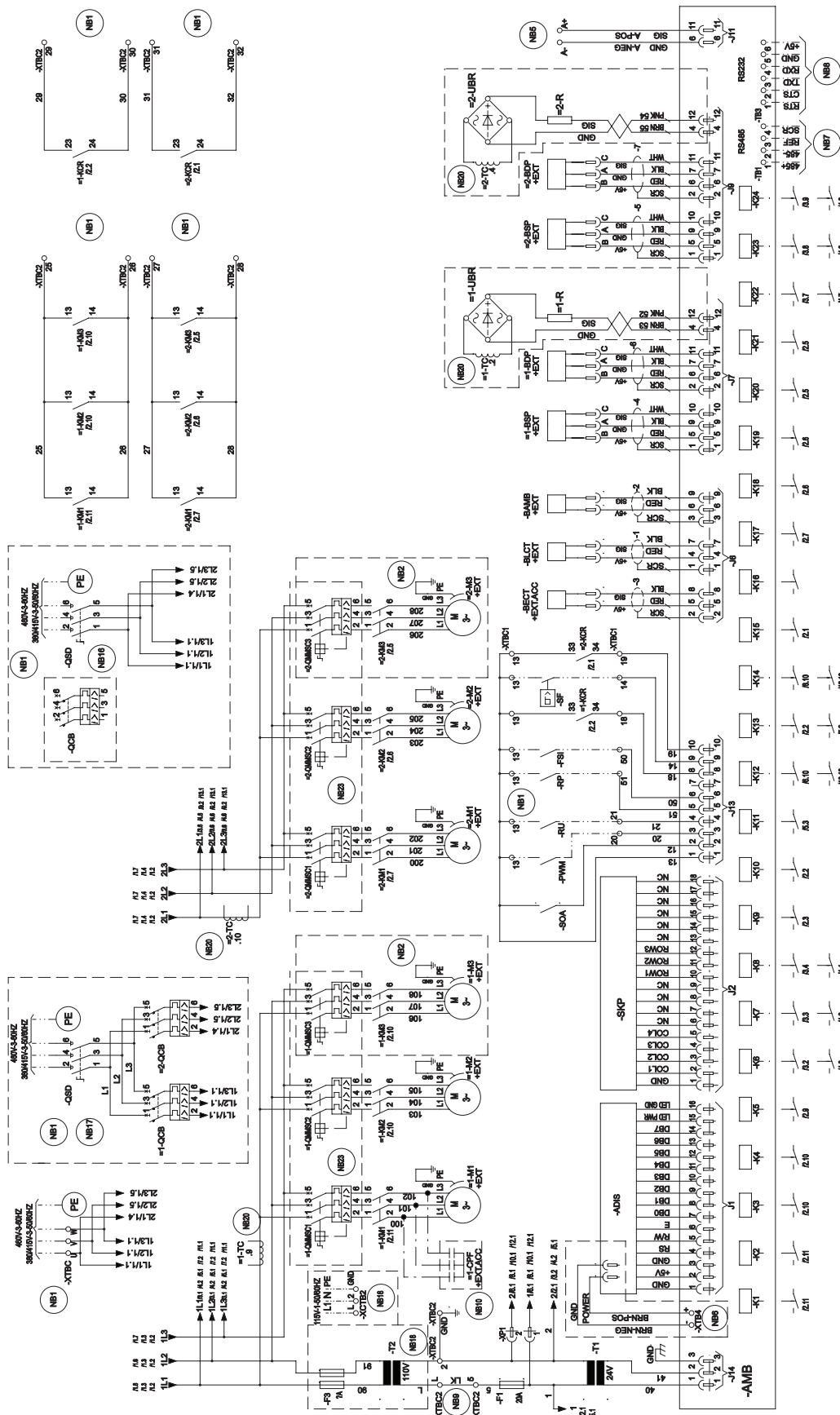

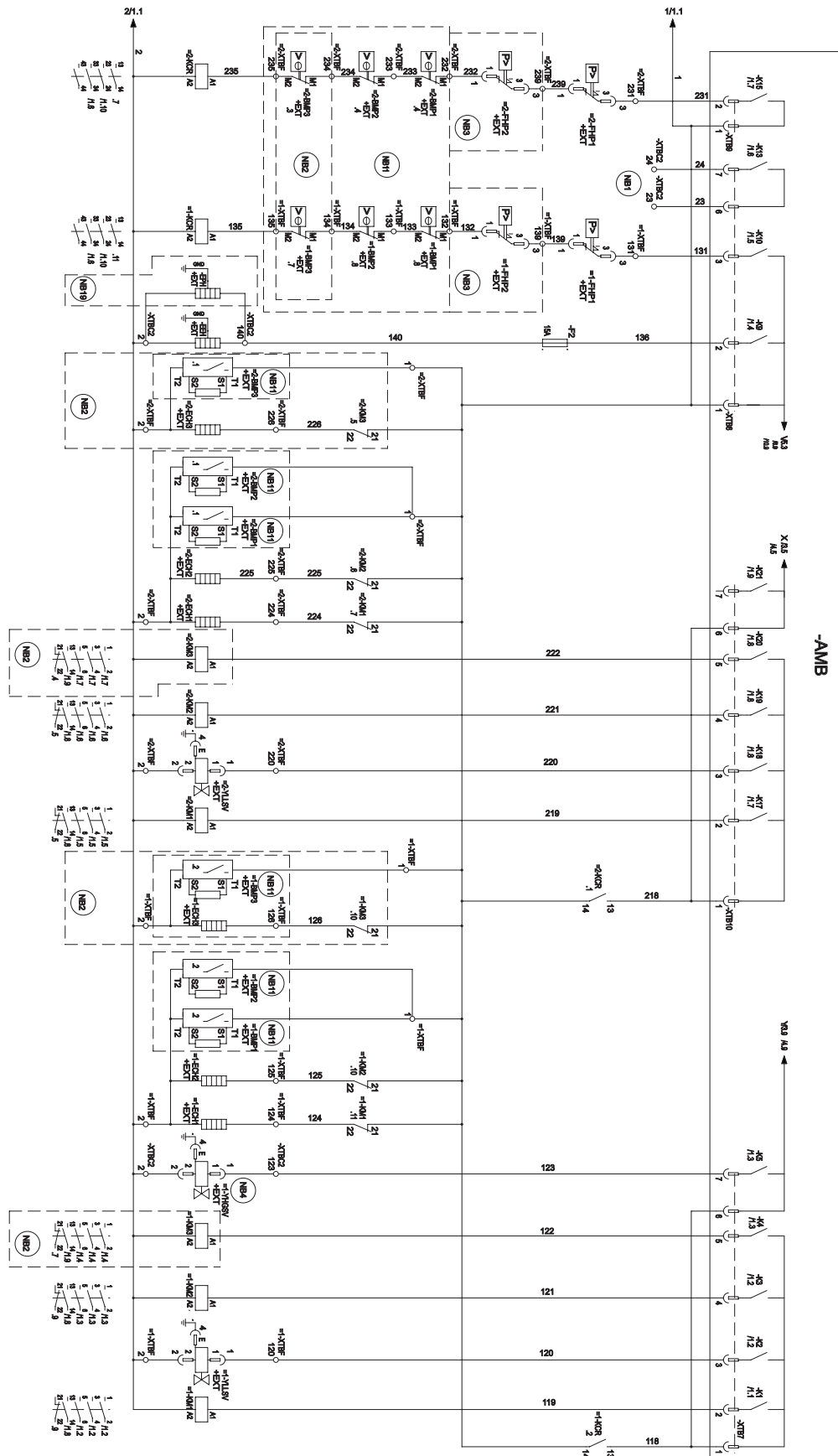

Condenser Fan Mapping and Sequencing

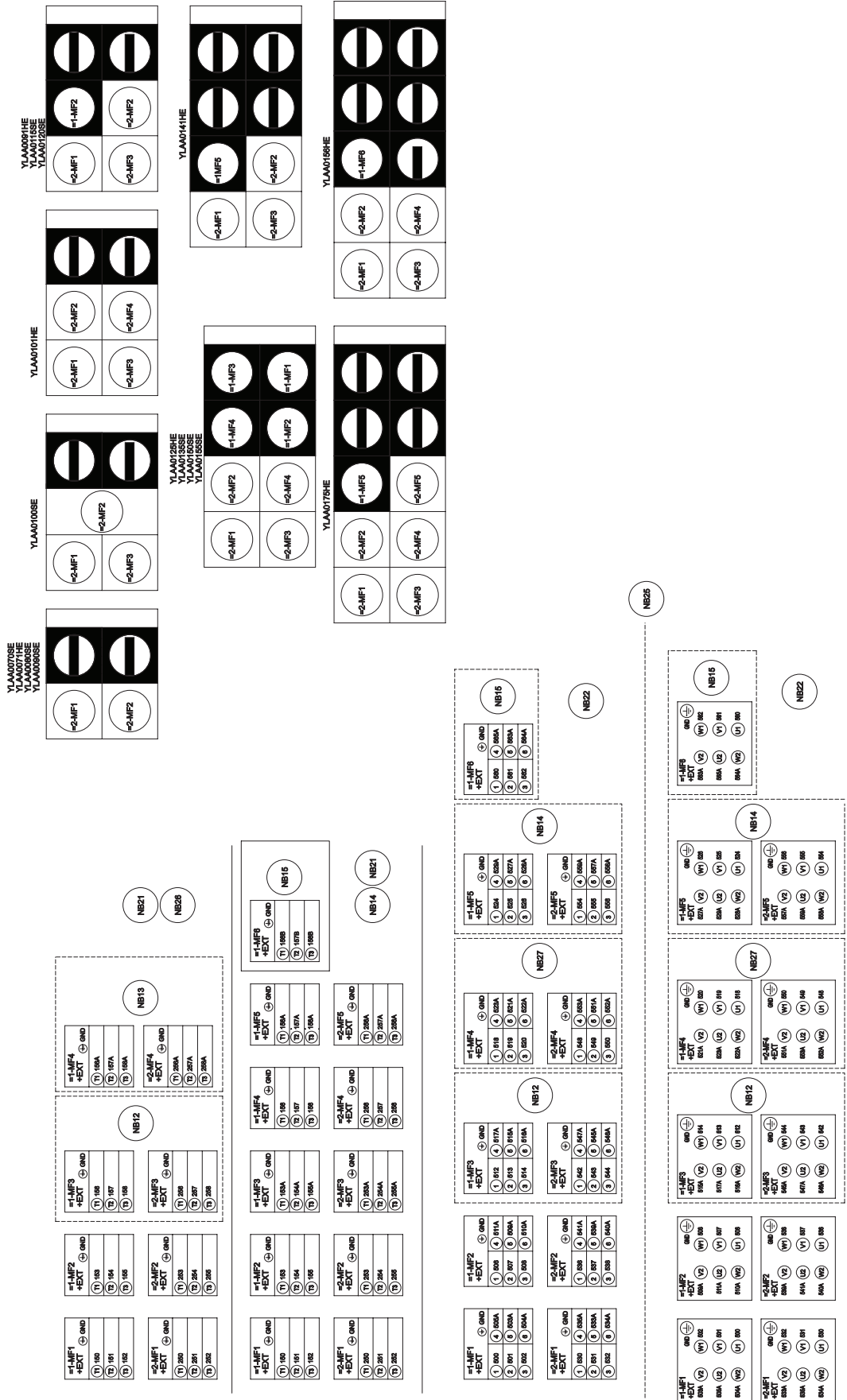

Compressor Wiring

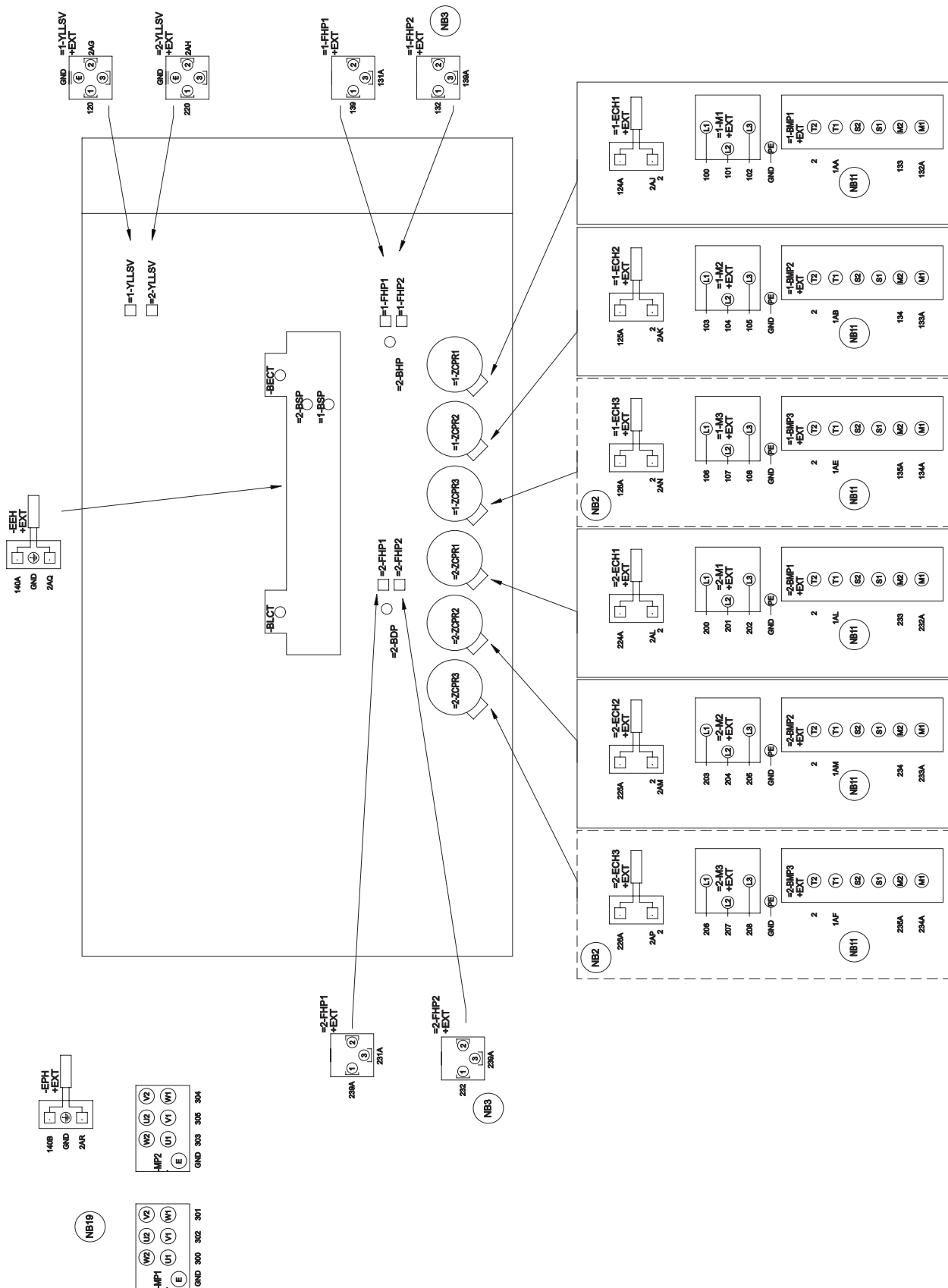

Power Options Connection Diagram

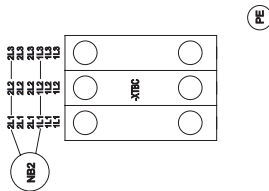
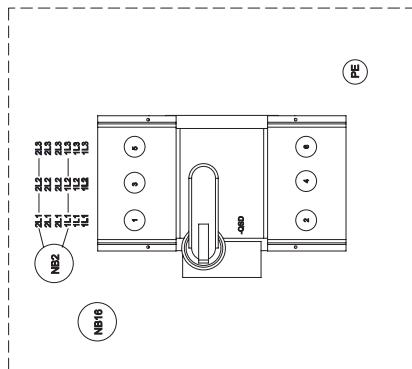
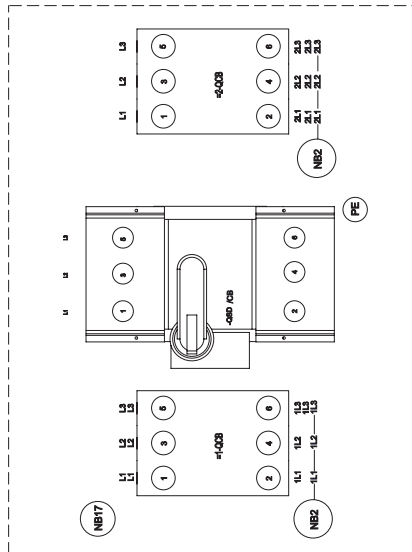
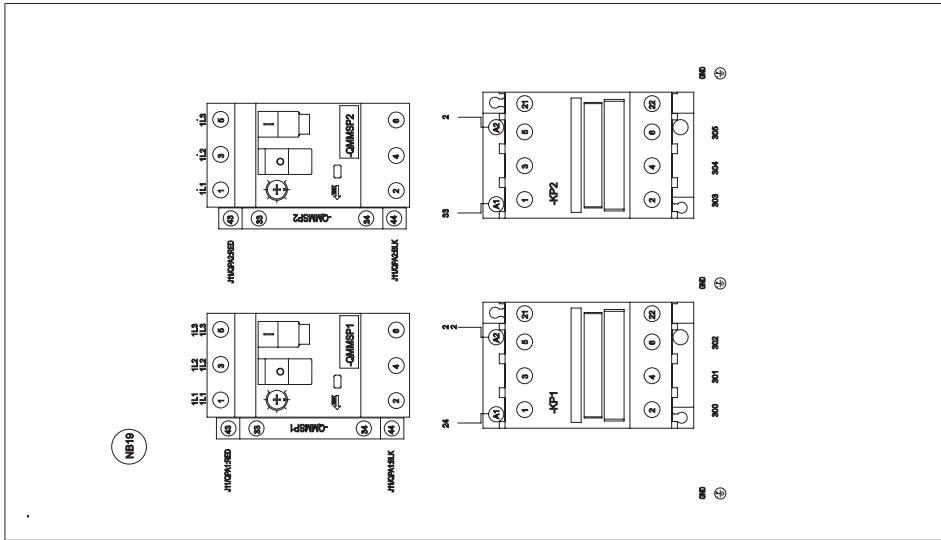

Power Panel

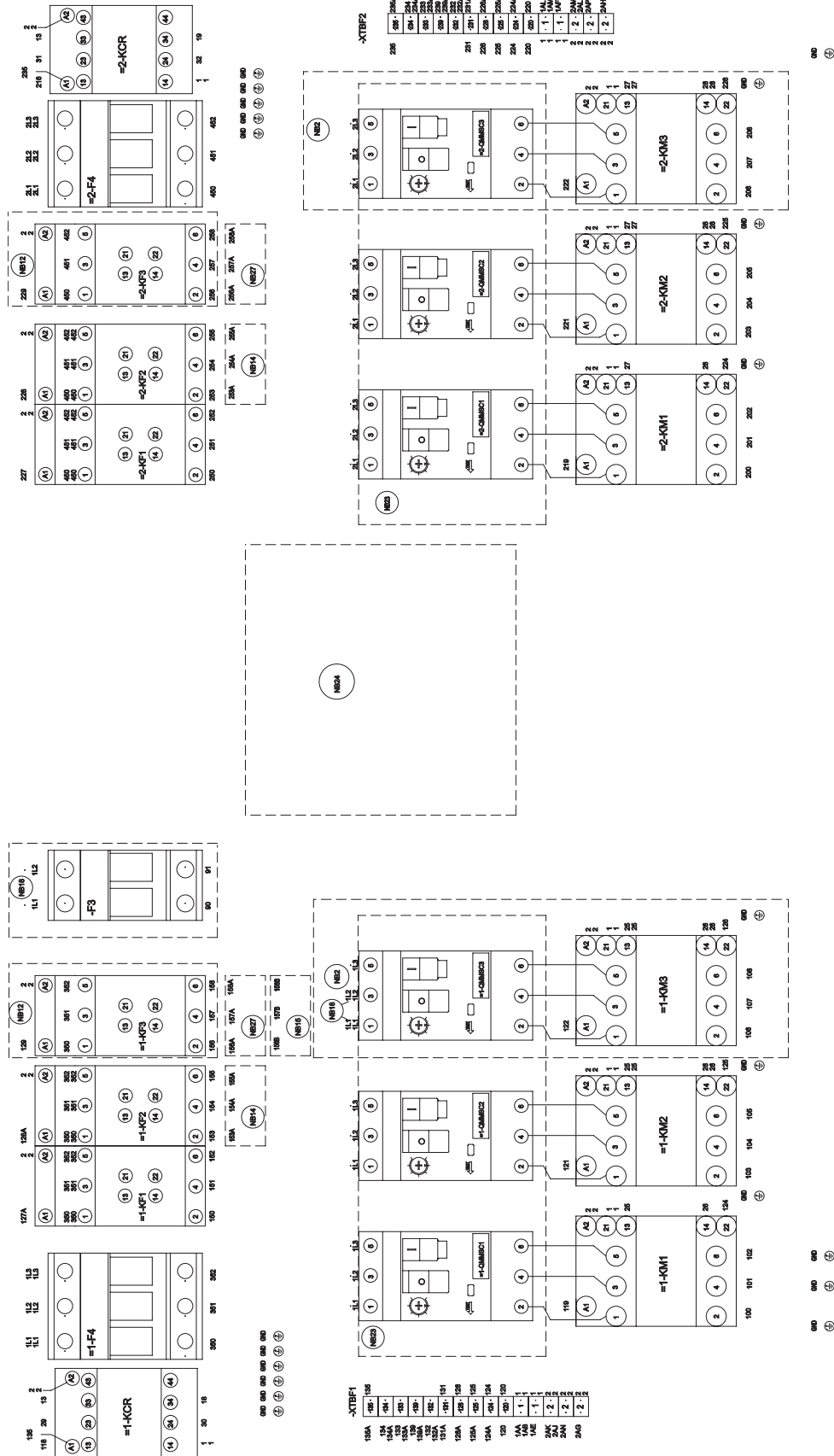

Dual Pump Wiring

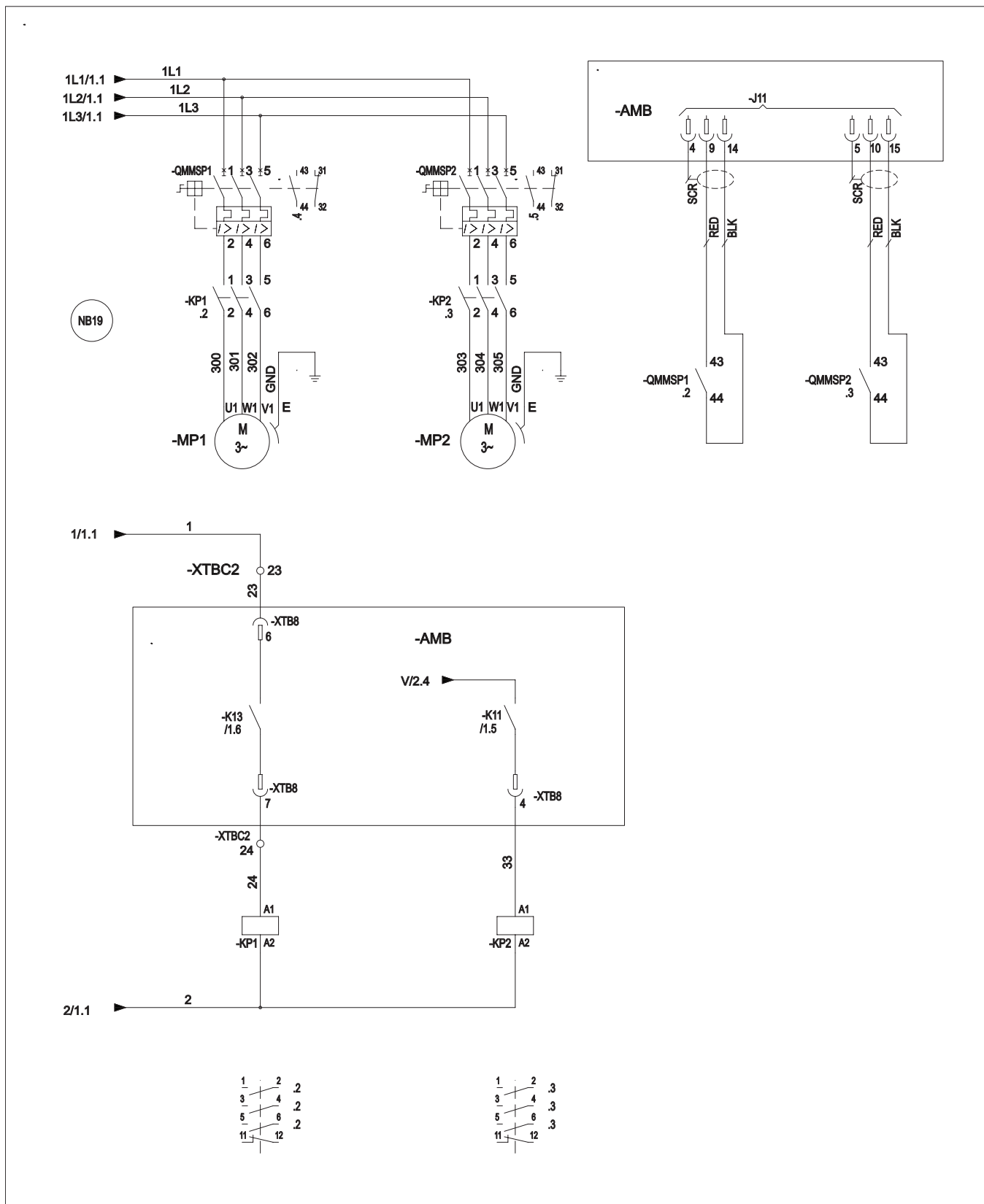

Wiring

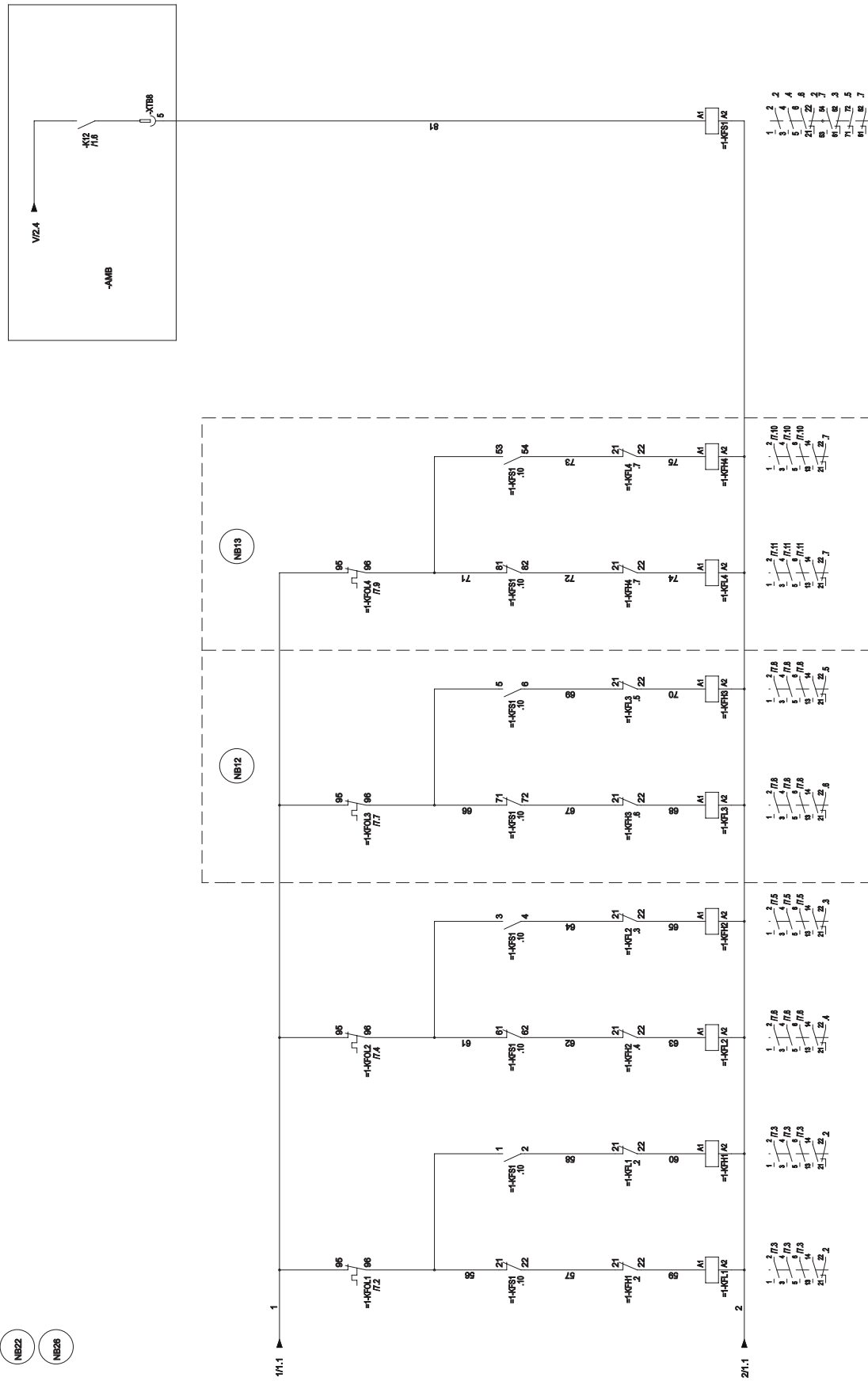

Notes

Designation	DESCRIPTION
ACC	ACCESSORY
- ADIS	DISPLAY BOARD
- AMB	MICRO BOARD

- BAMB	AMBIENT
- BDP	DISCHARGE PRESSURE
- BECT	ENTERING CHILLED TEMPERATURE
- BLCT	LEAVING CHILLED TEMPERATURE
	NOT FITTED ON REMOTE EVAP UNITS

- BMP	MOTOR PROTECTOR COMPRESSOR
- BSP	SUCTION PRESSURE

- CPF	CAPACITOR POWER FACTOR
-------	------------------------

- ECH	CRANKCASE HEATER
- EEH	EVAPORATOR HEATER
- EPH	PUMP HEATER
- EXT	EXTERNAL TO CONTROL PANEL

- F	FUSE
- FHP	HIGH PRESSURE CUTOFF
- FSI	FAN SPEED INHIBIT TWO SPEED FAN OPTION ONLY

GND	GROUND
G/Y	GREEN / YELLOW

J	PLUG BOARD CONNECTOR
---	----------------------

-K	CIRCUIT BOARD RELAY
-KF	FAN CONTACTOR LINE
-KFH	FAN CONTACTOR HIGH SPEED (INCLUDING COIL SUPPRESSOR)
-KFL	FAN CONTACTOR LOW SPEED (INCLUDING COIL SUPPRESSOR)
-KFOL	FAN OVERLOAD
-KFS	RELAY FAN SPEED
-KM	COMPRESSOR CONTACTOR (INCLUDING COIL SUPPRESSOR)
-KCR	CONTROL RELAY
-KP	PUMP CONTACTOR PART (INCLUDING COIL SUPPRESSOR)

- M	COMPRESSOR MOTOR
-MF	MOTOR FAN
-MP	MOTOR PUMP

NU	NOT USED
----	----------

PE	PROTECTIVE EARTH
PWM	PULSE WIDTH MODULATION TEMP RESET or REMOTE UNLOAD 2nd STEP

Designation	DESCRIPTION
- QCB	CIRCUIT BREAKER
- QMMS	MANUAL MOTOR STARTER COMPRESSOR
- QMMS	MANUAL MOTOR STARTER PUMP
- QSD	SWITCH DISCONNECT

R	RESISTOR
RED	RED
RP	RUN PERMISSIVE
RU	REMOTE UNLOAD 1st STEP

SCR	SCREEN
- SF	FLOW SWITCH
- SKP	KEYPAD
- SOA	SWITCH OFF AUTO

- T	TRANSFORMER
- TC	TRANSFORMER CURRENT

- UBR	BRIDGE RECTIFIER
-------	------------------

WHT	WHITE
-----	-------

- XTBC	TERMINAL BLOCK CUSTOMER
- XTBF	TERMINAL BLOCK FACTORY

- YHGSV	HOT GAS SOLENOID VALVE (INCLUDING COIL SUPPRESSOR)
- YLLSV	LIQUID LINE SOLENOID VALVE (INCLUDING COIL SUPPRESSOR) FIELD MOUNTED AND WIRED ON REMOTE EVAP UNITS

- ZCPR	COMPRESSOR
--------	------------

	NOTE WELL (SEE NOTE)
-------------------------------------------------------------------------------------	----------------------

- - - - -	WIRING AND ITEMS SHOWN THUS ARE STANDARD YORK ACCESSORIES
-----------	--------------------------------------------------------------

- · - · - · -	WIRING AND ITEMS SHOWN THUS ARE NOT SUPPLIED BY YORK
---------------	---------------------------------------------------------

— — — — —	ITEMS THUS ENCLOSED FORM A COMPONENTS OR SETS OF COMPONENTS
-----------	----------------------------------------------------------------

Notes - continued

GENERAL	
a.	THIS DRAWING IS BASED ON IEC SYMBOLS.
b.	FIELD WIRING TO BE IN ACCORDANCE WITH THE RELEVANT ELECTRICAL CODE AS WELL AS ALL OTHER APPLICABLE CODES AND SPECIFICATIONS
c.	ALL SOURCES OF SUPPLY SHOWN ON THIS DIAGRAM TO BE TAKEN FROM ONE MAIN ISOLATOR, NOT SHOWN OR SUPPLIED BY YORK.
d.	GREEN AND YELLOW WIRE IS USED FOR EARTH, MULTI-COLOURED CABLE USED FOR LOW VOLTAGE. RED WIRE USED FOR A.C. CONTROL, BLUE WIRE FOR NEUTRAL, BLACK WIRE FOR A.C. AND D.C. POWER. ORANGE WIRE SHOULD BE USED FOR INTERLOCK CONTROL WIRING SUPPLIED BY EXTERNAL SOURCE.
e.	LEGEND DESIGNATION DEPICTS COMPONENT ABBREVIATIONS. NUMBER PREFIX LOCATED, IF APPLICABLE, ON SCHEMATIC CIRCUIT, REFERS TO SYSTEM THEREON, E.G.= 1-FHP2 REFERS TO HIGH PRESSURE CUTOOUT NO 2 ON SYSTEM NO 1.
f.	ALL WIRING TO CONTROL SECTION VOLTAGE FREE CONTACTS REQUIRES A SUPPLY PROVIDED BY THE CUSTOMER MAXIMUM VOLTAGE 240 VOLTS. THE CUSTOMER MUST TAKE PARTICULAR CARE WHEN DERIVING THE SUPPLIES FOR THE VOLTAGE FREE TERMINALS WITH REGARD TO A COMMON POINT OF ISOLATION. THUS, THESE CIRCUITS WHEN USED MUST BE FED VIA THE COMMON POINT OF ISOLATION THE VOLTAGE TO THESE CIRCUITS IS REMOVED WHEN THE COMMON POINT OF ISOLATION TO THE UNIT IS OPENED. THIS COMMON POINT OF ISOLATION IS NOT SUPPLIED BY YORK. THE YORK VOLTAGE FREE CONTACTS ARE RATED AT 100VA. ALL INDUCTIVE DEVICES {RELAYS} SWITCH BY THE YORK VOLTAGE FREE CONTACTS MUST HAVE THEIR COIL SUPPRESSED USING STANDARD R/C SUPPRESSORS.
g.	CUSTOMER VOLTAGE FREE CONTACTS CONNECTED TO TERMINAL 13 MUST BE RATED AT 30V 5ma
h.	NO CONTROLS {RELAYS ETC.} SHOULD BE MOUNTED IN ANY SECTION OF THE CONTROL PANEL. ADDITIONALLY, CONTROL WIRING NOT CONNECTED TO THE YORK CONTROL PANEL SHOULD NOT BE RUN THROUGH THE PANEL. IF THESE PRECAUTIONS ARE NOT FOLLOWED, ELECTRICAL NOISE COULD CAUSE MALFUNCTIONS OR DAMAGE TO THE UNIT AND ITS CONTROLS.
NOTES	
1	REFER TO INSTALATION COMMISIONING OPERATION AND MAINTENANCE MANUAL FOR CUSTOMER CONNECTIONS AND CUSTOMER CONNECTION NOTES, NON COMPLIANCE TO THESE INSTRUCTIONS WILL INVALIDATE UNIT WARRANTY.
2	WIRING AND COMPONENTS FOR COMPRESSOR 3 ONLY FITTED WHEN UNIT HAS 3 COMPRESSORS ON THE SYSTEM. 1-BMP3 IS REPLACED BY A LINK ACROSS TERMINALS 134 & 135. 2-BMP3 IS REPLACED BY A LINK ACROSS TERMINALS 234 & 235.
3	FHP2 IS ONLY FITTED ON CE YLAA ??? AND ABOVE. WHEN NOT FITTED 1-FHP2 IS REPLACED BY A LINK ACROSS TERMINALS 132 & 139. 2-FHP2 IS REPLACED BY A LINK ACROSS TERMINALS 232 & 239
4	FITTED ON UNITS WITH HOT GAS BYPASS OPTION.
5	EMS OPTION IS WIRED AS SHOWN
6	THIS WIRING MUST BE USED FOR OLD DISPLAY 031-0110-000
7	NETWORK CONNECTION POINT
8	PRINTER PORT
9	REMOTE EMERGENCY STOP CAN BE WIRED BETWEEN TERMINAL L AND 5 AFTER REMOVING LINK
10	POWER FACTOR CORRECTION ACCESSORY. POWER FACTOR CORRECTION FITTED TO EACH COMPRESSOR CONTACTOR
11	NOT FITTED ON COMPRESSORS WITH INTERNAL MOTOR PROTECTION. FOR SYTEM 1 TERMINALS 132 & 133, 133 & 134 AND 134 & 135 ARE LINKED. FOR SYTEM 2 TERMINALS 232 & 233, 233 & 234 AND 234 & 235 ARE LINKED.
12	ONLY FITTED ON SYSTEMS WITH 3 OR 4 FANS
13	ONLY FITTED ON SYSTEMS WITH 4 FANS
14	ONLY FITTED ON SYSTEMS WITH 5 FANS
15	ONLY FITTED ON SYSTEMS WITH 6 FANS
16	INPUT SWITCH DISCONNECT(STANDARD ON CE UNITS) OR CIRCUIT BREAKER OPTION REPLACES INPUT TERMINAL BLOCK
17	INPUT SWITCH DISCONNECT & SYSTEM CIRCUIT BREAKER OPTION REPLACES INPUT TERMINAL BLOCK
18	115V CONTROL CIRCIUT REQUIRES A 115V SUPPLY UNLESS CONTROL CIRCUIT TRANSFORMER -T2 & -F3 ARE FITTED (STANDARD ON CE UNITS)
19	FOR OPTIONAL HYDRO KIT. HEATER -EPH IS FITTED AND WIRED AS SHOWN. ON SINLGE PUMP -KP1, -QMMSP1 & -MP1 ARE FITTED & WIRED AS SHOWN. ON TWO PUMP HYDRO KITS -KP2, -QMMSP2 & -MP2 ARE ALSO FITTED AND WIRED AS SHOWN.
20	CURRENT MEASUREMENT OPTION WIRED AS SHOW
21	ONLY FITTED ON SYSTEMS WITH SINGLE SPEED FANS
22	ONLY FITTED ON SYSTEMS WITH TWO SPEED FANS
23	OPTIONAL COMPRESSOR MANUAL MOTORS STARTERS (STANDARD ON CE UNITS)
24	SEE SHEET 3 OF CONNECTION DIAGRAM FOR POWER INPUT OPTIONS
25	ALTERNATE CONNECTIONS SHOWN FOR DIFFERENT TWO SPEED MOTOR TYPES
26	ONLY FITTED ON SYSTEMS WITH A MAXIMUM OF 4 FANS

Application Data

UNIT LOCATION

The YLAA chillers are designed for outdoor installation. When selecting a site for installation, be guided by the following conditions:

1. For outdoor locations of the unit, select a place having an adequate supply of fresh air for the condenser.
2. Avoid locations beneath windows or between structures where normal operating sounds may be objectionable.
3. Installation sites may be either on a roof, or at ground level. (See FOUNDATION.)
4. The condenser fans are the propeller-type, and are not recommended for use with duct work in the condenser air stream.
5. When it is desirable to surround the unit(s), it is recommended that the screening be able to pass the required chiller CFM without exceeding 0.1" of water external static pressure.
6. Protection against corrosive environments is available by supplying the units with either copper fin, cured phenolic, or epoxy coating on the condenser coils. The phenolic or epoxy coils should be offered with any units being installed at the seashore or where salt spray may hit the unit.

In installations where winter operation is intended and snow accumulations are expected, additional height must be provided to ensure normal condenser air flow.

Recommended clearances for units are given in DIMENSIONS. When the available space is less, the unit(s) must be equipped with the discharge pressure transducer option to permit high pressure unloading in the event that air recirculation were to occur.

FOUNDATION

The unit should be mounted on a flat and level foundation, ground or roof, capable of supporting the entire operating weight of the equipment. Operating weights are given in the PHYSICAL DATA tables.

ROOF LOCATIONS – Choose a spot with adequate structural strength to safely support the entire weight of the unit and service personnel. Care must be taken not to damage

the roof during installation. If the roof is “bonded”, consult the building contractor or architect for special installation requirements. Roof installations should incorporate the use of spring-type isolators to minimize the transmission of vibration into the building structure.

GROUND LEVEL INSTALLATIONS – It is important that the units be installed on a substantial base that will not settle, causing strain on the liquid lines and resulting in possible leaks. A one-piece concrete slab with footers extending below the frost line is highly recommended. Additionally, the slab should not be tied to the main building foundation as noises will telegraph.

Mounting holes (5/8" diameter) are provided in the steel channel for bolting the unit to its foundation. See DIMENSIONS.

For ground level installations, precautions should be taken to protect the unit from tampering by or injury to unauthorized persons. Screws on access panels will prevent casual tampering; however, further safety precautions, such as unit enclosure options, a fenced-in enclosure, or locking devices on the panels may be advisable. Check local authorities for safety regulations.

CHILLED LIQUID PIPING

The chilled liquid piping system should be laid out so that the circulating pump discharges into the evaporator. The inlet and outlet evaporator liquid connections are given in DIMENSIONS.

Hand stop valves are recommended for use in all lines to facilitate servicing. Drain connections should be provided at all low points to permit complete drainage of the evaporator and system piping. Additionally, a strainer (40 mesh) is recommended for use on the INLET line to the evaporator.

Pressure gauge connections are recommended for installation in the inlet and outlet water lines. Gauges are not furnished with the unit and are to be furnished by other suppliers.

The chilled liquid lines that are exposed to outdoor ambients should be wrapped with a supplemental heater cable and covered with insulation. As an alternative, ethylene glycol should be added to protect against freeze-up during low ambient periods.

A flow switch is available as an accessory on all units. The flow switch (or its equivalent) must be installed in the leaving water piping of the evaporator and must not be used to start and stop the unit.

Guide Specifications

PART 1 – GENERAL .

1.01 SCOPE

- A. The requirements of the General Conditions, Supplementary Conditions, Division 1, and Drawings apply to all Work herein.
- B. Provide Microprocessor controlled, multiple-scroll compressor, air-cooled, liquid chillers of the scheduled capacities as shown and indicated on the Drawings, including but not limited to:
 - 1. Chiller package with ZERO Ozone Depletion Potential Refrigerant R-410A
 - 2. Electrical power and control connections
 - 3. Chilled water connections
 - 4. Factory Start-Up
 - 5. Charge of refrigerant and oil.

1.02 QUALITY ASSURANCE

- A. Products shall be Designed, Tested, Rated and Certified in accordance with, and installed in compliance with applicable sections of the following Standards and Codes:
 - 1. ANSI/ASHRAE Standard 15 – *Safety Code for Mechanical Refrigeration*
 - 2. ASHRAE 90.1– *Energy Efficiency compliance.*
 - 3. ANSI/NFPA Standard 70 – *National Electrical Code (N.E.C.).*
 - 4. *ASME Boiler & Pressure Vessel Code, Section VIII, Division 1.*
 - 5. ARI Standard 550/590 – *Positive Displacement Compressors and Air Cooled Rotary Screw Water-Chilling Packages.*
 - 6. Conform to Intertek Testing Services, formerly ETL, for construction of chillers and provide ETL/cETL Listing label.
 - 7. Manufactured in facility registered to ISO 9002.
 - 8. OSHA – Occupational Safety and Health Act
- B. Factory Test: Chiller shall be pressure-tested, evacuated and fully charged with refrigerant and oil, and shall be factory operational run tested with water flowing through the vessel.
- C. Chiller manufacturer shall have a factory trained and supported service organization that is within a 50 mile radius of the site.
- D. Warranty: Manufacturer shall warrant all equipment and material of its manufacture against defects in workmanship and material for a period of one year from date of initial start-up or eighteen (18) months from date of shipment, whichever occurs first.

1.03 DELIVERY AND HANDLING

- A. Unit shall be delivered to job site fully assembled and charged with refrigerant and oil by the Manufacturer.
- B. Unit shall be stored and handled per Manufacturer's instructions.
- C. Protect the chiller and its accessories from the weather and dirt exposure during shipment.
- D. During shipment, provide protective covering over vulnerable components. Fit nozzles and open ends with plastic enclosures.

PART 2 - PRODUCTS

2.01 CHILLER MATERIALS AND COMPONENTS

- A. General: Install and commission, as shown on the schedules and plans, factory assembled, charged, and tested air cooled scroll compressor chiller(s) as specified herein. Chiller shall be designed, selected, and constructed using a refrigerant with Flammability rating of "1", as defined by ANSI/ASHRAE STANDARD - 34 *Number Designation and Safety Classification of Refrigerants*. Chiller shall include not less than two refrigerant circuits above 35 tons (123kW), scroll compressors, direct-expansion-type evaporator, air-cooled condenser, refrigerant, lubrication system, interconnecting wiring, safety and operating controls including capacity controller, control center, motor starting components, and special features as specified herein or required for safe, automatic operation.
- B. Cabinet: External structural members shall be constructed of heavy gauge, galvanized steel coated with baked on powder paint which, when subject to ASTM B117, 1000 hour, 5% salt spray test, yields minimum ASTM 1654 rating of "6".
- C. Service Isolation valves: Service discharge (ball type) isolation valves are added to unit per system. This includes a system high-pressure relief valve in compliance with ASHRAE 15.
- D. Pressure Transducers and Readout Capability
 - 1. Discharge Pressure Transducers: Permits unit to sense and display discharge pressure.
 - 2. Suction Pressure Transducers: Permits unit to sense and display suction pressure.
 - 3. High Ambient Control: Allows units to operate when the ambient temperature is above 115°F (46°C). Includes discharge pressure transducers.

2.02 COMPRESSORS

Compressors: Shall be hermetic, scroll-type, including:

1. Compliant design for axial and radial sealing
2. Refrigerant flow through the compressor with 100% suction cooled motor.
3. Large suction side free volume and oil sump to provide liquid handling capability.
4. Compressor crankcase heaters to provide extra liquid migration protection.
5. Annular discharge check valve and reverse vent assembly to provide low-pressure drop, silent shutdown and reverse rotation protection.
6. Initial oil charge.
7. Oil level sightglass.
8. Vibration isolator mounts for compressors.
9. Brazed-type connections for fully hermetic refrigerant circuits.
10. Compressor Motor overloads capable of monitoring compressor motor current. Provides extra protection against compressor reverse rotation, phase-loss and phase-imbalance

2.03 REFRIGERANT CIRCUIT COMPONENTS

Each refrigerant circuit shall include: a discharge service ball type isolation valve, high side pressure relief, liquid line shutoff valve with charging port, low side pressure relief device, filter-drier, solenoid valve, sight glass with moisture indicator, thermostatic expansion valves, and flexible, closed-cell foam insulated suction line and suction pressure transducer.

2.04 HEAT EXCHANGERS

A. Evaporator: **YLAA**

1. Direct expansion type with refrigerant inside high efficiency copper tubes, chilled liquid forced over the tubes by brass baffles.
2. Constructed, tested, and stamped in accordance with applicable sections of ASME pressure vessel code for minimum 450 psig (3103 kPa) refrigerant side design working pressure and 150 PSIG (1034 kPa) water side design working pressure.
3. Shell covered with 3.4" (19mm), flexible, closed cell insulation, thermal conductivity of 0.26k ([BTU/HR-Ft² -°F]/in.) maximum. Water nozzles with grooves for mechanical couplings, and insulated by Contractor after pipe installation.
4. Provide vent and drain fittings, and thermostatically controlled heaters to protect to -20°F (-29°C) ambient in off-cycle.

B. Air Cooled Condenser:

1. Coils: Condenser coils are made of a single material to avoid galvanic corrosion due to dissimilar metals. Coils and headers are brazed as one piece. Integral sub cooling is included. The design working pressure of the coil is 650 PSIG (45 bar). Condenser coil shall be pressure washable up to 1500 psi washer.
2. Low Sound Fans: Shall be dynamically and statically balanced, direct drive, corrosion resistant glass fiber reinforced composite blades molded into a low noise, full-airfoil cross section, providing vertical air discharge and low sound. Each fan in its own compartment to prevent crossflow during fan cycling. Guards of heavy gauge, PVC (polyvinylchloride) coated or galvanized steel.
3. Fan Motors: High efficiency, direct drive, 6 pole, 3 phase, insulation class "F", current protected, Totally Enclosed Air-Over (TEAO), rigid mounted, with double sealed, permanently lubricated, ball bearings.

2.05 CONTROLS

A. General: Automatic start, stop, operating, and protection sequences across the range of scheduled conditions and transients.

B. Microprocessor Enclosure: Rain and dust tight NEMA 3R/12 powder painted steel cabinet with hinged, latched, and gasket sealed door.

C. Microprocessor Control Center:

1. Automatic control of compressor start/stop, anti-coincidence and anti-recycle timers, automatic pumpdown shutdown, condenser fans, evaporator pump, evaporator heater, unit alarm contacts, and chiller operation from 0°F to 125°F (-18°C to 52°C) ambient. Automatic reset to normal chiller operation after power failure.
2. Remote water temperature reset via 0-10 VDC or 4-20 mA input signal or up to two steps of demand (load) limiting.
3. Software stored in non-volatile memory, with programmed setpoints retained in lithium battery backed real-time-clock (RTC) memory for minimum 5 years.
4. Forty character liquid crystal display, descriptions in English (or Spanish, French, Italian, or German), numeric data in English (or Metric) units. Sealed keypad with sections for Setpoints, Display/Print, Entry, Unit Options & clock, and On/Off Switch.
5. Programmable Setpoints (within Manufacturer limits): display language; chilled liquid temperature

Guide Specifications - continued

setpoint and range, remote reset temperature range, set daily schedule/holiday for start/stop, manual override for servicing, low and high ambient cutouts, number of compressors, low liquid temperature cutout, low suction pressure cutout, high discharge pressure cutout, anti-recycle timer (compressor start cycle time), and anti-coincident timer (delay compressor starts).

6. Display Data: Return and leaving liquid temperatures, low leaving liquid temperature cutout setting, low ambient temperature cutout setting, outdoor air temperature, English or metric data, suction pressure cutout setting, each system suction pressure, discharge pressure (optional), liquid temperature reset via a Johnson Controls ISN DDC or Building Automation System (by others) via a 4-20milliamp or 0-10 VDC input, anti-recycle timer status for each compressor, anti-coincident system start timer condition, compressor run status, no cooling load condition, day, date and time, daily start/stop times, holiday status, automatic or manual system lead/lag control, lead system definition, compressor starts/operating hours (each), status of hot gas valves, evaporator heater and fan operation, run permissive status, number of compressors running, liquid solenoid valve status, load & unload timer status, water pump status.
7. System Safeties: Shall cause individual compressor systems to perform auto shut down; manual reset required after the third trip in 90 minutes. Includes: high discharge pressure, low suction pressure, high pressure switch, and motor protector. Compressor motor protector shall protect against damage due to high input current or thermal overload of windings.
8. Unit Safeties: Shall be automatic reset and cause compressors to shut down if low ambient, low leaving chilled liquid temperature, under voltage, and flow switch operation. Contractor shall provide flow switch and wiring per chiller manufacturer requirements.
9. Alarm Contacts: Low ambient, low leaving chilled liquid temperature, low voltage, low battery, and (per compressor circuit): high discharge pressure, and low suction pressure.

D. Manufacturer shall provide any controls not listed above, necessary for automatic chiller operation. Mechanical Contractor shall provide field control wiring necessary to interface sensors to the chiller control system.

2.06 POWER CONNECTION AND DISTRIBUTION

A. Power Panels:

1. NEMA 3R/12 rain/dust tight, powder painted steel cabinets with hinged, latched, and gasket sealed outer doors. Provide main power connection(s), control power connections, compressor and fan motor start contactors, current overloads, and factory wiring.
2. Power supply shall enter unit at a single location, be 3 phase of scheduled voltage, and connect to individual terminal blocks per compressor. Separate disconnecting means and/or external branch circuit protection (by Contractor) required per applicable local or national codes.

B. Compressor, control and fan motor power wiring shall be located in an enclosed panel or routed through liquid tight conduit.

2.07 ACCESSORIES AND OPTIONS

Some accessories and options supercede standard product features. Your Johnson Controls representative will be pleased to provide assistance.

- A. Microprocessor controlled, Factory installed Across-the-Line type compressor motor starters as standard.
- B. Outdoor Ambient Temperature Control
 1. Low Ambient Control: Permits unit operation to 0°F ambient. Standard unit controls to 30°F ambient.
 2. High Ambient Control: Permits unit operation above 115°F ambient.
- C. Power Supply Connections:
 1. Single Point Power Supply: Single point Terminal Block for field connection and interconnecting wiring to the compressors. Separate external protection must be supplied, by others, in the incoming power wiring, which must comply with the National Electric Code and/or local codes.
 2. Single Point or Multiple Point Disconnect: Single or Dual point Non-Fused Disconnect(s) and lockable external handle (in compliance with Article 440-14 of N.E.C.) can be supplied to isolate the unit power voltage for servicing. Separate external fusing must be supplied, by others, in the incoming power wiring, which must comply with the National Electric Code and/or local codes.
 3. Single Point Circuit Breaker: Single point Terminal Block with Circuit Breaker and lockable external handle (in compliance with Article 440-14 of N.E.C.) can be supplied to isolate power voltage

for servicing. Incoming power wiring must comply with the National Electric Code and/or local codes.

- E. Control Power Transformer: Converts unit power voltage to 120-1-60 (500 VA capacity). Factory-mounting includes primary and secondary wiring between the transformer and the control panel.
- F. Power Factor Correction Capacitors: Provided to correct unit compressor factors to a 0.90-0.95.
- G. Condenser Coil Environmental Protection:
 - 1. Post-Coated Dipped: Dipped-cured coating on condenser coils for seashore and other corrosive applications (with the exception of strong alkalis, oxidizers, and wet bromine, chlorine and fluorine in concentrations greater than 100 ppm).
- H. Protective Chiller Panels (Factory or Field Mounted)
 - 1. Louvered Panels (condenser coils only): Painted steel as per remainder of unit cabinet, over external condenser coil faces.
 - 2. Wire Panels (full unit): Heavy gauge, welded wire-mesh, coated to resist corrosion, to protect condenser coils from incidental damage and restrict unauthorized access to internal components.
 - 3. Louvered Panels (full unit): Painted steel as per remainder of unit cabinet, to protect condenser coils from incidental damage, visually screen internal components, and prevent unauthorized access to internal components.
 - 4. Louvered/Wire Panels: Louvered steel panels on external condenser coils painted as per remainder of unit cabinet. Heavy gauge, welded wire-mesh, coated to resist corrosion, around base of machine to restrict unauthorized access.
 - 5. End Louver (hail huard): Louvered steel panels on external condenser coil faces located at the ends of the chiller.
- I. Flow Switch (Field-mounted): Vapor proof SPDT, NEMA 4X switch (___ 150 PSIG or ___ 300 PSIG), -20°F to 250°F.
- J. Differential Pressure Switch: Alternative to an above mentioned flow switch. Pretempco model DPS300A-P40PF-82582-5 (300 psi max. working pressure) SPDT 5 amp 125/250VAC switch, Range 3 - 40 PSID, deadband 0.5 - 0.8 psi, with 1/4" NPTE Pressure Connections.
- K. Evaporator options:
 - 1. Provide 1-1/2" evaporator insulation in lieu of standard 3/4".
 - 2. Provide Raised Face Flanges for field installation on evaporator nozzles and field piping:
 - a. 150 PSIG, welded Flanges.
- L. Hot Gas By-Pass: Permits continuous, stable operation at capacities below the minimum step of unloading to as low as 5% capacity (depending on both the unit & operating conditions) by introducing an artificial load on the evaporator. Hot gas by-pass is installed on only one refrigerant circuit.
- M. Thermal Storage: Leaving chilled liquid setpoint range for charge cycle from 25°F to 20°F minimum, with automatic reset of the leaving brine temperature up to 40°F above the setpoint.
- N. Low Temperature Process Brine: Leaving chilled liquid setpoint range 20°F to 50°F.
- O. Chicago Code Relief Valves to meet Chicago Code requirements.
- P. Sound Reduction (Factory-mounted):
 - 1. Ultra Quiet - Low speed, reduced noise fans
 - 2. Compressor Acoustic Sound Blankets
- Q. Vibration Isolation (Field-mounted):
 - 1. Neoprene Pad Isolators.
 - 2. 1" Deflection Spring Isolators: Level adjustable, spring and cage type isolators for mounting under the unit base rails.
 - 3. 2" Deflection Seismic Isolators: Level adjustable, restrained mounts in rugged welded steel housing with vertical and horizontal limit stops. Housings shall be designed to withstand a minimum 1.0g accelerated force in all directions to 2 inches.

Guide Specifications - continued

PART 3 – EXECUTION

3.01 INSTALLATION

- A. General: Rig and Install in full accordance with Manufacturers requirements, Project drawings, and Contract documents.
- B. Location: Locate chiller as indicated on drawings, including cleaning and service maintenance clearance per Manufacturer instructions. Adjust and level chiller on support structure.
- C. Components: Installing Contractor shall provide and install all auxiliary devices and accessories for fully operational chiller.
- D. Electrical: Co-ordinate electrical requirements and connections for all power feeds with Electrical Contractor (Division 16).
- E. Controls: Co-ordinate all control requirements and connections with Controls Contractor.
- F. Finish: Installing Contractor shall paint damaged and abraded factory finish with touch-up paint matching factory finish.