

CATALOG

# FW and FL Fan-Coil Units Floor-Mounted, Vertical



# TABLE OF CONTENTS

Features and Benefits .....	3
Construction Features .....	4
Standard and Optional Features .....	9
Coil Data .....	10
Physical Data .....	12
Electric Heat .....	14
Fan Performance .....	15
Motor and Fan Data .....	24
Sound Data .....	25
Dimensional Data .....	26
Piping Packages .....	34
Guide Specifications .....	42



**NOTES:**

- Johnson Controls offers Web-Select®, the industry’s first web-based rating and selection program for complete unit, coil and sound selection. See your representative for more information.
- Some drawings are not shown in this catalog.
- All data herein is subject to change without notice.
- Drawings not for installation purposes.
- ETL Report Number J99014414-001 and 3096645CRT-002.
- City of New York Material and Equipment Acceptance (MEA) File Number 106-02-E.

## FEATURES AND BENEFITS

---

### DESIGN FLEXIBILITY

The Johnson Controls vertical floor mounted fan coil units are designed to maximize flexibility of selection and installation.

The units are also designed to exceed the stringent quality standards of the institutional market, while remaining cost competitive in the light commercial segment of the market.

Johnson Controls vertical fan coil units set the new standards for quality, flexibility, and competitive pricing.

### DESIGN FLEXIBILITY

The extensive variety of standard options available on vertical floor fan coil units are where you find the versatility to fit any HVAC system designer's needs. Models FWX and FWI allow for additional height and width dimensions to meet architectural demand.

Options include: single wall stainless steel drain pan; MERV 7, MERV 8 and MERV 13 filters; and electric heat with single point power connection. All electric heat units are listed with ETL as an assembly and carry the cETL label.

All units comply with the latest edition of ARI Standard 440 for testing and rating fan coil units, are certified, and display the ARI symbol.

High efficiency motors, fan relays, disconnects and fusing mean easier coordination between mechanical and electrical trades.

Coil options allow for three or four row chilled water or DX cooling coils, and one or two row hot water or steam heating coils.

Silent solid state relays are available for fan and electric heat control in sound sensitive environments.

### CONVENIENT INSTALLATION

All vertical floor fan coils are shipped completely assembled, reducing field installation time and labor. All units are thoroughly inspected and tested prior to shipment, eliminating potential problems at startup. Motor wiring is brought to a junction box on the inside of the unit end pocket, reducing electrical hook-up time.

Factory furnished valve packages assure proper fit, operation and performance.

For fast track jobs, the vertical floor fan coil is available on Quick Ship with 5, 10 or 15 day lead times.

### OPTIMUM BUILDING PERFORMANCE

Concealed vertical floor fan coil chassis are built from galvanized steel. This metal surpasses the ASTM 125 hour salt spray test for corrosion and rust. Exposed cabinet models are powder coated galvanized steel.

All units, with or without electric heat, are cETL listed and labeled. All wiring is in compliance with NEC, assuring safety and quality for the owner.

Floor mounted cabinet models feature finned tubular heating elements in the reheat position, protecting room occupants from electrical shock.

Vertical floor fan coil units have a removable fan/drain pan assembly. The entire fan assembly can be easily removed from the unit and serviced on a workbench.

Filters are easily replaceable from the return air toe space without the need for tools or removal of the front panel (FW only).

# CONSTRUCTION FEATURES

## MODEL FWX & FLX

(Photo as shown for FWX). FW and FL Series fan coils have many standard and optional features which are unique to the industry. See page 6 for a complete listing.

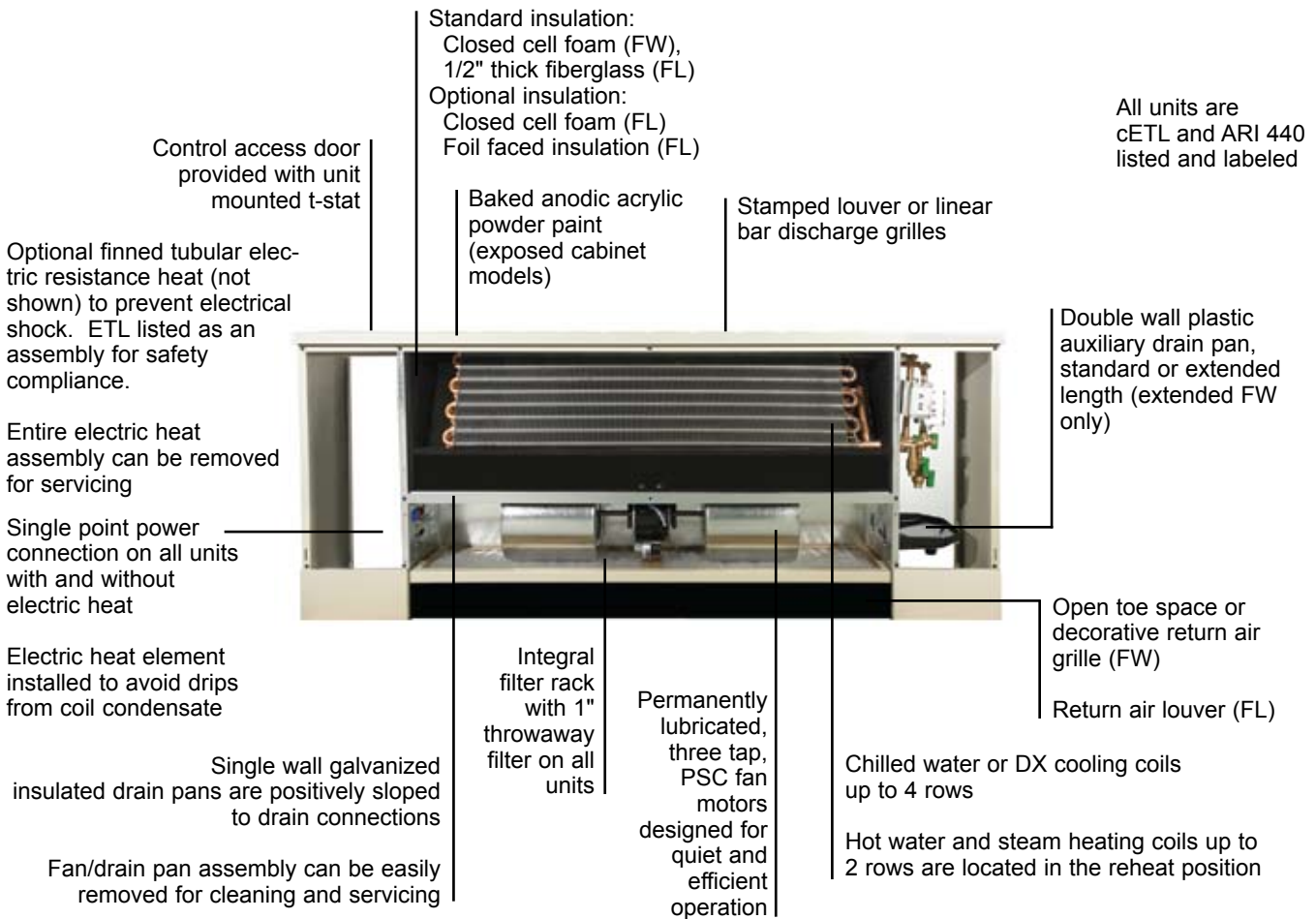

**MODEL FWI**  
 Vertical Sloped Top



**MODEL FWC**  
 Vertical Concealed



**MODEL FLC**  
 Low-Profile Concealed



## CONSTRUCTION FEATURES

### MODELS FWX/FWI/FWC



#### END POCKETS

The 8" end pockets allow for accessibility and service of optional factory piping packages and controls. End panels are removable to allow for even greater access.



#### FAN DECK

The fan/drain pan assembly is easily removable for service access to motors and blowers at, or away from, the unit.

#### DRAIN PAN

The sloped insulated primary drain pan is available in stainless steel construction. Standard drain pan is externally insulated, single wall galvanized steel. The FW Series fan/drain pan assembly is easily removable for cleaning.



#### COILS

All fan coils are available in 2 or 4 pipe configurations. The heating coil is standard in the reheat position. Heating and cooling coils are available with the same or opposite end connections. Access for cleaning on the entering air side is available when the drain pan is removed. Coils are removable for service.



#### FILTER

The filter is easily replaceable through the return air toe space without requiring removal of the front panel.

#### POWDER COATED PAINTED SURFACE

Exposed cabinet Models FWX and FWI, as well as supply and return air grilles and the FWC wall recessing panel, feature a powder coat finish that resists scuffing, scratching, fading, and finger-prints.



## CONSTRUCTION FEATURES

### MODELS FWX/FWI/FWC



#### CONTROL ENCLOSURE

The FW control enclosure provides adequate space for the unit controller and fan coil relay. The fan coil relay is designed to limit diagnostic problems, while allowing for multi-voltage fan power input. The board is designed for factory installed, color coded, plug and play connections designed to ensure accurate wiring.



#### PIPING PACKAGES

Factory installed piping packages come equipped with components specific to the project. Actuators ship with color coded plug and play connections for quick, accurate installations.

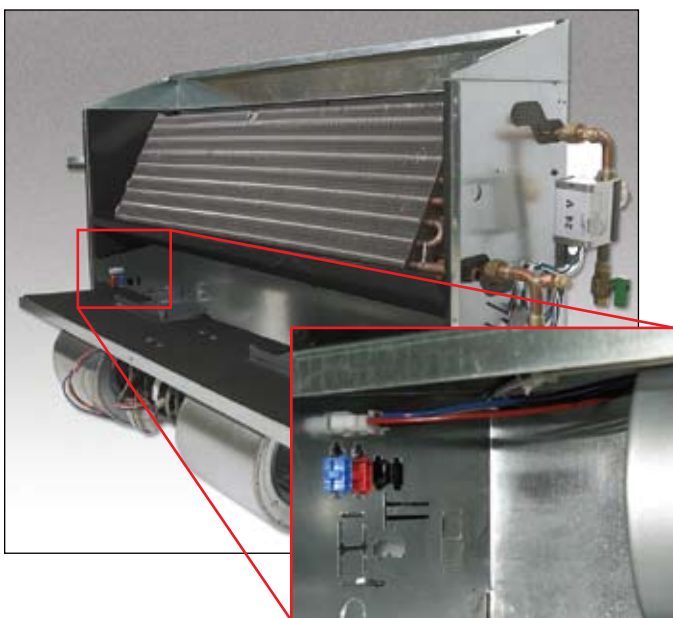

#### FAN DECK REMOVAL

FW units allow for a single technician to service the fan/motor by keeping the fan deck to less than 44". Motors are supplied with quick connectors to allow electrical service without the need for tools.



#### LID REMOVAL

Top panel is removable from fan coil without the need to disconnect piping or electrical wires.

## CONSTRUCTION FEATURES

### MODELS FLX/FLC

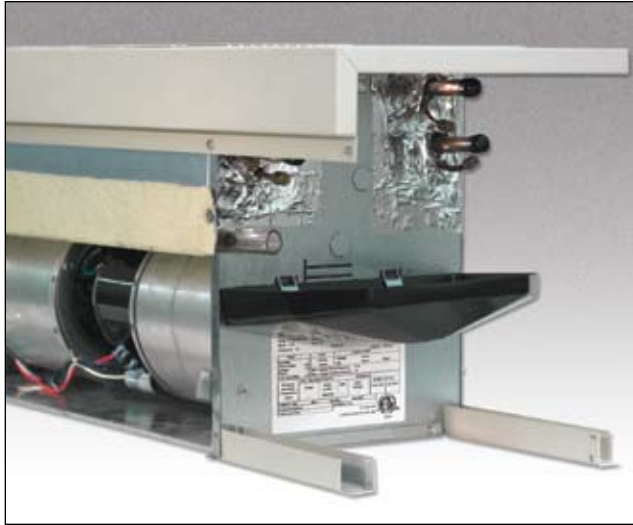

#### END POCKETS

The 8" end pockets allow for accessibility and service of optional factory piping packages and controls. End panels are removable to allow for even greater access.



#### FAN DECK

The fan/drain pan assembly is easily removable for service access to motors and blowers at, or away from, the unit.

#### DRAIN PAN

The sloped insulated primary drain pan is available in stainless steel construction. The standard drain pan is externally insulated, single wall galvanized steel. A non-metallic auxiliary drip pan is provided as standard. The FL Series fan/drain pan assembly is easily removable for cleaning.



#### COILS

All units are available in 2 or 4 pipe configurations. The heating coil is standard in the reheat position. Heating and cooling coils are available with same end connections. Access for cleaning on the entering air side is available when the drain pan is removed. Coils are removable for service.

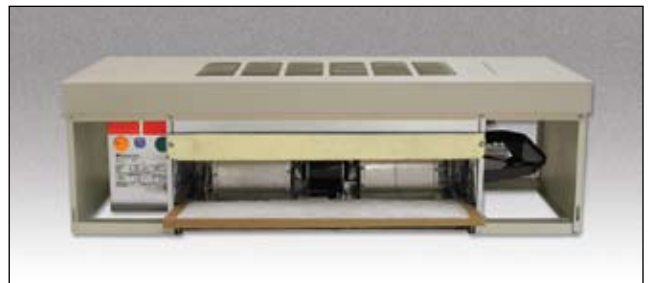

#### FILTER

The filter is easily replaceable through the return air toe space without requiring removal of the front panel.

#### POWDER COATED PAINTED SURFACE

Exposed cabinet Model FLX, as well as supply and return air grilles and the FLC wall recessing panel, feature a powder coat finish that resists scuffing, scratching, fading, and fingerprints.

## CONSTRUCTION FEATURES

### MODELS FLX/FLC



#### ELECTRICAL ENCLOSURE

The front access electrical enclosure provides access to all electric heat and control components. Terminal strips are furnished for simple power and control wiring connections. Multiple knockouts allow wiring entries from either the top or bottom of the compartment.



#### CONCEALED MODEL FLC

For built-in applications, Model FLC features a 1" top supply with duct collar.

#### ELECTRIC HEAT

A variety of kW and voltage configurations are available. Options include door interlock disconnects, low voltage controls, and silent solid state relays. All control and electric heat configurations include single point power connection and are cETL listed as an assembly.





## STANDARD AND OPTIONAL FEATURES

### STANDARD FEATURES

#### Construction

##### *All Units*

- ARI 440 certified and labeled
- Galvanized steel construction
- Insulation, FW: elastomeric closed cell foam
- Insulation, FL: 1/2" thick fiberglass insulation
- Integral filter rack with 1" throwaway filter

##### *Concealed Units*

- Top supply with duct collar

##### *Exposed Units*

- Top stamped louver supply grille
- Durable powder coat paint
- End pockets with removable panels
- 18 gauge exterior panel construction
- Flat top
- Sloped top (FW only)

#### Coils

- Cooling - 3 or 4 row chilled water or DX, heat pump compatible
- Heating - 1 or 2 row hot water or steam – reheat position
- 1/2" O.D. seamless copper tubes
- 0.016" tube wall thickness
- High efficiency aluminum fin surface for optimizing heat transfer, pressure drop and carryover
- Left or right hand, same or [opposite - FW only] end connections
- Removable for service
- Manual air vents

#### Drain Pans

- Single wall, galvanized steel, externally insulated – fire retardant and antimicrobial
- Positively sloped to drain connection
- 3/4" M.P.T. auxiliary drain pan connection
- Double wall plastic auxiliary drip pan

#### Fan Assemblies

- Forward curved, DWDI centrifugal type
- 115 volt, single phase, three speed PSC motors
- Quick disconnect motor connections
- Removable for service

#### Electrical

- cETL listed for safety compliance
- Electrical junction box for field wiring terminations
- Terminal block for field connections

#### Electric Heat

- Finned tubular element on all floor mounted units protects against electrical shock
- ETL listed as an assembly for safety compliance
- Integral electric heat assembly with removable elements for easy service
- Automatic reset primary and back-up secondary thermal limits
- Single point power connection

### OPTIONAL FEATURES

#### Construction

##### *All Units*

- Foil faced fiberglass insulation (FL)
- Elastomeric closed cell foam insulation (FL)
- Manual and motorized outside air dampers
- Spare 1" throwaway filters
- 1" pleated filters (MERV 7)
- Wall boxes (FW only)
- Leveling legs

##### *Concealed Units*

- Wall recessing panels (FW only)

##### *Exposed Units*

- Linear bar discharge grille, powder coated
- 16 gauge front panel (FW only)
- Return air louver grille
- 2" - 8" falsebacks (FW only)
- Extended end pockets (FW only)
- Tamper proof fasteners

#### Coils

- Automatic air vents
- Stainless steel coil casings
- 0.025" tube wall (standard on steam)

#### Drain Pans

- Stainless steel construction with external insulation
- Double wall plastic auxiliary drain pan -- extended length (FW only)
- Stainless steel auxiliary drain pan -- extended length (FW only)

#### Fan Assemblies

- 208-230 & 277 volt, 60 Hz and 220 volt, 50 Hz motors

#### Electrical

- SCR fan speed controller
- Fan relay packages
- Silent solid state fan relays (FW only)
- Toggle disconnect switch
- Condensate overflow switch (auxiliary drain pan)
- Main fusing
- Unit and remote mounted three speed fan switches

#### Electric Heat

- Door interlocking disconnect switches
- Main fusing
- Silent relay/contactors (FW only)

#### Piping Packages

- Factory assembled – shipped loose for field installation
- 1/2" and 3/4", 2-way and 3-way normally closed, two position electric motorized valves
- Isolation ball valves with memory stop
- 4 pipe with 3-way valve (FW only)
- Fixed and adjustable flow control devices
- Unions and P/T ports
- Modulating control valves
- High pressure close-off actuators (1/2" = 50 PSIG; 3/4" = 25 PSIG)

#### Thermostats

- Analog, digital display, or programmable
- Unit and remote mounted, with integral three speed fan switch
- 2 and 4-pipe control sequences
- Automatic and manual changeover

# COIL DATA: FW SERIES

## COILS

Johnson Controls offers hot water, chilled water, direct expansion (DX - FW only), and standard single tube steam coils for specific application with all Vertical Floor fan coil units. Strict on-site inspection before, during, and after installation guarantees the highest quality and performance available.

### STANDARD FEATURES

- Cooling - 3 or 4 row chilled water or [DX - FW only]
- Heating - 1 or 2 row hot water or steam
- Total rows of cooling and heating coils:  
FW: 4 maximum, FL: 5 maximum
- 1/2" O.D. seamless copper tubes
- 0.016" tube wall thickness
- High efficiency aluminum fin surface for optimizing heat transfer, pressure drop and carryover
- Left or right hand, same or [opposite side - FW only] connections
- Manual air vents

### OPTIONAL FEATURES

- Automatic air vents
- Stainless steel coil casings
- 0.025" tube wall thickness (standard on steam coils)
- DX coils (FW only) are heat pump compatible

Johnson Controls offers Web-Select® fan coil rating and selection program for complete unit, coil and sound selection. See your representative for more information.

## FW NOMINAL COIL CONNECTION SIZES

UNIT SIZE	COIL TYPE											
	HOT WATER		CHILLED WATER		STEAM		REFRIGERANT (DX)					
	1 ROW	2 ROW	3 ROW	4 ROW	1 ROW	2 ROW	2 ROW		3 ROW		4 ROW	
							Liquid	Suction	Liquid	Suction	Liquid	Suction
02 - 12	5/8 [16]	5/8 [16]	5/8 [22]	5/8 [22]	5/8 [16]	5/8 [16]	3/8 [10]	5/8 [16]	3/8 [10]	5/8 [16]	3/8 [10]	5/8 [16]

### NOTES:

1. Connection sizes are for standard circuit coils. Consult factory for special applications.
2. See submittal drawings for connection locations.
3. All dimensional data is outside diameter (O.D.), measured in inches [millimeters].

## FW FACE AREA, FREE AREA AND FILTER SIZES

UNIT SIZE	COIL FACE AREA	DISCHARGE GRILLE FREE AREA	FILTER FACE AREA	NOMINAL FILTER SIZES
02	0.97 [.090]	0.47 [.044]	1.40 [.130]	9.25 X 21.75 X 1 [235 X 552 X 25.4]
03	1.25 [.116]	0.56 [.052]	1.65 [.154]	9.25 X 25.75 X 1 [235 X 654 X 25.4]
04	1.67 [.155]	0.66 [.061]	2.04 [.189]	9.25 X 31.75 X 1 [235 X 806 X 25.4]
06	2.36 [.219]	0.94 [.087]	2.68 [.249]	9.25 X 41.75 X 1 [235 X 1060 X 25.4]
08	2.50 [.023]	0.94 [.087]	2.79 [.260]	(2) 9.25 X 21.75 X 1 [235 X 552 X 25.4]
10	3.47 [.322]	1.31 [.122]	3.69 [.343]	(1) 9.25 X 25.75 X 1 [235 X 654 X 25.4]
				(1) 9.25 X 31.75 X 1 [235 X 806 X 25.4]
12	4.03 [.374]	1.50 [.139]	4.19 [.389]	(3) 9.25 X 21.75 X 1 [235 X 552 X 25.4]

### NOTES:

1. Face and free areas are in square feet [square meters].
2. Filter sizes are in inches [millimeters].

## FW HEATING CAPACITY

UNIT TYPE	UNIT SIZE	NOM. CFM	1 ROW			2 ROW		
			QS (MBH)	GPM	WPD	QS (MBH)	GPM	WPD
FW	02	230	7856	0.4	0.2	14273	0.7	1.0
FW	03	300	10980	0.6	0.4	19151	1.0	1.9
FW	04	430	15945	0.8	0.8	27475	1.4	4.2
FW	06	540	21791	1.1	1.7	36747	1.9	8.8
FW	08	600	23847	1.2	2.1	40072	2.1	10.7
FW	10	830	34277	1.8	5.1	54722	2.8	3.4
FW	12	920	38814	2.0	7.0	62206	3.2	4.7

NOTE: Based on 70°F DB EAT, 180°F EWT, 40°F temperature drop, high fan speed.

## COIL DATA: FL SERIES

### FL NOMINAL COIL CONNECTION SIZES

UNIT SIZE	COIL CONNECTION SIZE					
	HOT WATER			CHILLED WATER		
	1 ROW	2 ROW	3 ROW	2 ROW	3 ROW	4 ROW
02 & 03	5/8 [16]	5/8 [16]	5/8 [16]	5/8 [16]	5/8 [16]	5/8 [16]
04 & 06	5/8 [16]	5/8 [16]	5/8 [16]	5/8 [16]	5/8 [16]	7/8 [19]

#### NOTES:

1. Connection sizes are for standard circuit coils. Consult factory for special applications.
2. See submittal drawings for connection locations.
3. All dimensional data is outside diameter (O.D.), measured in inches [millimeters].

### FL FACE AREA AND FILTER SIZES

UNIT SIZE	COIL FACE AREA	DISCHARGE GRILLE DIMENSIONS	FILTER FACE AREA	NOMINAL FILTER SIZES
02	1.18 [0.11]	17 x 5.25 [432 x 133]	1.12 [0.10]	21.5 x 7.5 [546 x 191]
03	1.53 [0.14]	22 x 5.25 [559 x 133]	1.38 [0.13]	26.5 x 7.5 [673 x 191]
04	2.08 [0.19]	30 x 5.25 [762 x 133]	1.80 [0.17]	34.5 x 7.5 [876 x 191]
06	3.06 [0.28]	44 x 5.25 [1118 x 133]	2.53 [0.23]	48.5 x 7.5 [1232 x 191]

#### NOTES:

1. Face and free areas are in square feet [square meters].
2. Filter sizes are in inches [millimeters].

### FL HEATING CAPACITY

UNIT TYPE	UNIT SIZE	NOM. CFM	1 ROW			2 ROW			3 ROW		
			QS (MBH)	GPM	WPD	QS (MBH)	GPM	WPD	QS (MBH)	GPM	WPD
FLC FLX	02	200	9.2	0.6	0.6	15.4	1.1	2.6	19.0	1.3	5.7
	03	300	13.4	0.9	1.2	22.4	1.5	5.6	27.2	1.9	2.0
	04	400	18.5	1.3	2.4	30.4	2.1	11.1	37.0	2.5	3.9
	06	600	28.2	1.9	6.0	44.8	3.1	4.7	56.0	3.8	9.8

Note: Based on 70°F DB EAT, 180°F EWT, 30°F temperature drop, high fan speed.

## PHYSICAL DATA: FW SERIES

### FW ARI STANDARD RATINGS

MODEL / SIZE	COIL		AIRFLOW CFM (dry flow)	COOLING CAPACITY		WATER		POWER INPUT (WATTS)
	Rows	FPI		QT (BTUH)	QS (BTUH)	Flow Rate (GPM)	WPD ft-wg	
FW 02	3	10	230	7200	4800	1.5	6.5	45
FW 03	3	10	320	8900	6400	1.8	9	60
FW 04	3	10	450	15400	11000	3	3.91	70
FW 06	3	10	570	21700	15000	4.4	8.11	80
FW 08	3	10	630	23800	16500	4.8	10.07	114
FW 10	3	10	835	31700	21900	6.3	7.01	132
FW 12	3	10	980	37500	25800	7.4	10.56	142

**NOTE:** Based on 80°F DB and 67°F WB EAT, 45°F EWT, 10°F temperature rise, high fan speed. Motor type is PSC and motor voltage is 115/1/60. Airflow under dry coil conditions. Models FWX and FWI tested at 0.0" external static pressure. Model FWC tested at 0.05" external static pressure.

### FW UNIT WEIGHT DATA

COMPONENT		UNIT SIZE						
		02	03	04	06	08	10	12
FWC BASE UNIT		36 [16]	45 [20]	55 [25]	62 [28]	66 [30]	92 [42]	105 [48]
FWX BASE UNIT		66 [30]	74 [34]	87 [39]	96 [44]	102 [46]	131 [59]	149 [68]
FWI BASE UNIT		68 [31]	76 [34]	89 [40]	99 [45]	102 [46]	135 [61]	153 [69]
TOTAL COIL ROWS	1 ROW - DRY	11 [5]	12 [5]	14 [6]	18 [8]	19 [9]	23 [10]	26 [12]
	1 ROW - WET	14 [6]	15 [7]	20 [9]	24 [11]	25 [11]	32 [15]	37 [17]
	2 ROW - DRY	14 [6]	15 [7]	19 [9]	22 [10]	24 [11]	30 [14]	33 [15]
	2 ROW - WET	19 [9]	20 [9]	25 [11]	31 [14]	32 [15]	41 [19]	47 [21]
	3 ROW - DRY	18 [8]	20 [9]	23 [10]	29 [13]	30 [14]	37 [17]	43 [20]
	3 ROW - WET	23 [10]	25 [11]	32 [15]	39 [18]	41 [19]	52 [24]	61 [28]
	4 ROW - DRY	22 [10]	25 [11]	30 [14]	36 [16]	39 [18]	47 [21]	54 [24]
	4 ROW - WET	30 [14]	32 [15]	41 [19]	50 [23]	52 [24]	65 [29]	77 [35]

**NOTE:** Unit weight data is in pounds [kilograms].

## PHYSICAL DATA: FL SERIES

### FL ARI STANDARD RATINGS

MODEL / SIZE	COIL		AIRFLOW CFM (DRY FLOW)	COOLING CAPACITY		WATER		POWER INPUT (WATTS)
	ROWS	FPI		QT (MBH)	QS (MBH)	Flow Rate (GPM)	WPD FT. WG.	
FLC/FLX 02	3	10	200	6500	4300	1.6	11.7	75
FLC/FLX 03	3		300	9500	6500	2.0	3.4	75
FLC/FLX 04	3		400	14000	9500	2.9	7.4	75
FLC/FLX 06	3		600	20000	15000	5.2	9.9	140

**NOTE:** Based on 80°F DB and 67°F WB EAT, 45°F EWT, 10°F temperature rise, high fan speed. Motor type is PSC and motor voltage is 115/1/60. Airflow under dry coil conditions. Model FLX tested at 0.0" external static pressure. Model FLC tested at 0.05" external static pressure.

### FL UNIT WEIGHT DATA

COMPONENT		UNIT SIZE			
		02	03	04	06
FLC BASE UNIT, STD HEIGHT		51 [23]	58 [26]	65 [29]	77 [35]
FLC BASE UNIT, EXT HEIGHT		65 [29]	69 [31]	74 [34]	84 [38]
FLX BASE UNIT, STD HEIGHT		90 [41]	97 [44]	104 [47]	116 [53]
FLX BASE UNIT, EXT HEIGHT		104 [47]	108 [49]	113 [51]	123 [56]
TOTAL COIL ROWS	1 ROW - DRY	11 [5]	13 [6]	15 [7]	17 [8]
	1 ROW - WET	14 [6]	17 [8]	20 [9]	23 [10]
	2 ROW - DRY	14 [6]	17 [8]	20 [9]	22 [10]
	2 ROW - WET	20 [9]	25 [11]	30 [13]	34 [15]
	3 ROW - DRY	19 [8]	22 [10]	25 [11]	29 [13]
	3 ROW - WET	28 [13]	34 [15]	40 [18]	47 [21]
	4 ROW - DRY	24 [11]	29 [13]	33 [15]	37 [17]
	4 ROW - WET	36 [16]	45 [20]	53 [24]	61 [28]
	5 ROW - DRY	31 [14]	37 [17]	43 [19]	49 [22]
	5 ROW - WET	46 [21]	57 [26]	68 [31]	79 [36]

**NOTE:** Unit weight data is in pounds [kilograms].

# ELECTRIC HEAT

Johnson Controls offers electric heating coils for specific application with all Vertical Floor Series Fan Coil units. This allows the flexibility to provide an unrivaled amount of electric heat options in one complete package.

### STANDARD FEATURES

- ETL listed as an assembly for safety compliance
- Single point power connection
- Mounted in reheat position
- Automatic reset primary and back-up secondary thermal limits
- Internal wiring rated at 105°C
- Integral electric heat assembly with removable element for easy service
- Stainless steel terminals and hardware
- Finned tubular heater virtually eliminates the risk of shock from accidental contact.



### OPTIONAL FEATURES

- Silent solid state relays (FW only) on heaters up to 18 amps
- Door interlocking disconnect switch
- Main fusing

### USEFUL FORMULAS

$$kW^* = \frac{CFM \times \Delta T \times 1.085^{**}}{3413}$$

$$1\emptyset \text{ AMPS} = \frac{kW \times 1000}{\text{Volts}}$$

\* 1kW = 3413 BTU/H

\*\* Capacity at sea level

### Altitude Considerations:

Reduce by 0.034 for each 1000 ft. of altitude above sea level.

Example: 5000 ft./1000 ft. = 5

5 x 0.034 = 0.17

1.085 - 0.17 = 0.915

### ELECTRICAL CALCULATIONS INFORMATION

1. Contact your local Johnson Controls sales office.
2. Non-Fused Door Interlock Disconnect Switch shall be sized according to MCA.
3. Fused Door Interlock Disconnect Switch and Main Fusing shall be sized according to MOP.

## FW ELECTRIC HEAT SELECTION CHART (AMPS)

UNIT SIZE	MBH	3.4	5.1	6.8	10.2	13.7	17.1	20.5
	KW	1.0	1.5	2.0	3.0	4.0	5.0	6.0
	VOLTS	AMPS						
02	115	8.3						
	208	4.8						
	240	4.2						
	277	3.6						
03	115	8.3	12.5					
	208	4.8	7.2					
	240	4.2	6.3					
	277	3.6	5.4					
04	115	8.3	12.5	16.7				
	208	4.8	7.2	9.6				
	240	4.2	6.3	8.3				
	277	3.6	5.4	7.2				
06	115	8.3	12.5	16.7	25.0			
	208	4.8	7.2	9.6	14.4			
	240	4.2	6.3	8.3	12.5			
	277	3.6	5.4	7.2	10.8			
08	115	8.3	12.5	16.7	25.0			
	208	4.8	7.2	9.6	14.4	19.2		
	240	4.2	6.3	8.3	12.5	16.7		
	277	3.6	5.4	7.2	10.8	14.4		
10	115	8.3	12.5	16.7	25.0			
	208	4.8	7.2	9.6	14.4	19.2	24.0	
	240	4.2	6.3	8.3	12.5	16.7	20.8	
	277	3.6	5.4	7.2	10.8	14.4	18.1	
12	115	8.3	12.5	16.7	25.0			
	208	4.8	7.2	9.6	14.4	19.2	24.0	28.9
	240	4.2	6.3	8.3	12.5	16.7	20.8	25.0
	277	3.6	5.4	7.2	10.8	14.4	18.1	21.7

### NOTES:

1. Shaded areas of the electric heat selection chart indicate kW and voltage options not available.
2. Available voltages are single phase, 60 hertz.
3. Size heater for Leaving Air Temperature (LAT) less than 104°F.
4. Silent, solid state heater relay is available for heater currents less than 18 amps.
5. Ask your representative about continuously modulating electric heat using SSR and special control options.

## FL ELECTRIC HEAT SELECTION CHART (AMPS)

UNIT SIZE	MBH	3.4	5.1	6.8	10.2
	KW	1.0	1.5	2.0	3.0
	VOLTS	AMPS			
02	115	8.7			
	208	4.8			
	230	4.4			
	277	3.6			
03	115	8.7	13.1		
	208	4.8	7.2		
	230	4.4	6.5		
	277	3.6	5.4		
04	115	8.7	13.1	17.4	26.1
	208	4.8	7.2	9.6	14.4
	230	4.4	6.5	8.7	13.1
	277	3.6	5.4	7.2	10.8
06	115	8.7	13.1	17.4	26.1
	208	4.8	7.2	9.6	14.4
	230	4.4	6.5	8.7	13.1
	277	3.6	5.4	7.2	10.8

### NOTES:

1. See notes 1 through 3 above.

**FAN PERFORMANCE: FW SERIES**

UNIT DATA					3 ROW CHILLED WATER COIL					
UNIT SIZE	AIRFLOW (CFM)	MOTOR (HP)	FAN AMPS (FLA)	FAN WATTS	LAT DB/WB (°F)	TOTAL CAPACITY (MBH)	SENSIBLE CAPACITY (MBH)	EWT/LWT (°F)	FLUID FLOW (GPM)	FLUID PD (FT.)
2	233	(1) 1/50	0.4	45	55.6 / 54	6.2	5.0	45 / 55	1.2	4.6
3	307	(1) 1/20	0.5	60	55 / 53.3	8.7	6.8	45 / 55	1.7	7.8
4	448	(1) 1/20	0.6	70	57 / 55	10.6	8.9	45 / 55	2.1	2.2
6	562	(1) 1/20	0.7	80	55.1 / 53.5	15.7	12.4	45 / 55	3.1	5.0
8	657	(1) 1/10	1.0	114	55.4 / 53.6	18.1	14.2	45 / 54.9	3.6	6.4
10	854	(2) 1/20	1.1	132	54.7 / 53	25.0	19.2	45 / 55.1	4.9	13.8
12	902	(2) 1/20	1.2	142	54.5 / 53	26.3	20.4	45 / 55	5.2	5.9
2	233	(1) 1/50	0.4	45	54.9 / 53.3	6.6	5.2	42 / 54.1	1.1	3.9
3	307	(1) 1/20	0.5	60	53.8 / 52.2	9.6	7.2	42 / 54	1.6	7.3
4	448	(1) 1/20	0.6	70	53.7 / 52	14.2	10.5	42 / 54	2.4	14.4
6	562	(1) 1/20	0.7	80	54.1 / 52.5	17.1	13.0	42 / 54	2.8	4.4
8	657	(1) 1/10	1.0	114	54.4 / 52.6	19.8	15.0	42 / 54	3.3	5.7
10	854	(2) 1/20	1.1	132	53.3 / 51.6	27.9	20.5	42 / 54	4.6	12.5
12	902	(2) 1/20	1.2	142	53.3 / 51.9	29.0	21.6	42 / 54	4.8	5.2
2	233	(1) 1/50	0.4	45	56.7 / 54.9	5.6	4.7	42 / 56	0.8	2.4
3	307	(1) 1/20	0.5	60	55.3 / 53.6	8.5	6.7	42 / 56.1	1.2	4.9
4	448	(1) 1/20	0.6	70	54.7 / 52.9	13.2	10.0	42 / 55.9	1.9	10.1
6	562	(1) 1/20	0.7	80	55.4 / 53.8	15.2	12.1	42 / 55.9	2.2	2.8
8	657	(1) 1/10	1.0	114	55.6 / 53.8	17.8	14.0	42 / 55.9	2.5	3.8
10	854	(2) 1/20	1.1	132	54.4 / 52.6	25.7	19.5	42 / 56.1	3.6	8.4
12	902	(2) 1/20	1.2	142	53.5 / 52	28.7	21.4	42 / 56.1	4.1	11.1
2	233	(1) 1/50	0.4	45	59.2 / 56.8	4.4	4.1	42 / 58	0.5	1.2
3	307	(1) 1/20	0.5	60	56.7 / 54.8	7.4	6.2	42 / 58	0.9	3.3
4	448	(1) 1/20	0.6	70	55.9 / 53.9	12.0	9.5	42 / 58	1.5	7.6
6	562	(1) 1/20	0.7	80	57.1 / 55.2	13.1	11.1	42 / 58	1.6	1.7
8	657	(1) 1/10	1.0	114	57.2 / 55.1	15.4	12.9	42 / 58	1.9	2.4
10	854	(2) 1/20	1.1	132	55.5 / 53.7	23.4	18.4	42 / 58	2.9	5.9
12	902	(2) 1/20	1.2	142	54.6 / 53	26.4	20.3	42 / 58.1	3.3	8.0

**NOTE:** Based on 75°F DB EAT, 63°F WB, and 3 row cooling coil. All selections made at High speed, .05" ESP, 115 V motor, Concealed style of unit, Altitude of 0'.

## FAN PERFORMANCE DATA: FW SERIES

UNIT DATA					4 ROW CHILLED WATER COIL					
UNIT SIZE	AIRFLOW (CFM)	MOTOR (HP)	FAN AMPS (FLA)	FAN WATTS	LAT DB/WB (°F)	TOTAL CAPACITY (MBH)	SENSIBLE CAPACITY (MBH)	EWT/LWT (°F)	FLUID FLOW (GPM)	FLUID PD (FT.)
2	228	(1) 1/50	0.4	45	52.5 / 51.6	7.5	5.7	45 / 55	1.5	7.8
3	297	(1) 1/20	0.5	60	52 / 51.1	10.1	7.6	45 / 54.9	2.0	12.0
4	426	(1) 1/20	0.6	70	53.6 / 52.6	12.9	10.1	45 / 55.1	2.5	4.0
6	543	(1) 1/20	0.7	80	52.2 / 51.3	18.3	13.7	45 / 55	3.6	8.2
8	620	(1) 1/10	1	114	52.5 / 51.5	20.6	15.5	45 / 55.1	4.1	9.9
10	821	(2) 1/20	1.1	132	52.9 / 51.8	26.4	20.1	45 / 55.1	5.2	6.6
12	848	(2) 1/20	1.2	142	52 / 51.1	28.8	21.6	45 / 55	5.8	8.4
2	228	(1) 1/50	0.4	45	51.1 / 50.3	8.3	6.0	42 / 53.9	1.4	7.3
3	297	(1) 1/20	0.5	60	50.3 / 49.5	11.3	8.1	42 / 53.9	1.9	11.4
4	426	(1) 1/20	0.6	70	52.5 / 51.5	14.1	10.6	42 / 54	2.3	3.6
6	562	(1) 1/20	0.7	80	54.1 / 52.5	17.1	13.0	42 / 54	2.8	4.4
8	620	(1) 1/10	1	114	50.9 / 50	22.9	16.5	42 / 54.1	3.8	9.2
10	821	(2) 1/20	1.1	132	51.4 / 50.4	29.4	21.4	42 / 53.9	4.9	6.0
12	848	(2) 1/20	1.2	142	50.4 / 49.6	32.2	23.1	42 / 54	5.3	7.8
2	228	(1) 1/50	0.4	45	52.7 / 51.8	7.4	5.6	42 / 55.9	1.1	5.0
3	297	(1) 1/20	0.5	60	51.6 / 50.7	10.4	7.7	42 / 55.9	1.5	8.9
4	426	(1) 1/20	0.6	70	54.2 / 53.2	12.3	9.8	42 / 56	1.7	2.2
6	543	(1) 1/20	0.7	80	52 / 51.1	18.5	13.8	42 / 56.1	2.6	5.1
8	620	(1) 1/10	1	114	52.1 / 51.2	21.1	15.7	42 / 56.1	3.0	6.5
10	821	(2) 1/20	1.1	132	51.2 / 50.2	29.8	21.6	42 / 56.1	4.2	13.8
12	848	(2) 1/20	1.2	142	51.7 / 50.8	29.5	21.8	42 / 56	4.2	5.1
2	228	(1) 1/50	0.4	45	54.4 / 53.4	6.4	5.2	42 / 58	0.8	3.2
3	297	(1) 1/20	0.5	60	53.1 / 52.1	9.4	7.2	42 / 58	1.2	6.3
4	426	(1) 1/20	0.6	70	52.4 / 51.4	14.2	10.6	42 / 58	1.8	12.6
6	543	(1) 1/20	0.7	80	53.4 / 52.4	16.6	13.0	42 / 58	2.1	3.5
8	620	(1) 1/10	1	114	53.4 / 52.3	19.2	14.8	42 / 57.9	2.4	4.6
10	821	(2) 1/20	1.1	132	52.1 / 51.2	27.9	20.7	42 / 57.9	3.5	10.5
12	848	(2) 1/20	1.2	142	51.3 / 50.5	30.3	22.2	42 / 58	3.8	13.0

**NOTE:** Based on 75°F DB EAT, 63°F WB, and 4 row cooling coil. All selections made at High speed, .05" ESP, 115 V motor, Concealed style of unit, Altitude of 0'.

UNIT DATA					3 ROW CHILLED WATER COIL					1 ROW HOT WATER COIL			
UNIT SIZE	AIRFLOW (CFM)	MOTOR (HP)	FAN AMPS (FLA)	FAN WATTS	LAT DB/WB (°F)	TOTAL CAPACITY (MBH)	SENSIBLE CAPACITY (MBH)	FLUID FLOW (GPM)	FLUID PD (FT.)	LAT DB (°F)	SENSIBLE CAPACITY (MBH)	FLUID FLOW (GPM)	FLUID PD (FT.)
2	228	(1) 1/50	0.4	45	55.6 / 54	6.0	4.9	1.2	4.4	95.3	6.3	0.3	0.12
3	297	(1) 1/20	0.5	60	54.8 / 53.2	8.5	6.6	1.7	7.7	97.8	9.0	0.5	0.21
4	426	(1) 1/20	0.6	70	56.7 / 54.9	10.2	8.6	2	2.1	98.4	13.2	0.7	0.41
6	543	(1) 1/20	0.7	80	54.9 / 53.4	15.3	12.1	3	4.8	100.9	18.3	0.9	0.96
8	620	(1) 1/10	1	114	55.1 / 53.4	17.4	13.6	3.5	6.1	100.1	20.3	1	1.22
10	821	(2) 1/20	1.1	132	54.4 / 52.8	24.4	18.7	4.9	13.5	101.4	28.1	1.4	2.87
12	848	(2) 1/20	1.2	142	54.2 / 52.8	25.2	19.5	5	5.5	103.3	30.7	1.6	3.84

**NOTE:** Based on 70°F EAT, 180°F EWT, 40°F temperature drop. Cooling coil data based on 75°F DB EAT, 63°F WB, 45°F EWT, 55°F LWT. All selections made at High speed, .05" ESP, 115 V motor, Concealed style of unit, Altitude of 0'.



## FAN PERFORMANCE DATA: FW SERIES

UNIT DATA					3 ROW CHILLED WATER COIL					
UNIT SIZE	AIRFLOW (CFM)	MOTOR (HP)	FAN AMPS (FLA)	FAN WATTS	LAT DB/WB (°F)	TOTAL CAPACITY (MBH)	SENSIBLE CAPACITY (MBH)	EWT/LWT (°F)	FLUID FLOW (GPM)	FLUID PD (FT.)
2	233	(1) 1/50	0.4	45	56.1 / 54.4	7.5	5.6	45 / 55	1.5	5.8
3	307	(1) 1/20	0.5	60	55.6 / 53.9	10.3	7.6	45 / 55	2.0	9.0
4	448	(1) 1/20	0.6	70	57.4 / 55.5	13.0	10.2	45 / 54.9	2.6	3.1
6	562	(1) 1/20	0.7	80	55.7 / 54	18.6	13.9	45 / 55	3.7	6.3
8	657	(1) 1/10	1.0	114	56.2 / 54.3	21.2	15.9	45 / 55	4.2	8.0
10	854	(2) 1/20	1.1	132	55.9 / 54.2	27.9	20.9	45 / 55	5.6	5.7
12	902	(2) 1/20	1.2	142	55.1 / 53.5	31.1	22.9	45 / 55	6.2	7.7
2	233	(1) 1/50	0.4	45	55.3 / 53.6	7.9	5.9	42 / 54.1	1.3	5.1
3	307	(1) 1/20	0.5	60	54.2 / 52.6	11.3	8.1	42 / 53.9	1.9	8.6
4	448	(1) 1/20	0.6	70	56.9 / 55	13.6	10.5	42 / 54	2.2	2.5
6	562	(1) 1/20	0.7	80	54.5 / 52.9	20.3	14.6	42 / 54.1	3.3	5.6
8	657	(1) 1/10	1.0	114	55 / 53.2	23.2	16.7	42 / 54	3.8	7.0
10	854	(2) 1/20	1.1	132	54.8 / 53.2	30.2	21.9	42 / 54	5.0	5.0
12	902	(2) 1/20	1.2	142	53.8 / 52.3	34.0	24.2	42 / 54	5.7	6.7
2	233	(1) 1/50	0.4	45	57 / 55.2	6.9	5.4	42 / 56.1	1.0	3.3
3	307	(1) 1/20	0.5	60	55.7 / 53.9	10.2	7.6	42 / 56	1.5	6.4
4	448	(1) 1/20	0.6	70	55.5 / 53.6	15.4	11.2	42 / 56	2.2	12.4
6	562	(1) 1/20	0.7	80	55.9 / 54.2	18.4	13.8	42 / 56	2.6	3.8
8	657	(1) 1/10	1.0	114	56.2 / 54.3	21.2	15.8	42 / 56	3.0	5.0
10	854	(2) 1/20	1.1	132	55 / 53.2	30.1	21.8	42 / 56	4.3	10.7
12	902	(2) 1/20	1.2	142	54 / 52.5	33.6	23.9	42 / 56	4.8	14.9
2	233	(1) 1/50	0.4	45	58.9 / 56.9	5.9	4.9	42 / 58	0.7	2.0
3	307	(1) 1/20	0.5	60	57.2 / 55.3	9.1	7.1	42 / 58.1	1.1	4.5
4	448	(1) 1/20	0.6	70	56.5 / 54.5	14.3	10.7	42 / 58	1.8	9.5
6	562	(1) 1/20	0.7	80	57.4 / 55.5	16.3	12.8	42 / 57.9	2.0	2.5
8	657	(1) 1/10	1.0	114	57.6 / 55.6	18.9	14.8	42 / 58	2.4	3.3
10	854	(2) 1/20	1.1	132	56 / 54.1	28.0	20.8	42 / 58	3.5	7.9
12	902	(2) 1/20	1.2	142	55.1 / 53.4	31.3	22.9	42 / 57.9	3.9	10.3

**NOTE:** Based on 78°F DB EAT, 65°F WB, and 3 row cooling coil. All selections made at High speed, .05" ESP, 115 V motor, Concealed style of unit, Altitude of 0'.

## FAN PERFORMANCE DATA: FW SERIES

UNIT DATA					4 ROW CHILLED WATER COIL					
UNIT SIZE	AIRFLOW (CFM)	MOTOR (HP)	FAN AMPS (FLA)	FAN WATTS	LAT DB/WB (°F)	TOTAL CAPACITY (MBH)	SENSIBLE CAPACITY (MBH)	EWT/LWT (°F)	FLUID FLOW (GPM)	FLUID PD (FT.)
2	228	(1) 1/50	0.4	45	52.7 / 51.8	8.9	6.4	45 / 55	1.8	9.2
3	297	(1) 1/20	0.5	60	54.8 / 53.9	9.9	7.6	45 / 55.1	2.0	2.4
4	426	(1) 1/20	0.6	70	53.9 / 52.8	15.4	11.4	45 / 55.1	3.0	5.2
6	543	(1) 1/20	0.7	80	52.5 / 51.6	21.5	15.4	45 / 55	4.3	10.4
8	620	(1) 1/10	1.0	114	52.8 / 51.8	24.1	17.3	45 / 55	4.8	13.4
10	821	(2) 1/20	1.1	132	53.2 / 52.2	31.2	22.5	45 / 55	6.2	8.4
12	848	(2) 1/20	1.2	142	52.3 / 51.4	33.8	24.1	45 / 55	6.7	11.1
2	228	(1) 1/50	0.4	45	51.3 / 50.4	9.7	6.7	42 / 54	1.6	8.6
3	297	(1) 1/20	0.5	60	50.6 / 49.8	13.1	9.0	42 / 54	2.2	13.6
4	426	(1) 1/20	0.6	70	52.7 / 51.7	16.7	11.9	42 / 54.1	2.8	4.6
6	543	(1) 1/20	0.7	80	50.9 / 50	23.6	16.3	42 / 54	3.9	9.1
8	620	(1) 1/10	1.0	114	51.2 / 50.3	26.6	18.4	42 / 54	4.4	11.6
10	821	(2) 1/20	1.1	132	51.7 / 50.7	34.2	23.9	42 / 54	5.7	7.4
12	848	(2) 1/20	1.2	142	50.6 / 49.8	37.3	25.7	42 / 54	6.2	9.6
2	228	(1) 1/50	0.4	45	52.8 / 51.9	8.8	6.4	42 / 56	1.3	6.4
3	297	(1) 1/20	0.5	60	51.8 / 50.9	12.3	8.6	42 / 56	1.7	10.6
4	426	(1) 1/20	0.6	70	54.4 / 53.3	14.9	11.2	42 / 56.1	2.1	3.0
6	543	(1) 1/20	0.7	80	52.1 / 51.2	22.0	15.6	42 / 56	3.1	6.7
8	620	(1) 1/10	1.0	114	52.3 / 51.3	24.9	17.6	42 / 56	3.6	8.5
10	821	(2) 1/20	1.1	132	53.1 / 52	31.5	22.7	42 / 56	4.5	5.1
12	848	(2) 1/20	1.2	142	52 / 51	34.7	24.5	42 / 56.1	4.9	6.7
2	228	(1) 1/50	0.4	45	54.4 / 53.5	7.9	6.0	42 / 58	1.0	4.4
3	297	(1) 1/20	0.5	60	53.2 / 52.2	11.2	8.2	42 / 58	1.4	8.1
4	426	(1) 1/20	0.6	70	52.8 / 51.7	16.7	11.9	42 / 58	2.1	15.0
6	543	(1) 1/20	0.7	80	53.5 / 52.5	20.1	14.8	42 / 58	2.5	4.8
8	620	(1) 1/10	1.0	114	53.7 / 52.6	22.8	16.7	42 / 58.1	2.8	6.0
10	821	(2) 1/20	1.1	132	52.5 / 51.5	32.6	23.2	42 / 58	4.1	12.9
12	848	(2) 1/20	1.2	142	53.2 / 52.3	31.9	23.3	42 / 58	4.0	4.6

**NOTE:** Based on 78°F DB EAT, 65°F WB, and 4 row cooling coil. All selections made at High speed, .05" ESP, 115 V motor, Concealed style of unit, Altitude of 0'.

UNIT DATA					3 ROW CHILLED WATER COIL					1 ROW HOT WATER COIL			
UNIT SIZE	AIRFLOW (CFM)	MOTOR (HP)	FAN AMPS (FLA)	FAN WATTS	LAT DB/WB (°F)	TOTAL CAPACITY (MBH)	SENSIBLE CAPACITY (MBH)	FLUID FLOW (GPM)	FLUID PD (FT.)	LAT DB (°F)	SENSIBLE CAPACITY (MBH)	FLUID FLOW (GPM)	FLUID PD (FT.)
2	228	(1) 1/50	0.4	45	56 / 54.4	7.3	5.5	1.5	5.7	95.3	6.3	0.3	0.12
3	297	(1) 1/20	0.5	60	55.4 / 53.7	10.1	7.4	2	8.7	97.8	9.0	0.5	0.21
4	426	(1) 1/20	0.6	70	57.3 / 55.4	12.4	9.8	2.5	2.9	98.4	13.2	0.7	0.41
6	543	(1) 1/20	0.7	80	55.4 / 53.8	18.2	13.6	3.6	6.2	100.9	18.3	0.9	0.96
8	620	(1) 1/10	1	114	55.8 / 54	20.5	15.2	4.1	7.5	100.1	20.3	1	1.22
10	821	(2) 1/20	1.1	132	55.7 / 54	27.2	20.3	5.4	5.6	101.4	28.1	1.4	2.87
12	848	(2) 1/20	1.2	142	54.8 / 53.3	29.7	21.8	5.9	6.9	103.3	30.7	1.6	3.84

**NOTE:** Based on 70°F EAT, 180°F EWT, 40°F temperature drop. Cooling coil data based on 78°F DB EAT, 65°F WB, 45°F EWT, 55°F LWT. All selections made at High speed, .05" ESP, 115 V motor, Concealed style of unit, Altitude of 0'.

## FAN PERFORMANCE DATA: FW SERIES

UNIT DATA					3 ROW CHILLED WATER COIL					
UNIT SIZE	AIRFLOW (CFM)	MOTOR (HP)	FAN AMPS (FLA)	FAN WATTS	LAT DB/WB (°F)	TOTAL CAPACITY (MBH)	SENSIBLE CAPACITY (MBH)	EWT/LWT (°F)	FLUID FLOW (GPM)	FLUID PD (FT.)
2	233	(1) 1/50	0.4	45	55.6 / 54.2	5.3	4.2	45 / 55	1.1	3.7
3	307	(1) 1/20	0.5	60	54.7 / 53.4	7.7	5.9	45 / 55	1.5	6.8
4	448	(1) 1/20	0.6	70	54.6 / 53.2	11.5	8.6	45 / 55	2.3	13.6
6	562	(1) 1/20	0.7	80	54.9 / 53.5	13.8	10.7	45 / 55	2.8	4.2
8	657	(1) 1/10	1.0	114	55.1 / 53.6	16.0	12.3	45 / 55	3.2	5.4
10	854	(2) 1/20	1.1	132	54.2 / 52.9	22.5	16.8	45 / 55	4.5	11.7
12	902	(2) 1/20	1.2	142	54.3 / 53	23.4	17.7	45 / 55	4.7	4.9
2	233	(1) 1/50	0.4	45	54.9 / 53.6	5.7	4.4	42 / 54	0.9	3.2
3	307	(1) 1/20	0.5	60	53.6 / 52.3	8.5	6.2	42 / 54	1.4	6.3
4	448	(1) 1/20	0.6	70	53.3 / 51.9	12.9	9.3	42 / 54	2.1	12.1
6	562	(1) 1/20	0.7	80	53.8 / 52.6	15.3	11.3	42 / 54	2.5	3.7
8	657	(1) 1/10	1.0	114	54.2 / 52.7	17.6	13.0	42 / 54	2.9	4.7
10	854	(2) 1/20	1.1	132	52.9 / 51.6	25.3	18.0	42 / 54	4.2	10.4
12	902	(2) 1/20	1.2	142	52.2 / 51	28.1	19.7	42 / 54	4.6	14.1
2	233	(1) 1/50	0.4	45	57.1 / 55.5	4.5	3.8	42 / 56	0.6	1.6
3	307	(1) 1/20	0.5	60	55.2 / 53.7	7.4	5.7	42 / 56	1.1	4.1
4	448	(1) 1/20	0.6	70	54.5 / 52.9	11.7	8.7	42 / 56	1.7	9.0
6	562	(1) 1/20	0.7	80	55.5 / 54.1	13.0	10.3	42 / 56	1.9	2.2
8	657	(1) 1/10	1.0	114	55.6 / 54	15.3	11.9	42 / 56	2.2	2.9
10	854	(2) 1/20	1.1	132	54.1 / 52.7	22.9	16.9	42 / 56	3.3	7.2
12	902	(2) 1/20	1.2	142	53.3 / 52.1	25.7	18.6	42 / 56.1	3.6	9.4
2	233	(1) 1/50	0.4	45	58.4 / 56.4	3.9	3.5	42 / 58	0.5	1.0
3	307	(1) 1/20	0.5	60	56.9 / 55.2	6.1	5.1	42 / 58	0.8	2.4
4	448	(1) 1/20	0.6	70	55.8 / 54.2	10.3	8.0	42 / 58.1	1.3	6.1
6	562	(1) 1/20	0.7	80	54.2 / 52.8	14.9	11.1	42 / 58	1.9	12.5
8	657	(1) 1/10	1.0	114	57.2 / 55.4	12.8	10.7	42 / 57.9	1.6	1.7
10	854	(2) 1/20	1.1	132	55.3 / 53.8	20.3	15.7	42 / 57.9	2.5	4.7
12	902	(2) 1/20	1.2	142	54.4 / 53.1	23.2	17.5	42 / 57.9	2.9	6.5

**NOTE:** Based on 72°F DB EAT, 62°F WB, and 3 row cooling coil. All selections made at High speed, .05" ESP, 115 V motor, Concealed style of unit, Altitude of 0'.

## FAN PERFORMANCE DATA: FW SERIES

UNIT DATA					4 ROW CHILLED WATER COIL					
UNIT SIZE	AIRFLOW (CFM)	MOTOR (HP)	FAN AMPS (FLA)	FAN WATTS	LAT DB/WB (°F)	TOTAL CAPACITY (MBH)	SENSIBLE CAPACITY (MBH)	EWT/LWT (°F)	FLUID FLOW (GPM)	FLUID PD (FT.)
2	228	(1) 1/50	0.4	45	52.6 / 51.9	6.6	4.9	45 / 55	1.3	6.7
3	297	(1) 1/20	0.5	60	51.9 / 51.2	9.1	6.6	45 / 55	1.8	10.7
4	426	(1) 1/20	0.6	70	53.6 / 52.8	11.3	8.7	45 / 55	2.2	3.3
6	543	(1) 1/20	0.7	80	52.1 / 51.4	16.4	12.0	45 / 55	3.3	7.2
8	620	(1) 1/10	1.0	114	52.3 / 51.5	18.6	13.5	45 / 55	3.7	8.7
10	821	(2) 1/20	1.1	132	52.8 / 52	23.6	17.4	45 / 55	4.7	5.5
12	848	(2) 1/20	1.2	142	51.9 / 51.2	26.0	18.9	45 / 54.9	5.2	7.4
2	228	(1) 1/50	0.4	45	51.2 / 50.5	7.4	5.3	42 / 53.9	1.2	6.3
3	297	(1) 1/20	0.5	60	50.3 / 49.6	10.3	7.1	42 / 54	1.7	10.5
4	426	(1) 1/20	0.6	70	52.6 / 51.9	12.3	9.1	42 / 54.1	2.0	2.9
6	543	(1) 1/20	0.7	80	50.6 / 50	18.4	12.8	42 / 54	3.0	6.6
8	620	(1) 1/10	1.0	114	50.7 / 50	20.9	14.6	42 / 54	3.5	8.4
10	821	(2) 1/20	1.1	132	51.4 / 50.6	26.3	18.7	42 / 54	4.4	4.9
12	848	(2) 1/20	1.2	142	50.5 / 49.8	29.0	20.2	42 / 54.1	4.8	6.5
2	228	(1) 1/50	0.4	45	53 / 52.3	6.4	4.8	42 / 56	0.9	3.9
3	297	(1) 1/20	0.5	60	51.8 / 51.1	9.2	6.6	42 / 56	1.3	7.5
4	426	(1) 1/20	0.6	70	51.3 / 50.5	13.8	9.7	42 / 56	2.0	13.8
6	543	(1) 1/20	0.7	80	52.1 / 51.4	16.4	11.9	42 / 56	2.3	4.2
8	620	(1) 1/10	1.0	114	52.1 / 51.3	18.8	13.6	42 / 55.9	2.7	5.6
10	821	(2) 1/20	1.1	132	51.1 / 50.3	27.0	19.0	42 / 56	3.8	11.9
12	848	(2) 1/20	1.2	142	51.9 / 51.2	26.1	18.9	42 / 56	3.7	4.1
2	228	(1) 1/50	0.4	45	55 / 54.1	5.2	4.3	42 / 57.9	0.7	2.3
3	297	(1) 1/20	0.5	60	53.3 / 52.5	8.1	6.1	42 / 57.9	1.0	5.1
4	426	(1) 1/20	0.6	70	52.6 / 51.7	12.5	9.2	42 / 58	1.6	10.9
6	543	(1) 1/20	0.7	80	53.7 / 52.9	14.3	11.0	42 / 58	1.8	2.7
8	620	(1) 1/10	1.0	114	53.7 / 52.8	16.4	12.5	42 / 58	2.0	3.5
10	821	(2) 1/20	1.1	132	52.3 / 51.5	24.5	17.9	42 / 58	3.0	8.5
12	848	(2) 1/20	1.2	142	51.5 / 50.8	26.9	19.2	42 / 58	3.3	11.1

**NOTE:** Based on 72°F DB EAT, 62°F WB, and 4 row cooling coil. All selections made at High speed, .05" ESP, 115 V motor, Concealed style of unit, Altitude of 0'.

UNIT DATA					3 ROW CHILLED WATER COIL					1 ROW HOT WATER COIL			
UNIT SIZE	AIRFLOW (CFM)	MOTOR (HP)	FAN AMPS (FLA)	FAN WATTS	LAT DB/WB (°F)	TOTAL CAPACITY (MBH)	SENSIBLE CAPACITY (MBH)	FLUID FLOW (GPM)	FLUID PD (FT.)	LAT DB (°F)	SENSIBLE CAPACITY (MBH)	FLUID FLOW (GPM)	FLUID PD (FT.)
2	228	(1) 1/50	0.4	45	55.4 / 54.1	5.3	4.2	1.1	3.7	95.3	6.3	0.3	0.12
3	297	(1) 1/20	0.5	60	54.6 / 53.3	7.5	5.7	1.5	6.6	97.8	9.0	0.5	0.21
4	426	(1) 1/20	0.6	70	54.4 / 53	11.1	8.3	2.2	12.8	98.4	13.2	0.7	0.41
6	543	(1) 1/20	0.7	80	54.7 / 53.4	13.5	10.4	2.7	4.0	100.9	18.3	0.9	0.96
8	620	(1) 1/10	1	114	54.9 / 53.5	15.3	11.7	3	5.0	100.1	20.3	1	1.22
10	821	(2) 1/20	1.1	132	54.1 / 52.8	21.9	16.3	4.4	11.0	101.4	28.1	1.4	2.87
12	848	(2) 1/20	1.2	142	53.3 / 52.1	24.0	17.5	4.8	14.8	103.3	30.7	1.6	3.84

**NOTE:** Based on 70°F EAT, 180°F EWT, 40°F temperature drop. Cooling coil data based on 72°F DB EAT, 62°F WB, 45°F EWT, 55°F LWT. All selections made at High speed, .05" ESP, 115 V motor, Concealed style of unit, Altitude of 0'.

## FAN PERFORMANCE DATA: FL SERIES

UNIT DATA					3 ROW CHILLED WATER COIL					
UNIT SIZE	AIRFLOW (CFM)	MOTOR (HP)	FAN AMPS (FLA)	FAN WATTS	LAT DB/WB (°F)	TOTAL CAPACITY (MBH)	SENSIBLE CAPACITY (MBH)	EWT/LWT (°F)	FLUID FLOW (GPM)	FLUID PD (FT.)
02	236	(1) 1/25	0.6	65	54.2 / 52.8	7.0	5.4	45 / 55.1	1.4	5.8
03	336	(1) 1/25	0.6	62	56.6 / 55	8.0	6.8	45 / 54.9	1.6	1.4
04	452	(1) 1/25	0.6	62	55.1 / 53.6	12.4	10.0	45 / 55	2.5	3.2
06	615	(2) 1/25	1.2	127	53.7 / 52.4	19.0	14.5	45 / 55	3.8	7.8
02	236	(1) 1/25	0.6	65	53 / 51.7	7.7	5.7	42 / 54	1.3	5.3
03	336	(1) 1/25	0.6	62	56.7 / 55.1	7.9	6.8	42 / 54.1	1.3	1.0
04	452	(1) 1/25	0.6	62	54.1 / 52.7	13.5	10.4	42 / 54	2.2	2.8
06	615	(2) 1/25	1.2	127	52.3 / 51	21.1	15.4	42 / 54	3.5	7.3
02	236	(1) 1/25	0.6	65	54.6 / 53.2	6.8	5.3	42 / 56	1.0	3.4
03	336	(1) 1/25	0.6	62	58.7 / 56.6	6.5	6.0	42 / 56	0.9	0.5
04	452	(1) 1/25	0.6	62	55.8 / 54.2	11.7	9.6	42 / 55.9	1.7	1.7
06	615	(2) 1/25	1.2	127	53.5 / 52.2	19.3	14.6	42 / 55.9	2.8	4.9
02	236	(1) 1/25	0.6	65	56.4 / 54.8	5.7	4.8	42 / 58	0.7	2.1
03	336	(1) 1/25	0.6	62	59.4 / 57	6.1	5.8	42 / 58	0.8	0.4
04	452	(1) 1/25	0.6	62	58.2 / 56.1	9.3	8.4	42 / 58	1.2	0.9
06	615	(2) 1/25	1.2	127	54.9 / 53.5	17.2	13.6	42 / 58	2.1	3.2

UNIT DATA					4 ROW CHILLED WATER COIL					
UNIT SIZE	AIRFLOW (CFM)	MOTOR (HP)	FAN AMPS (FLA)	FAN WATTS	LAT DB/WB (°F)	TOTAL CAPACITY (MBH)	SENSIBLE CAPACITY (MBH)	EWT/LWT (°F)	FLUID FLOW (GPM)	FLUID PD (FT.)
02	230	(1) 1/25	0.6	65	51.2 / 50.5	8.2	6.1	45 / 55	1.6	9.4
03	328	(1) 1/25	0.6	62	53.2 / 52.5	10.0	7.9	45 / 55	2.0	2.7
04	438	(1) 1/25	0.6	62	54.4 / 53.6	12.1	10.0	45 / 55.1	2.4	1.3
06	602	(2) 1/25	1.2	127	52.4 / 51.6	19.7	15.0	45 / 55	3.9	3.7
02	230	(1) 1/25	0.6	65	49.5 / 48.9	9.1	6.5	42 / 53.9	1.5	9.0
03	328	(1) 1/25	0.6	62	52.2 / 51.5	10.9	8.3	42 / 53.9	1.8	2.3
04	438	(1) 1/25	0.6	62	53.8 / 53	12.8	10.2	42 / 54	2.1	1.1
06	602	(2) 1/25	1.2	127	51.1 / 50.3	21.7	15.9	42 / 54	3.6	3.2
02	230	(1) 1/25	0.6	65	51 / 50.4	8.3	6.1	42 / 56	1.2	6.3
03	328	(1) 1/25	0.6	62	54.6 / 53.7	9.0	7.4	42 / 56	1.3	1.2
04	438	(1) 1/25	0.6	62	56.8 / 55.5	9.7	8.8	42 / 56	1.4	0.5
06	602	(2) 1/25	1.2	127	52.7 / 52	19.2	14.8	42 / 56	2.7	2.0
02	230	(1) 1/25	0.6	65	52.5 / 51.8	7.4	5.7	42 / 58	0.9	4.3
03	328	(1) 1/25	0.6	62	56.6 / 55.4	7.4	6.7	42 / 58	0.9	0.7
04	438	(1) 1/25	0.6	62	57.5 / 56	9.2	8.4	42 / 58	1.1	0.3
06	602	(2) 1/25	1.2	127	54.5 / 53.6	16.6	13.6	42 / 58	2.1	1.2

**NOTE:** Based on 75°F DB EAT, 63°F WB. All selections made at High speed, .05" ESP, 115 V motor, Concealed style of unit, Altitude of 0'.

UNIT DATA					3 ROW CHILLED WATER COIL					1 ROW HOT WATER COIL			
UNIT SIZE	AIRFLOW (CFM)	MOTOR (HP)	FAN AMPS (FLA)	FAN WATTS	LAT DB/WB (°F)	TOTAL CAPACITY (MBH)	SENSIBLE CAPACITY (MBH)	FLUID FLOW (GPM)	FLUID PD (FT.)	LAT DB (°F)	SENSIBLE CAPACITY (MBH)	FLUID FLOW (GPM)	FLUID PD (FT.)
02	230	(1) 1/25	0.6	65	54 / 52.7	6.9	5.4	1.4	5.8	99.4	7.3	0.4	0.16
03	328	(1) 1/25	0.6	62	56.7 / 55.1	7.7	6.6	1.5	1.3	100.4	10.8	0.6	0.29
04	438	(1) 1/25	0.6	62	55 / 53.6	12.1	9.7	2.4	3.1	101.7	15.1	0.8	0.62
06	602	(2) 1/25	1.2	127	53.5 / 52.2	18.8	14.3	3.8	7.8	103.7	22.1	1.1	1.66

**NOTE:** Based on 70°F EAT, 180°F EWT, 40°F temperature drop. Cooling coil data based on 75°F DB EAT, 63°F WB, 45°F EWT, 55°F LWT. All selections made at High speed, .05" ESP, 115 V motor, Concealed style of unit, Altitude of 0'.

## FAN PERFORMANCE DATA: FL SERIES

UNIT DATA					3 ROW CHILLED WATER COIL					
UNIT SIZE	AIRFLOW (CFM)	MOTOR (HP)	FAN AMPS (FLA)	FAN WATTS	LAT DB/WB (°F)	TOTAL CAPACITY (MBH)	SENSIBLE CAPACITY (MBH)	EWT/LWT (°F)	FLUID FLOW (GPM)	FLUID PD (FT.)
02	236	(1) 1/25	0.6	65	54.4 / 53.1	8.4	6.2	45 / 55	1.7	7.2
03	336	(1) 1/25	0.6	62	57 / 55.4	9.8	7.8	45 / 55	2.0	1.9
04	452	(1) 1/25	0.6	62	55.5 / 54	15.0	11.3	45 / 55	3.0	4.3
06	615	(2) 1/25	1.2	127	54.2 / 52.8	22.3	16.2	45 / 55	4.4	10.2
02	236	(1) 1/25	0.6	65	53.2 / 51.9	9.1	6.5	42 / 53.9	1.5	6.7
03	336	(1) 1/25	0.6	62	56.6 / 55.1	10.1	7.9	42 / 54.1	1.7	1.5
04	452	(1) 1/25	0.6	62	54.5 / 53	16.2	11.8	42 / 54	2.7	3.7
06	615	(2) 1/25	1.2	127	52.8 / 51.4	24.5	17.2	42 / 54	4.1	8.7
02	236	(1) 1/25	0.6	65	54.8 / 53.4	8.2	6.1	42 / 56	1.2	4.6
03	336	(1) 1/25	0.6	62	59.6 / 57.6	7.7	6.8	42 / 56.1	1.1	0.7
04	452	(1) 1/25	0.6	62	56.1 / 54.6	14.3	11.0	42 / 56	2.0	2.4
06	615	(2) 1/25	1.2	127	53.9 / 52.5	22.8	16.4	42 / 55.9	3.3	6.5
02	236	(1) 1/25	0.6	65	56.5 / 55	7.2	5.6	42 / 58	0.9	3.0
03	336	(1) 1/25	0.6	62	60.6 / 58.3	7.0	6.4	42 / 58	0.9	0.5
04	452	(1) 1/25	0.6	62	57.9 / 56.2	12.2	10.0	42 / 58	1.5	1.4
06	615	(2) 1/25	1.2	127	55.3 / 53.8	20.7	15.5	42 / 58	2.6	4.4

UNIT DATA					4 ROW CHILLED WATER COIL					
UNIT SIZE	AIRFLOW (CFM)	MOTOR (HP)	FAN AMPS (FLA)	FAN WATTS	LAT DB/WB (°F)	TOTAL CAPACITY (MBH)	SENSIBLE CAPACITY (MBH)	EWT/LWT (°F)	FLUID FLOW (GPM)	FLUID PD (FT.)
02	230	(1) 1/25	0.6	65	51.3 / 50.7	9.6	6.8	45 / 55	1.9	10.6
03	328	(1) 1/25	0.6	62	53.4 / 52.6	12.1	8.9	45 / 55	2.4	3.5
04	438	(1) 1/25	0.6	62	54.4 / 53.6	15.0	11.4	45 / 55	3.0	1.9
06	602	(2) 1/25	1.2	127	52.6 / 51.7	23.5	17.0	45 / 55	4.7	5.0
02	230	(1) 1/25	0.6	65	49.6 / 49	10.6	7.2	42 / 54.1	1.7	10.4
03	328	(1) 1/25	0.6	62	52.2 / 51.5	13.1	9.4	42 / 53.9	2.2	3.1
04	438	(1) 1/25	0.6	62	53.7 / 52.9	15.8	11.8	42 / 54	2.6	1.5
06	602	(2) 1/25	1.2	127	51.2 / 50.4	25.6	17.9	42 / 54	4.2	4.3
02	230	(1) 1/25	0.6	65	51 / 50.3	9.8	6.9	42 / 56	1.4	7.9
03	328	(1) 1/25	0.6	62	54.3 / 53.5	11.3	8.6	42 / 56.1	1.6	1.8
04	438	(1) 1/25	0.6	62	56.2 / 55.2	13.0	10.6	42 / 56	1.9	0.8
06	602	(2) 1/25	1.2	127	52.7 / 51.9	23.3	16.9	42 / 56	3.3	2.8
02	230	(1) 1/25	0.6	65	52.4 / 51.7	9.0	6.5	42 / 57.9	1.1	5.8
03	328	(1) 1/25	0.6	62	56.7 / 55.7	9.3	7.7	42 / 58	1.2	1.0
04	438	(1) 1/25	0.6	62	58.6 / 57.2	10.5	9.4	42 / 58	1.3	0.4
06	602	(2) 1/25	1.2	127	54.4 / 53.6	20.6	15.7	42 / 58	2.6	1.8

**NOTE:** Based on 78°F DB EAT, 65°F WB. All selections made at High speed, .05" ESP, 115 V motor, Concealed style of unit, Altitude of 0'.

UNIT DATA					3 ROW CHILLED WATER COIL					1 ROW HOT WATER COIL			
UNIT SIZE	AIRFLOW (CFM)	MOTOR (HP)	FAN AMPS (FLA)	FAN WATTS	LAT DB/WB (°F)	TOTAL CAPACITY (MBH)	SENSIBLE CAPACITY (MBH)	FLUID FLOW (GPM)	FLUID PD (FT.)	LAT DB (°F)	SENSIBLE CAPACITY (MBH)	FLUID FLOW (GPM)	FLUID PD (FT.)
02	230	(1) 1/25	0.6	65	54.3 / 53	8.2	6.0	1.6	7.1	99.4	7.3	0.4	0.16
03	328	(1) 1/25	0.6	62	56.8 / 55.3	9.7	7.7	1.9	1.9	100.4	10.8	0.6	0.29
04	438	(1) 1/25	0.6	62	55.4 / 53.9	14.7	11.0	2.9	4.1	101.7	15.1	0.8	0.62
06	602	(2) 1/25	1.2	127	54.1 / 52.8	22.0	15.9	4.4	9.9	103.7	22.1	1.1	1.66

**NOTE:** Based on 70°F EAT, 180°F EWT, 40°F temperature drop. Cooling coil data based on 78°F DB EAT, 65°F WB, 45°F EWT, 55°F LWT. All selections made at High speed, .05" ESP, 115 V motor, Concealed style of unit.

# FAN PERFORMANCE DATA: FL SERIES

UNIT DATA					3 ROW CHILLED WATER COIL					
UNIT SIZE	AIRFLOW (CFM)	MOTOR (HP)	FAN AMPS (FLA)	FAN WATTS	LAT DB/WB (°F)	TOTAL CAPACITY (MBH)	SENSIBLE CAPACITY (MBH)	EWT/LWT (°F)	FLUID FLOW (GPM)	FLUID PD (FT.)
02	236	(1) 1/25	0.6	65	54 / 52.9	6.2	4.7	45 / 55	1.2	5.0
03	336	(1) 1/25	0.6	62	56.8 / 55.4	6.5	5.6	45 / 54.9	1.3	1.0
04	452	(1) 1/25	0.6	62	54.9 / 53.7	10.9	8.5	45 / 55	2.2	2.6
06	615	(2) 1/25	1.2	127	53.5 / 52.4	16.9	12.6	45 / 55.1	3.3	6.7
02	236	(1) 1/25	0.6	65	53 / 51.9	6.8	5.0	42 / 54	1.1	4.4
03	336	(1) 1/25	0.6	62	57.4 / 55.8	6.1	5.4	42 / 54	1.0	0.6
04	452	(1) 1/25	0.6	62	54.1 / 53	11.8	8.9	42 / 54	2.0	2.2
06	615	(2) 1/25	1.2	127	52.2 / 51.2	18.9	13.5	42 / 54.1	3.1	6.1
02	236	(1) 1/25	0.6	65	54.8 / 53.6	5.7	4.5	42 / 56	0.8	2.6
03	336	(1) 1/25	0.6	62	58 / 56.2	5.8	5.2	42 / 56	0.8	0.4
04	452	(1) 1/25	0.6	62	56.2 / 54.9	9.5	7.9	42 / 56	1.3	1.1
06	615	(2) 1/25	1.2	127	53.6 / 52.5	16.9	12.5	42 / 56	2.4	3.9
02	236	(1) 1/25	0.6	65	57.2 / 55.7	4.4	3.8	42 / 58	0.5	1.3
03	336	(1) 1/25	0.6	62	58.8 / 56.8	5.3	4.9	42 / 58.1	0.7	0.3
04	452	(1) 1/25	0.6	62	58.7 / 56.7	7.1	6.6	42 / 58	0.9	0.5
06	615	(2) 1/25	1.2	127	55.1 / 53.9	14.6	11.5	42 / 58	1.8	2.4

UNIT DATA					4 ROW CHILLED WATER COIL					
UNIT SIZE	AIRFLOW (CFM)	MOTOR (HP)	FAN AMPS (FLA)	FAN WATTS	LAT DB/WB (°F)	TOTAL CAPACITY (MBH)	SENSIBLE CAPACITY (MBH)	EWT/LWT (°F)	FLUID FLOW (GPM)	FLUID PD (FT.)
02	230	(1) 1/25	0.6	65	51.3 / 50.8	7.3	5.3	45 / 55	1.5	8.3
03	328	(1) 1/25	0.6	62	53.4 / 52.8	8.7	6.7	45 / 55	1.7	2.1
04	438	(1) 1/25	0.6	62	54.6 / 53.9	10.3	8.4	45 / 54.9	2.1	1.0
06	602	(2) 1/25	1.2	127	52.5 / 51.8	17.5	13.0	45 / 55	3.5	3.1
02	230	(1) 1/25	0.6	65	49.6 / 49.1	8.3	5.7	42 / 53.9	1.4	7.9
03	328	(1) 1/25	0.6	62	52.8 / 52.2	9.3	7.0	42 / 54.1	1.5	1.7
04	438	(1) 1/25	0.6	62	54.5 / 53.8	10.5	8.5	42 / 53.9	1.7	0.7
06	602	(2) 1/25	1.2	127	51.2 / 50.6	19.4	13.8	42 / 54	3.2	2.7
02	230	(1) 1/25	0.6	65	51.2 / 50.7	7.4	5.3	42 / 55.9	1.1	5.3
03	328	(1) 1/25	0.6	62	55.5 / 54.7	7.0	6.0	42 / 56	1.0	0.8
04	438	(1) 1/25	0.6	62	56.3 / 55.3	8.6	7.6	42 / 56	1.2	0.4
06	602	(2) 1/25	1.2	127	53.1 / 52.5	16.5	12.6	42 / 56	2.3	1.5
02	230	(1) 1/25	0.6	65	53.1 / 52.5	6.3	4.8	42 / 58	0.8	3.2
03	328	(1) 1/25	0.6	62	56.2 / 55.2	6.6	5.7	42 / 58	0.8	0.5
04	438	(1) 1/25	0.6	62	57.1 / 55.8	8.0	7.2	42 / 58	1.0	0.3
06	602	(2) 1/25	1.2	127	55.5 / 54.6	13.1	11.0	42 / 58	1.6	0.8

**NOTE:** Based on 72°F DB EAT, 62°F WB. All selections made at High speed, .05" ESP, 115 V motor, Concealed style of unit.

UNIT DATA					3 ROW CHILLED WATER COIL					1 ROW HOT WATER COIL			
UNIT SIZE	AIRFLOW (CFM)	MOTOR (HP)	FAN AMPS (FLA)	FAN WATTS	LAT DB/WB (°F)	TOTAL CAPACITY (MBH)	SENSIBLE CAPACITY (MBH)	FLUID FLOW (GPM)	FLUID PD (FT.)	LAT DB (°F)	SENSIBLE CAPACITY (MBH)	FLUID FLOW (GPM)	FLUID PD (FT.)
02	230	(1) 1/25	0.6	65	54 / 52.9	6.03	4.6	1.2	4.8	99.4	7.3	0.4	0.16
03	328	(1) 1/25	0.6	62	57 / 55.6	6.22	5.4	1.2	0.9	100.4	10.8	0.6	0.29
04	438	(1) 1/25	0.6	62	54.8 / 53.7	10.59	8.3	2.1	2.5	101.7	15.1	0.8	0.62
06	602	(2) 1/25	1.2	127	53.4 / 52.3	16.75	12.4	3.3	6.7	103.7	22.1	1.1	1.66

**NOTE:** Based on 70°F EAT, 180°F EWT, 40°F temperature drop. Cooling coil data based on 72°F DB EAT, 62°F WB, 45°F EWT, 55°F LWT. All selections made at High speed, .05" ESP, 115 V motor, Concealed style of unit, Altitude of 0'.

## MOTOR AND FAN DATA

### FW MOTOR AND FAN DATA

UNIT SIZE	FAN SPEED	MOTOR H.P. (QTY.)	# OF FANS	115 VOLTS		208-230 VOLTS		277 VOLTS	
				AMPS	WATTS	AMPS	WATTS	AMPS	WATTS
02	High	(1) 1/50	1	0.40	45	0.23	53	0.21	57
	Medium			0.31	35	0.2	41	0.19	44
	Low			0.27	28	0.18	36	0.18	40
03	High	(1) 1/20	1	0.55	60	0.33	67	0.31	73
	Medium			0.43	48	0.27	54	0.26	60
	Low			0.40	43	0.25	49	0.24	54
04	High	(1) 1/20	2	0.62	70	0.30	71	0.27	76
	Medium			0.56	61	0.24	60	0.21	65
	Low			0.54	58	0.21	52	0.20	58
06	High	(1) 1/20	2	0.71	80	0.35	81	0.30	87
	Medium			0.66	74	0.29	71	0.26	77
	Low			0.59	61	0.25	59	0.22	64
08	High	(1) 1/10	2	1.03	114	0.46	109	0.40	114
	Medium			0.77	81	0.32	77	0.28	80
	Low			0.70	71	0.29	66	0.25	70
10	High	(2) 1/20	4	1.18	132	0.60	140	0.53	144
	Medium			1.03	114	0.49	116	0.42	120
	Low			0.99	107	0.43	101	0.37	106
12	High	(2) 1/20	4	1.26	142	0.63	147	0.57	154
	Medium			1.14	126	0.53	125	0.45	131
	Low			1.08	114	0.46	107	0.40	114

#### NOTES:

1. FWX, 3-row coil, no EH, no toe kick, standard throw away panel filter.
2. Data was taken without ductwork.
3. Unit size 04, 06, 08, 10 and 12 data generated at 115v, 230v and 277v.
4. Unit size 02 & 03 data generated with 115v, 240v to 120v transformer(230v line voltage) and 277v to 120v transformer (277v line voltage).
5. For FLA use unit voltage, and size at high speed.

### FL MOTOR AND FAN DATA

UNIT SIZE	FAN SPEED	MOTOR H.P. (QTY.)	# OF FANS	115 VOLTS		208-230 VOLTS		277 VOLTS	
				AMPS	WATTS	AMPS	WATTS	AMPS	WATTS
02	High	1/25	1	0.6	65.0	0.3	70.0	0.3	81.0
	Medium	1/50		0.3	42.0	0.2	43.0	0.2	50.0
	Low	1/100		0.3	28.0	0.2	29.0	0.2	34.0
03	High	1/25	2	0.6	62.0	0.3	65.0	0.3	68.0
	Medium	1/50		0.3	30.0	0.2	37.0	0.2	42.0
	Low	1/100		0.3	25.0	0.2	26.0	0.2	29.0
04	High	1/25	2	0.6	62.0	0.3	65.0	0.3	68.0
	Medium	1/50		0.3	30.0	0.2	37.0	0.2	42.0
	Low	1/100		0.3	25.0	0.2	26.0	0.2	29.0
06	High	2 @ 1/25	3	1.2	127.0	0.6	135.0	0.6	149.0
	Medium	2 @ 1/50		0.6	72.0	0.4	80.0	0.4	92.0
	Low	2 @ 1/100		0.6	53.0	0.4	55.0	0.4	63.0

#### NOTES:

1. See notes 1 and 2 above.



# SOUND DATA

## FW SOUND DATA

UNIT SIZE	FAN SPEED	SCFM	TOTAL SOUND POWER LEVEL						
			OCTAVE BAND / CENTER FREQUENCY (HZ)						
			125	250	500	1000	2000	4000	8000
02	High	233	58	63	60	53	48	43	35
	Medium	190	48	52	46	43	34	25	26
	Low	149	42	45	31	28	20	23	26
03	High	321	57	60	55	52	47	41	34
	Medium	280	54	56	52	48	42	35	28
	Low	246	49	52	47	43	36	27	27
04	High	457	59	62	63	55	48	44	36
	Medium	420	56	58	59	51	44	38	30
	Low	334	49	55	48	41	32	25	28
06	High	570	59	61	67	54	47	42	33
	Medium	492	55	58	65	50	42	36	28
	Low	362	48	62	48	39	29	23	26
08	High	633	65	67	64	58	52	48	41
	Medium	549	61	62	62	54	47	42	35
	Low	436	57	55	55	46	37	30	28
10	High	836	61	63	68	58	51	46	37
	Medium	792	59	62	67	56	49	43	35
	Low	697	55	57	65	51	43	37	29
12	High	978	62	64	65	56	50	44	35
	Medium	888	60	62	65	54	47	41	32
	Low	697	54	56	60	46	38	30	27

**NOTES:**

1. Sound data tested in accordance with ARI-350-2008.
2. Sound levels expressed in decibels, dB RE: 1 x 10<sup>-12</sup> watts.
3. Total sound power level data based on exposed cabinet model with fan CFM at corresponding motor tap with 115/1/60 volt motor, 3 row coil, 1" throwaway filter, 0.0" external static pressure and standard rated internal pressure losses.

## FL SOUND DATA

UNIT SIZE	FAN SPEED	SCFM	TOTAL SOUND POWER LEVEL						
			OCTAVE BAND / CENTER FREQUENCY (HZ)						
			2/125	3/250	4/500	5/1000	6/2000	7/4000	8/8000
02	High	250	57	64	59	57	52	52	42
	Medium	185	51	58	52	49	47	43	31
	Low	140	47	51	45	42	40	32	26
03	High	360	59	59	57	53	47	41	36
	Medium	300	52	56	53	48	43	36	34
	Low	250	51	49	46	40	33	27	25
04	High	485	54	60	56	52	48	43	37
	Medium	365	50	54	49	45	40	33	31
	Low	255	43	47	40	37	31	23	25
06	High	675	59	64	59	58	53	47	43
	Medium	500	53	57	54	49	44	37	32
	Low	375	47	52	46	40	34	25	24

**NOTES:**

1. Sound data tested in accordance with ARI 350-2000.
2. Sound levels are expressed in decibels, dB RE: 1 x 10<sup>-12</sup> Watts.
3. Total sound power level data based on both exposed cabinet and concealed models with fan CFM at corresponding motor tap with 115/1/60 Volt motor, 3 row coil, 1" throwaway filter, 0.0" external static pressure and standard rated internal pressure losses.

# DIMENSIONAL DATA: FW SERIES

## MODEL FWC CONCEALED UNIT

Drawings are not to scale and not for submittal or installation purposes. [View drawing online.](#)

**NOTES:**

1. All dimensions are in inches [millimeters]. All dimensions are  $\pm 1/4"$  [6mm]. Metric values are soft conversion.
2. Junction box size and location varies w/unit features. Control options may be limited. Provide sufficient clearance to access electrical controls and comply w/applicable codes and ordinances. Reduced height control enclosure is standard with opposite end coils.
3. Right hand coil connection shown. Left hand unit similar but opposite.
4. Some piping package options may require extended drain pans.
5. Size 02 and 03 Models with 208/230vac or 277vac have 3 5/8" [92] extended control enclosure.

DIMENSIONS			
UNIT SIZE	A	B	C
02	23 3/16 [589]	22 3/4 [578]	16" [406]
03	27 3/16 [691]	26 3/4 [679]	20" [508]
04	33 3/16 [843]	32 3/4 [832]	26" [660]
06	43 3/16 [1097]	42 3/4 [1086]	36" [914]
08	45 3/16 [1148]	44 3/4 [1137]	38" [965]
10	59 3/16 [1503]	58 3/4 [1492]	52" [1320]
12	67 3/16 [1707]	66 3/4 [1695]	60" [1524]

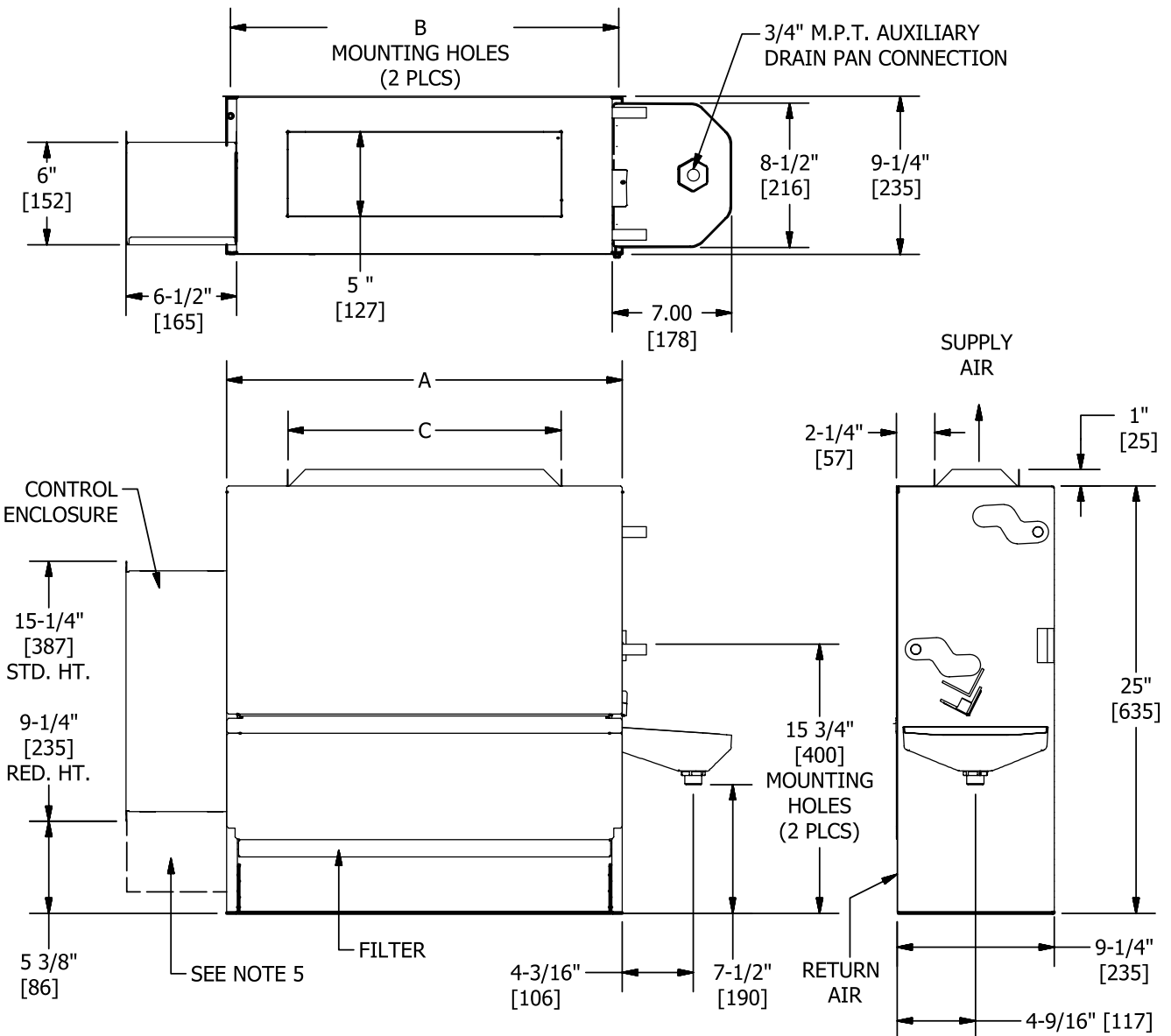

# DIMENSIONAL DATA: FW SERIES

## MODEL FWX EXPOSED UNIT

Drawings are not to scale and not for submittal or installation purposes. [View drawing online.](#)

**NOTES:**

1. All dimensions are Inches [millimeters]. All dimensions are  $\pm 1/4"$  [6mm]. Metric values are soft conversion.
2. Junction box size and location varies with unit features. Control options may be limited. Provide sufficient clearance to access electrical controls and comply with applicable codes and ordinances.
3. Standard cabinet finish is "Pearl White Satin".
4. Parametric design available to increase Height or Width. (See parametric offerings drawing.)
5. Some control or piping package options may require extended end pockets and/or extended drain pans. (See extended end pocket drawing.)
6. False back extension available.

UNIT SIZE	DIM A	DIM B	DIM C	DIM D
02	41 [1041]	22 [559]	19 1/2 [495]	22 3/4 [578]
03	45 [1143]	26 [660]	23 1/2 [597]	26 3/4 [679]
04	51 [1295]	32 [813]	27 1/2 [699]	32 3/4 [832]
06	61 [1549]	42 [1067]	39 1/2 [1003]	42 3/4 [1086]
08	63 [1600]	44 [1118]	39 1/2 [1003]	44 3/4 [1137]
10	77 [1956]	58 [1473]	55 1/2 [1410]	58 3/4 [1492]
12	85 [2159]	66 [1676]	63 1/2 [1613]	66 3/4 [1695]

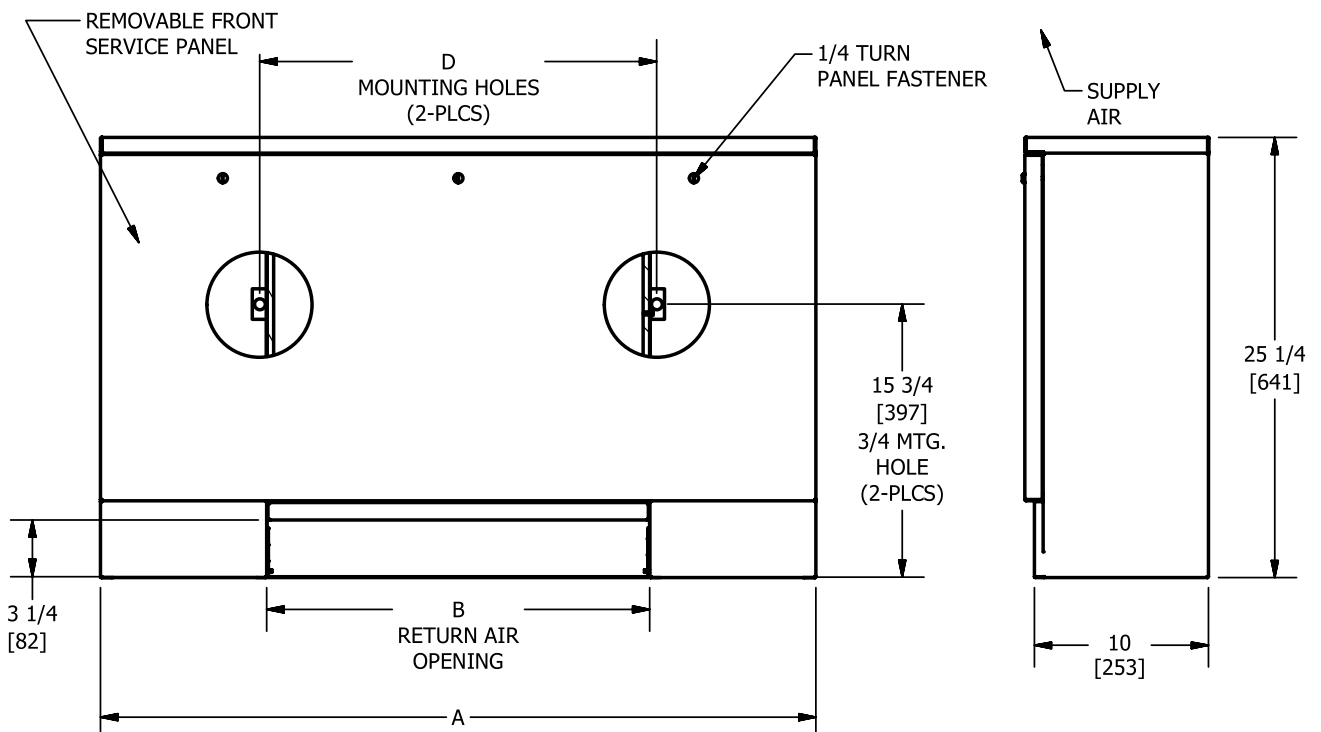
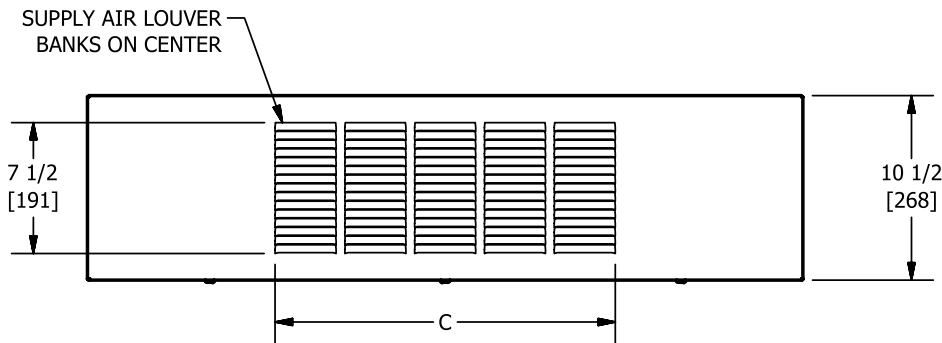

# DIMENSIONAL DATA: FW SERIES

## MODEL FWI SLOPE TOP UNIT

Drawings are not to scale and not for submittal or installation purposes. [View drawing online.](#)

**NOTES:**

1. All dimensions are Inches [millimeters]. All dimensions are  $\pm 1/4$ " [6mm]. Metric values are soft conversion.
2. Junction box size and location varies with unit features. Control options may be limited. Provide sufficient clearance to access electrical controls and comply with applicable codes and ordinances.
3. Standard cabinet finish is "Pearl White Satin".
4. Right hand unit shown, left hand unit similar, but opposite.
5. Parametric design available to increase Height or Width. (See parametric offerings drawing.)
6. Some control or piping package options may require extended end pockets and/or extended drain pans. (See extended end pocket drawing.)
7. False back extension available.

UNIT SIZE	DIM A	DIM B	DIM C	DIM D
02	41 [1041]	22 [559]	19 1/2 [495]	22 3/4 [578]
03	45 [1143]	26 [660]	23 1/2 [597]	26 3/4 [679]
04	51 [1295]	32 [813]	27 1/2 [699]	32 3/4 [832]
06	61 [1549]	42 [1067]	39 1/2 [1003]	42 3/4 [1086]
08	63 [1600]	44 [1118]	39 1/2 [1003]	44 3/4 [1137]
10	77 [1956]	58 [1473]	55 1/2 [1410]	58 3/4 [1492]
12	85 [2159]	66 [1676]	63 1/2 [1613]	66 3/4 [1695]

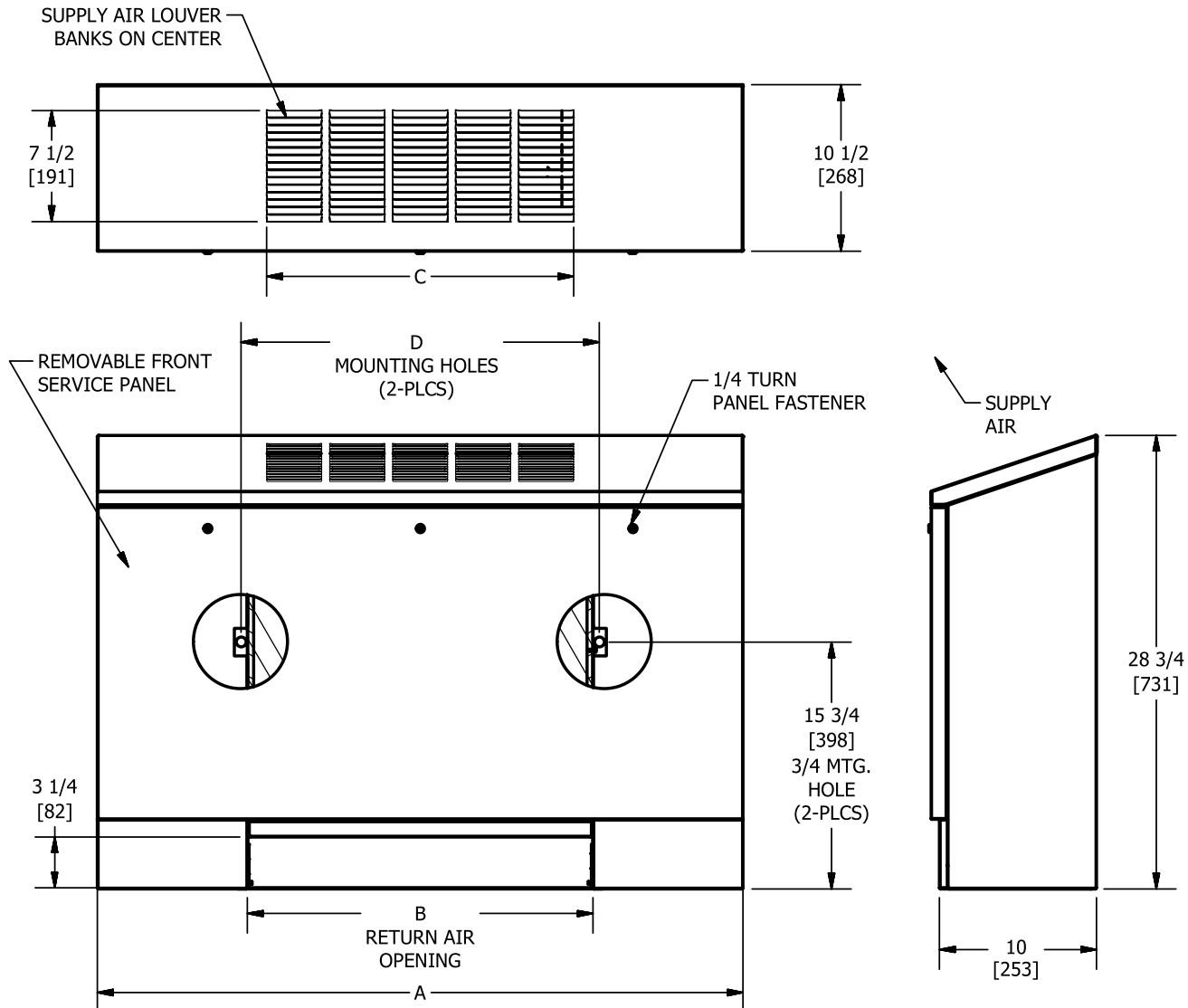

# DIMENSIONAL DATA: FW SERIES

## MODEL FWI PARAMETRIC INCREMENTS

[View drawing online](#)

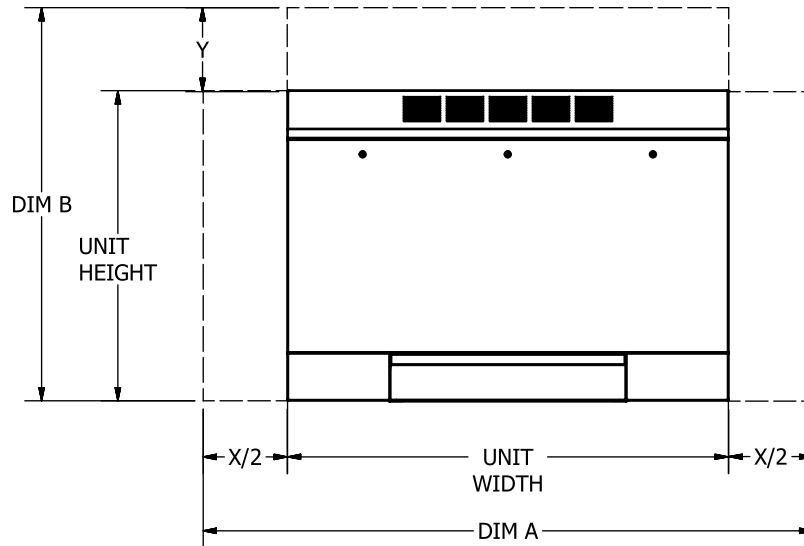

DIMENSION A (inches)													
SIZE	X=0	X=1	X=2	X=3	X=4	X=5	X=6	X=7	X=8	X=9	X=10	X=11	X=12
02	41	42	43	44	45	46	47	48	49	50	51	52	53
03	45	46	47	48	49	50	51	52	53	54	55	56	57
04	51	52	53	54	55	56	57	58	59	60	61	62	63
06	61	62	63	64	65	66	67	68	69	70	71	72	73
08	63	64	65	66	67	68	69	70	71	72	73	74	75
10	77	78	79	80	81	82	83	84	85	86	87	88	89
12	85	86	87	88	89	90	91	92	93	94	95	N/A	N/A
DIMENSION B (inches)													
ALL SIZES	Y=0	Y=1	Y=2	Y=3	Y=4	Y=5	Y=6	Y=7	Y=8	Y=9	Y=10	Y=11	Y=12
	28 3/4	29 3/4	30 3/4	31 3/4	32 3/4	33 3/4	34 3/4	35 3/4	36 3/4	37 3/4	38 3/4	39 3/4	40 3/4

DIMENSION A (millimeters)													
SIZE	X=0	X=25	X=51	X=76	X=102	X=127	X=152	X=178	X=203	X=229	X=254	X=279	X=305
02	1041	1067	1092	1118	1143	1168	1194	1219	1245	1270	1295	1321	1346
03	1143	1168	1194	1219	1245	1270	1295	1321	1346	1372	1397	1422	1448
04	1295	1321	1346	1372	1397	1422	1448	1473	1499	1524	1549	1575	1600
06	1549	1575	1600	1626	1651	1676	1702	1727	1753	1778	1803	1829	1854
08	1600	1626	1651	1676	1702	1727	1753	1778	1803	1829	1854	1880	1905
10	1956	1981	2007	2032	2057	2083	2108	2134	2159	2184	2210	2235	2261
12	2159	2184	2210	2235	2261	2286	2311	2337	2362	2388	2413	N/A	N/A
DIMENSION B (millimeters)													
ALL SIZES	Y=0	Y=25	Y=51	Y=76	Y=102	Y=127	Y=152	Y=178	Y=203	Y=229	Y=254	Y=279	Y=305
	730	756	781	806	832	857	883	908	933	959	984	1010	1035

**NOTE:**

Internal chassis and air openings remain the same. External cabinet can increase in height and width in 1" (25.4mm) increments up to 12" (305mm).

# DIMENSIONAL DATA: FW SERIES

## MODEL FWX PARAMETRIC INCREMENTS

[View drawing online](#)

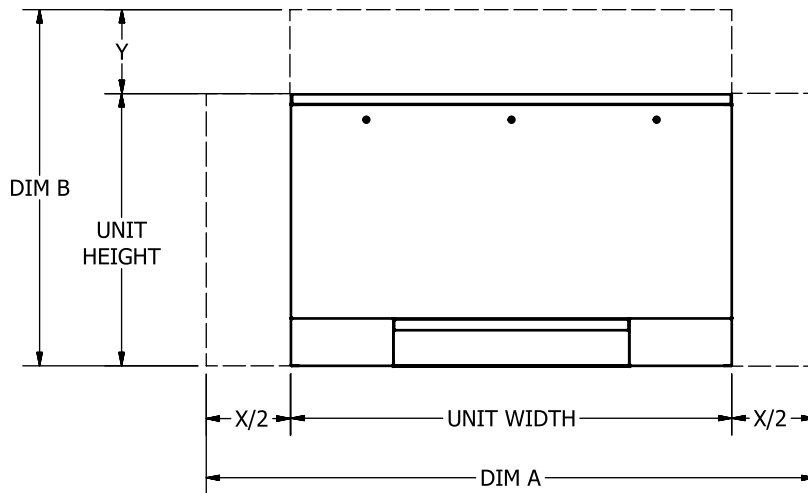

DIMENSION A (inches)													
SIZE	X=0	X=1	X=2	X=3	X=4	X=5	X=6	X=7	X=8	X=9	X=10	X=11	X=12
02	41	42	43	44	45	46	47	48	49	50	51	52	53
03	45	46	47	48	49	50	51	52	53	54	55	56	57
04	51	52	53	54	55	56	57	58	59	60	61	62	63
06	61	62	63	64	65	66	67	68	69	70	71	72	73
08	63	64	65	66	67	68	69	70	71	72	73	74	75
10	77	78	79	80	81	82	83	84	85	86	87	88	89
12	85	86	87	88	89	90	91	92	93	94	95	N/A	N/A
DIMENSION B (inches)													
ALL SIZES	Y=0	Y=1	Y=2	Y=3	Y=4	Y=5	Y=6	Y=7	Y=8	Y=9	Y=10	Y=11	Y=12
	25 1/4	26 1/4	27 1/4	28 1/4	29 1/4	30 1/4	31 1/4	32 1/4	33 1/4	34 1/4	35 1/4	36 1/4	37 1/4

DIMENSION A (millimeters)													
SIZE	X=0	X=25	X=51	X=76	X=102	X=127	X=152	X=178	X=203	X=229	X=254	X=279	X=305
02	1041	1067	1092	1118	1143	1168	1194	1219	1245	1270	1295	1321	1346
03	1143	1168	1194	1219	1245	1270	1295	1321	1346	1372	1397	1422	1448
04	1295	1321	1346	1372	1397	1422	1448	1473	1499	1524	1549	1575	1600
06	1549	1575	1600	1626	1651	1676	1702	1727	1753	1778	1803	1829	1854
08	1600	1626	1651	1676	1702	1727	1753	1778	1803	1829	1854	1880	1905
10	1956	1981	2007	2032	2057	2083	2108	2134	2159	2184	2210	2235	2261
12	2159	2184	2210	2235	2261	2286	2311	2337	2362	2388	2413	N/A	N/A
DIMENSION B (millimeters)													
ALL SIZES	Y=0	Y=25	Y=51	Y=76	Y=102	Y=127	Y=152	Y=178	Y=203	Y=229	Y=254	Y=279	Y=305
	641	667	692	718	743	768	794	819	845	870	895	921	946

**NOTE:**

Internal chassis and air openings remain the same. External cabinet can increase in height and width in 1" (25.4mm) increments up to 12" (305mm).

# DIMENSIONAL DATA: FW SERIES

## OUTSIDE AIR DAMPER

[View drawing online](#)

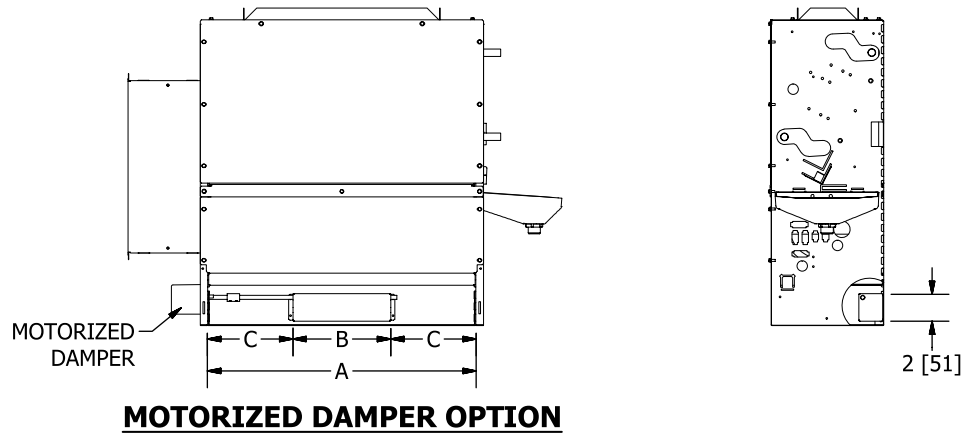
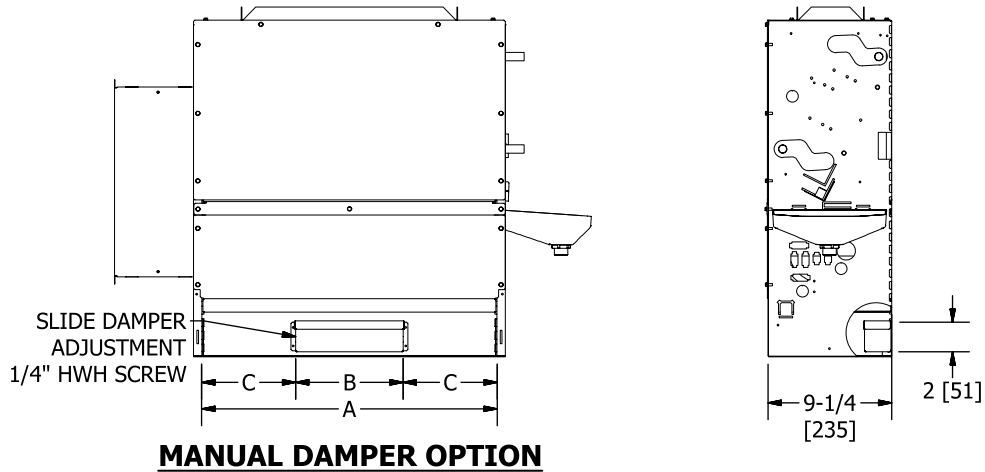

DIMENSIONS - In [mm]			
UNIT SIZE	A	B	C
02	22 [559]	8 [203]	7 [178]
03	26 [660]	10 [254]	8 [203]
04	32 [813]	12 [305]	10 [254]
06	42 [1067]	14 [356]	14 [356]
08	44 [1118]	18 [457]	13 [330]
10	58 [1473]	27 [686]	15 1/2 [394]
12	66 [1676]	27 [686]	19 1/2 [495]

**NOTES:**

1. All dimensions are inches [millimeters]. All dimensions are ± 1/4" [6mm]. Metric values are soft conversion.
2. Model FWC shown; typical for Models FWX and FWI.
3. The standard damper options may not provide freeze protection under all conditions and applications. Other forms of freeze protection may be required.
4. Right hand unit shown; left hand unit is similar but opposite.

# DIMENSIONAL DATA: FW SERIES

## WALL BOX

[View drawing online](#)

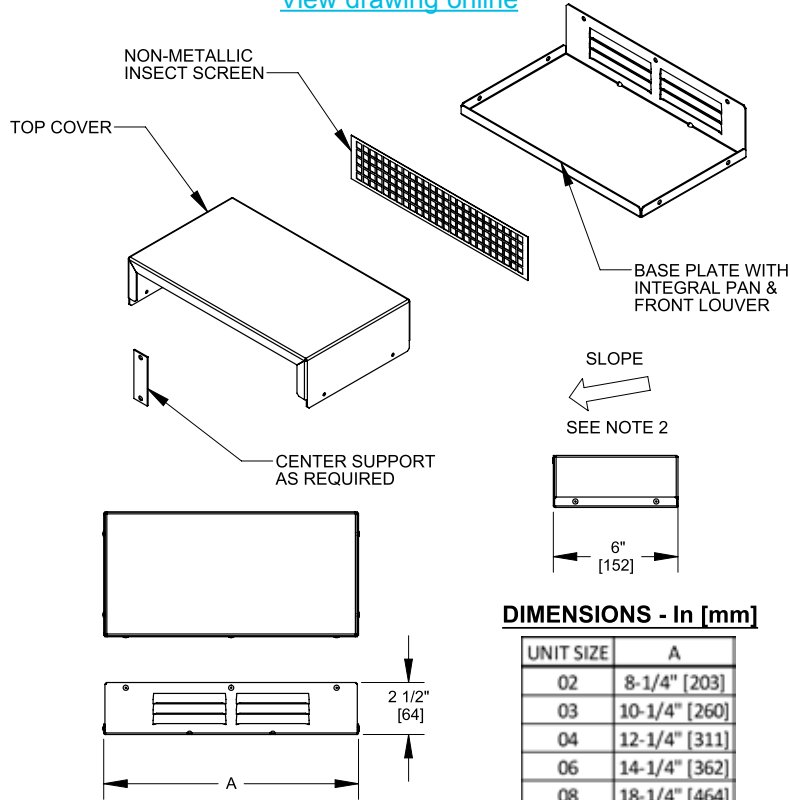

### DIMENSIONS - In [mm]

UNIT SIZE	A
02	8-1/4" [203]
03	10-1/4" [260]
04	12-1/4" [311]
06	14-1/4" [362]
08	18-1/4" [464]
10	27-1/4" [692]
12	27-1/4" [692]

**NOTES:**

1. Material is .050" aluminum.
2. Wall box should be installed pitched slightly toward exterior surface of wall.
3. "Weep" holes should not be obstructed when sealing box to the wall.

## RETURN AIR TOE KICK

[View drawing online](#)

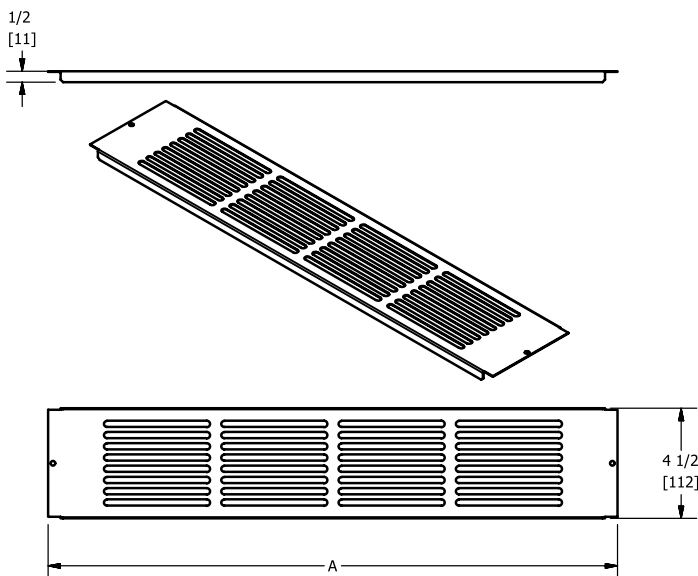

PART NUMBER	UNIT SIZE	DIM A
51-00437-01	02	22 3/4 [578]
51-00437-02	03	26 3/4 [679]
51-00437-03	04	32 3/4 [832]
51-00437-04	06	42 3/4 [1086]
51-00437-05	08	44 3/4 [1137]
51-00437-06	10	58 3/4 [1492]
51-00437-07	12	66 3/4 [1695]

**NOTES:**

1. All dimensions are inches [millimeters]. All dimensions are ± 1/4" [6mm]. Metric values are soft conversion.
2. Typical for FWX or FWI models.
3. Return grille is held in place with sheet metal screws.



# DIMENSIONAL DATA: FL SERIES

## MODEL FLC CONCEALED

[View drawing online](#)

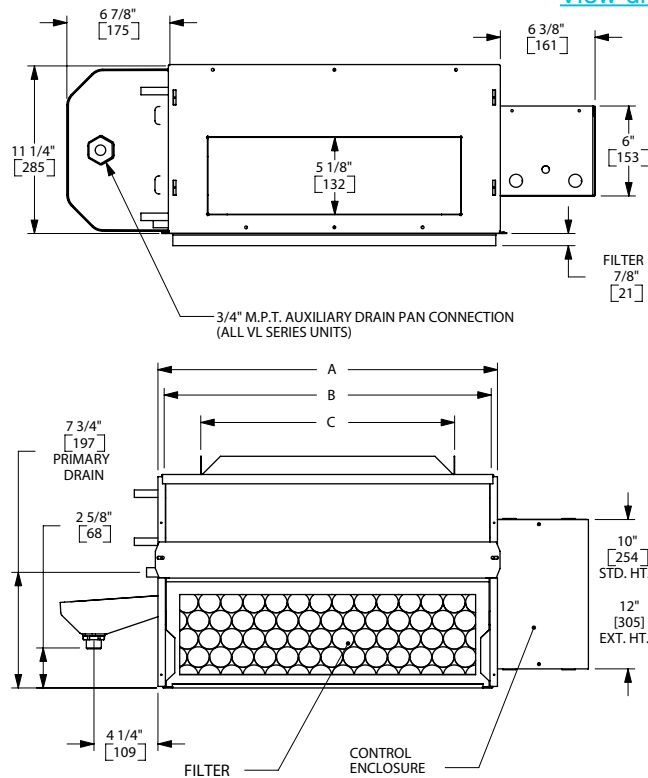

UNIT SIZE	DIMENSION		
	A	B	C
02	23" [584]	22" [559]	17" [432]
03	28" [711]	27" [686]	22" [559]
04	36" [914]	35" [889]	30" [762]
06	50" [1270]	49" [1245]	44" [1118]

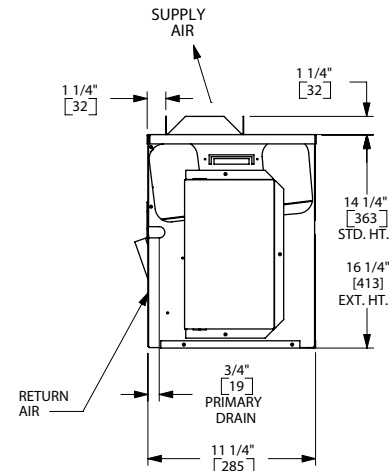

**NOTES:**

1. All dimensions are inches [mm] and are ± 1/4" [6mm]. Metric values are soft conversion.
2. Junction box size and location varies with unit features. Control options may be limited. Provide sufficient clearance to access electrical controls and comply with applicable codes and ordinances.
3. Left hand unit shown; right hand unit similar but opposite.
4. Auxiliary drain pan ships loose for field installation.

## MODEL FLX EXPOSED CABINET

[View drawing online](#)

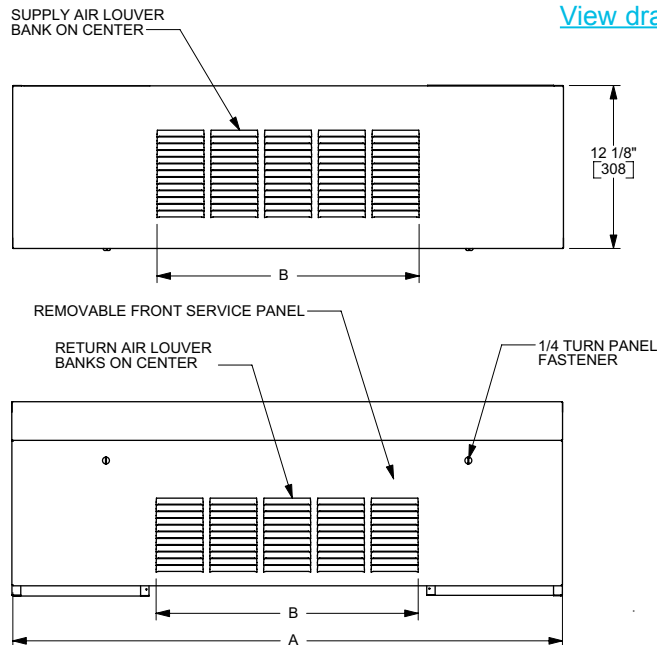

UNIT SIZE	DIMENSION	
	A	B
02	41" [1041]	19 1/2" [495]
03	46" [1168]	23 1/2" [597]
04	54" [1372]	31 1/2" [800]
06	68" [1727]	43 1/2" [1105]

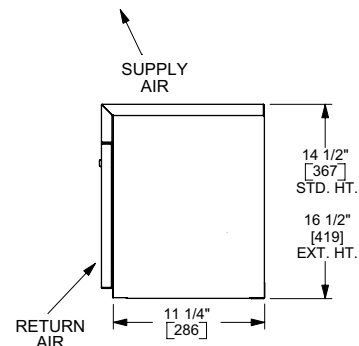

**NOTES:**

1. See notes 1, 2 and 3 above.
2. Standard cabinet finish is Pearl White Satin.

# PIPING PACKAGES

All the packages and components described in this brochure are optional, extra cost features. Consult your Johnson Controls sales representative for details. Not all components are available on all unit models. See valve package code charts.

All standard valve packages and piping components described in this catalog are for chilled and hot water applications. They may also be used with ethylene and propylene glycol solutions up to 50% concentration.

FW and FL fan coil unit packages are factory assembled and shipped loose for field installation and wiring.

FW and FL unit valve packages are designed to mount directly onto the coil connections.

Control valve actuators are removable, and may be serviced or replaced without removal of the valve body.

Control valves are piped normally closed to the coil. Control valves are available normally open.

3-Way control valves are piped as mixing valves.

All ball isolation valves are furnished with an adjustable memory stop feature and may be used as a balancing valve.

Optional unions are installed at the water coil, and are available on VAV products, and all fan coil units except VH. Unions must be ordered on both coils of 4-pipe units. Unions are not available separately.

Pressure/temperature (P/T) ports are located to monitor the pressure and temperature across the coil.

Automatic fixed flow controls (FC, FCN, FCS) are available in flow (GPM) ratings as follows:

1/2"	Flow Rating	Increment
	0.5 - 4.0 GPM	0.5 GPM
>4.0 - 6.0 GPM	1.0 GPM	

Individual coil GPM requirements must be specified at time of order. FC = 2-8 psig AFS.



Valve and component performance ratings shown are maximum values. Appearance and actual ratings may vary with component size.

Adjustable flow setter (AFS) is rated for full shut-off and replaces the return line ball isolation valve on all products except the VH fan coil unit.

2-Pipe "change-over" units using a 2-way control valve and factory thermostat must be ordered with a 1/4" "bleed" line to assure proper changeover thermostat (aquastat) operation. The 1/4" "bleed" line is optional on 2-pipe "changeover" units with field provided thermostats.

Some piping packages may require extended end pocket with extended auxiliary drain pan. Requirements for field furnished and installed valve package and piping insulation must be determined by others on an individual application basis.

Actuators supplied with factory mounted piping packages include color coded plug and play connections with insulated wire to connect to relay board.

The valve package piping and component details shown in this catalog are for standard valves and components. The suitability of all valve packages and components must be determined by others based on individual application requirements. Johnson Controls assumes no responsibility for selection and/or application of valve packages and components.

Modulating cooling valve control can increase part load space relative humidity. Johnson Controls does not encourage or endorse modulating valve control for fan coil cooling systems, and is not liable for high humidity problems that may result. Modulating heating valve control may result in low leaving air temperatures while the valve reduces flow and as setpoint is approached.

Contact the factory for any requirements not shown in this catalog.

## CONTROL DEVICE LEGEND

MANUAL BALL VALVE WITH MEMORY STOP (BVALS)		2-WAY CONTROL VALVE		3-WAY CONTROL VALVE	
FIXED FLOW CONTROL VALVE (FC)		AUTOMATIC CARTRIDGE FLOW CONTROL WITHOUT SCREEN		AUTOMATIC CARTRIDGE FLOW CONTROL WITH SCREEN	
ADJUSTABLE FLOW CIRCUIT SETTER (AFS)		BYPASS BALANCE VALVE (BPV)		PRESSURE-TEMPERATURE TEST PORT (PT)	
Y-STRAINER (Y-STR)		Y-STRAINER W/CLEANOUT VALVE (YCO)		UNION	
FLEXIBLE HOSE (FH)		AQUA-THERMOSTAT		SCHRADER FITTING	

# PIPING PACKAGES

2-WAY PIPING PACKAGE												
Package Code	Components			Valve Size			Unions			P/T Ports	1/4" Bleed Line	Y-STR w/ BDV
	BVMS	FC	AFS	1/2"	3/4"	1"	1/2"	3/4"	1"			
24	X									X	X	X
25	X	X		X	X	X	X	X	X	X	X	X
29	X		X							X	X	X

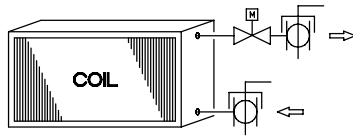

**Code 24**  
2-Way Control Valve and Ball Valves With Memory Stop

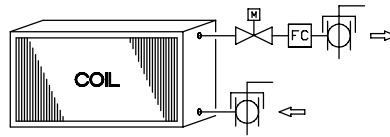

**Code 25**  
2-Way Control Valve, Ball Valves with Memory Stop, and Fixed Flow Control

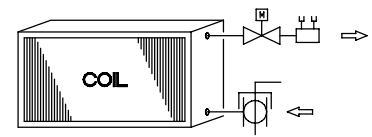

**Code 29**  
2-Way Control Valve, Ball Valve with Memory Stop, and Adjustable Flow Setter

3-WAY PIPING PACKAGE												
Package Code	Components			Valve Size			Unions			P/T Ports	Y-STR w/ BDV	
	BVMS	FC	AFS	1/2"	3/4"	1"	1/2"	3/4"	1"			
36	X									X	X	
37	X	X		X	X	X	X	X	X	X	X	
41	X		X							X	X	

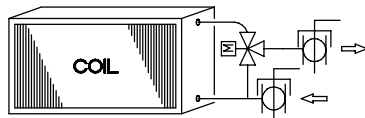

**Code 36**  
3-Way Control Valve and Ball Valves With Memory Stop

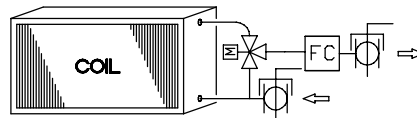

**Code 37**  
3-Way Control Valve, Ball Valves with Memory Stop, and Fixed Flow Control

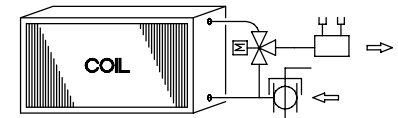

**Code 41**  
3-Way Control Valve, Ball Valve With Memory Stop, and Adjustable Flow Setter

3-WAY PACKAGE WITH BALANCE BYPASS VALVE												
Package Code	Components			Valve Size			Unions			P/T Ports		
	BVMS	FC	AFS	1/2"	3/4"	1"	1/2"	3/4"	1"			
50	X			X	X	X	X	X	X	X		
53	X		X	X	X	X	X	X	X	X		

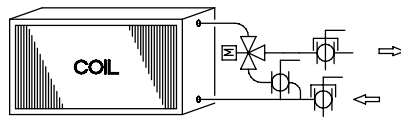

**Code 50**  
3-Way Control Valve, Ball Valve in Bypass, and Ball Valves With Memory Stop

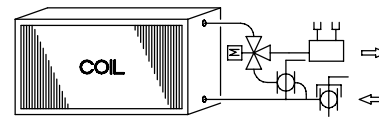

**Code 53**  
3-Way Control Valve, Ball Valve in Bypass, Ball Valve With Memory Stop, and Adjustable Flow Setter

### LEGEND, COMPONENT PRESSURE RATINGS

- BVMS: Manual Ball Valves w/Memory Stop, 600 PSIG
- FC: Fixed Flow Control, 500 PSIG
- AFS: Adjustable Flow Circuit Setter, 300 PSIG
- P/T Port: Pressure/Temperature Test Port, 400 PSIG
- Union: 125 PSIG (contact factory for 600 PSIG)
- Control Valve: 300 PSIG
- BPV: Balance Bypass Valve, 400 PSIG
- Y-STR: Y-Strainer
- BDV: Blow Down Valve

### NOTES:

1. All drawings subject to change without prior notice.
2. Diagrams show component position in relation to fluid flow. Actual valve package configuration varies with unit type, hand connection, and pipe size.
3. 1/4" bleed line is required on 2-pipe cool and heat auto changeover systems with factory provided thermostats; optional for thermostats by others.
4. Unions provided as standard on all FW piping packages.

# PIPING PACKAGES

## Piping System Component Maximum Working Pressure (PSIG)

System Working Pressure (PSIG)	Water and Steam Coil		Ball Valves	Motorized Control Valves <sup>1</sup>		Flow Control			1/4" Schrader Valve	Pressure / Temp. Test Port	Flexible Hose Kit	Y-Strainer		Unions <sup>4</sup>
	Coil	Air Vent		2 Position	Modulating <sup>2</sup>	Automatic	Adjustable	Body				Clean-out		
100	250 @ 200°F, 15 PSIG Steam	Manual: 400 @ 200°F	600 @ 200°F	1/2" (40)	1/2" (50)	Fixed: 500 @ 225°F	Cartridge <sup>3</sup> : 230 @ 250°F	Circuit Setter: 300 @ 400°F	Balance Valve: 400 @ 200°F	400 @ 250°F	375 @ 250°F	400 @ 150°F	400 @ 200°F	500 @ 200°F
200														
300														
400														
500														
600														

- Notes:**
- All valves use sweat connections. 2 position valves are N.C. spring return; modulating valves are floating point non-spring return fail in place.
  - Valve close off pressure is rated at powered operating mode.
  - Cartridge type flow control devices utilize a replaceable flow compensation cartridge to adjust desired flow rate.
  - Contact factory for unions rated at 600 PSIG and 325°F.
  - Pressure ratings will be reduced as temperatures exceed those shown above.
  - Maximum allowable system pressure is limited to the components selected with the lowest working pressure.
  - Johnson Controls assumes no responsibility for misapplication and selection of piping components.

(xx) = Valve close off pressure

## PIPING PACKAGES



### Manual Ball Valve w/Memory Stop (BVMS)

An adjustable stop position lever to limit travel of the On/Off handle. This allows the ball valve to be closed, and returned to the balance setting position without re-testing the system. 1/2" size shown.

Nominal Size:	1/2"	3/4"	1"
Body Material:	Brass	Brass	Brass
Ball:	Hard Chrome Plated	Hard Chrome Plated	Hard Chrome Plated
Seats:	Teflon	Teflon	Teflon
Stem Seal:	(2) Viton O-Rings	Teflon	Teflon
Connection:	Sweat	Sweat	Sweat
Pressure Rating (psig):	600	600	600
Temp. Rating, °F:	325	325	325
Cv:	17	32	27



### Flexible Hose Kits, 18" (FH)

Materials:	EPDM inner lined, KeFLar® reinforced hose with stainless steel outer covering
Flow Rates:	0.5 to 12.0 GPM, based on application
Pressure Temp. Rating (450 PSIG test pressure)	375 PSIG @ 250°F
Minimum Burst Pressure:	1500 PSI
Flame Spread:	Not greater than 25 per UL 723
Smoke Development:	Not greater than 50 per UL 723
Ball Valve w/Memory Stop:	Full port brass
Ball:	Stainless steel
Seats:	Teflon
Stem Seal:	(2) Viton O-Rings
Pressure Rating:	600 PSIG WOG
Temperature Rating:	325°F
Cv:	20

Available in 1/2" size only.



### Typical 2-Way, 2-Position Control Valve

A 2-position water control valve driven open with spring return upon a call for heating or cooling to maintain space temperature. In open position, water can flow through the unit's water coil to heat or cool the space depending on supply water temperature. In closed position, water cannot flow through the water coil. Control valves are piped normally closed to the coil as standard. Valve actuators can be line or low (24VAC) voltage.

Nominal Size	1/2" 2-Way	3/4" 2-Way	1" 2-Way
Body Material:	Brass	Brass	Brass
Connection:	Sweat	Sweat	Sweat
Pressure Rating (psig):	300	300	300
Temperature Rating, °F:	200	200	200
Cv:	2.5	5.0	8.0
Maximum Close-off Pressure, Std. (PSIG):	40	20	17
High Close-off:	50	25	20
Power Consumption:	7VA	7VA	7VA

## PIPING PACKAGES



### Typical 3-Way, 2-Position Control Valve

A 2-position water control valve driven open with spring return (bypass) upon a call for heating or cooling to maintain space temperature. Energized, the bypass port is blocked, and water can flow through the unit's water coil to heat or cool the space depending on the supply water temperature. De-energized, water cannot flow through the water coil but is forced to flow through the bypass port, bypassing the coil. Control valves are piped normally closed to the coil as standard (in full bypass). Valve actuators can be line or low (24VAC) voltage.

Nominal Size	1/2" 3-Way	3/4" 3-Way	1" 3-Way
Body Material:	Brass	Brass	Brass
Connection:	Sweat	Sweat	Sweat
Pressure Rating (psig):	300	300	300
Temperature Rating, °F:	200	200	200
Cv:	3.0	5.0	8.0
Maximum Close-off Pressure (PSIG):	N/A	N/A	N/A
Power Consumption:	7VA	7VA	7VA



### Typical 2-Way Modulating Control Valve

A 3-wire floating point, fail-in-place (non-spring return) modulating water control valve, driven open or closed upon a call for heating or cooling to maintain space temperature. In the open position, water can flow through the unit's water coil to heat or cool the space depending on supply water temperature. In the closed position, water cannot flow through the water coil. Factory furnished 2-way valve packages are piped normally closed to the water coil. The floating point control valve is compatible with any 24VAC three-wire signal when three minute time-out logic resides in the thermostat or system controller.

Nominal Size	1/2" 2-Way	3/4" 2-Way	1" 2-Way
Body Material:	Brass	Brass	Brass
Connection:	Sweat	Sweat	Sweat
Pressure Rating (psig):	300	300	300
Temperature Rating, °F:	200	200	200
Cv:	2.0	4.0	8.0
Maximum Close-off Pressure			
Operating Mode:	50	35	35
Power Consumption:	1VA	1VA	1VA

Contact factory for 3-wire floating, spring return applications.



### Typical 3-Way Modulating Control Valve

A 3-wire floating point, fail-in-place (non-spring return) modulating water control valve, driven open or closed (bypass) upon a call for heating or cooling to maintain space temperature. In the "open" position, the bypass port is closed and water is directed through the unit's water coil to heat or cool the space depending on supply water temperature. In the "closed" position, the service (water coil) port is closed and water is directed through the bypass port. Factory furnished 3-way valve packages are piped as "mixing" valves. The floating point control valve is compatible with any 24VAC three-wire signal when three minute time-out logic resides in the thermostat or system controller.

Nominal Size	1/2" 3-Way	3/4" 3-Way	1" 3-Way
Body Material:	Brass	Brass	Brass
Connection:	Sweat	Sweat	Sweat
Pressure Rating (psig):	300	300	300
Temperature Rating, °F:	200	200	200
Cv:	2.0	4.0	8.0
Maximum Close-off Pressure			
Operating Mode:	N/A	N/A	N/A
Power Consumption:	1VA	1VA	1VA

Contact factory for 3-wire floating, spring return applications.

## PIPING PACKAGES



### Automatic Fixed Flow Control (FC)

A pressure compensated automatic fixed flow control device designed to limit the flow GPM through the unit coil. Desired GPM must be specified when ordering. Device A shown is typical for controlling flow up to 8.0 GPM, and features a changeable flow cartridge. Device B is typical for flows above 8.0 GPM.

Nominal Size (A):	1/2" and 3/4"
Nominal Size (B):	3/4" and 1"
Body Material:	Copper
Connection:	Sweat
Pressure Rating (psig) (A):	600
Pressure Rating (psig) (B):	522
Temp. Rating, °F:	220
Cv:	Variable With Inlet Pressure



### Automatic Cartridge Flow Control (FCN, FCS)

An automatic fixed flow control device with a replaceable stainless steel cartridge, and two pressure/temperature ports, designed to limit the flow GPM through the unit coil to  $\pm 5\%$  of rated GPM. Desired GPM must be specified when ordering. Available with 20 mesh stainless steel screen. 1/2" size shown.

Nominal Size:	1/2", 3/4", and 1"
Body Material:	Forged brass
Connection:	Sweat
Seals:	EPDM O-Rings
Pressure Rating (psig):	230
Temp. Rating, °F:	250
PSIG Range:	2 - 32

#### Optional Strainer:

Body Material:	20 mesh stainless steel*
----------------	--------------------------

\* The optional strainer is internal and does not affect the dimensions.



### Adjustable Flow Circuit Setter (AFS)

A control device designed to allow maximum water flow through the unit coil in the Open (0%) position, and as little as 10% of flow through the unit coil in the Closed (90%) position. The device has a calibrated nameplate, built in test ports and adjustable mechanical stops, and is suitable for positive shutoff.

Nominal Size:	1/2", 3/4", and 1"
Body Material:	Bronze
Connection:	Sweat
Pressure Rating (psig):	300
Temp. Rating, °F:	250
Cv:	Variable

## PIPING PACKAGES



### Balance Bypass Valve (BPV)

A plug type valve designed to balance the water flow through the bypass circuit of a 3-way control valve. Manual adjustment is required. No calibration is provided at the valve.

Nominal Size:	1/2", 3/4", and 1"
Body Material:	Bronze
Connection:	Sweat
Pressure Rating (psig):	400
Temp. Rating, °F:	200
Cv:	Adjustable



### Unions

A fitting used to provide a mechanical connection between the coil and valve package that can be connected, disconnected, and re-connected without the need to cut tubing or unsolder a joint. Unions are installed at the coil on HL, HP, and FW fan coil units. Unions are not available on VH fan coil units.

Nominal Size:	1/2", 3/4", and 1"
Body Material:	Bronze/Copper
Connection:	Sweat
Pressure Rating (psig):	500
Temp. Rating, °F:	200

\*Contact factory for unions rated at 600 PSIG and 325°F.



### Y-Strainer (Y-STR)

Designed to allow water to flow through a built in screen to filter debris or contaminants from the water system. With the water system isolated, the plug can be removed from the blowdown leg of the strainer and the captured debris removed from the screen. After the plug is replaced, the system can be put back in operation and the strainer will continue to filter the unit's water.

Nominal Size:	1/2" and 3/4"
Body Material:	Forged Brass
Connection:	Sweat
Pressure Rating (psig):	600
Temp. Rating, °F:	325
Screen:	20 Mesh Stainless Steel



## PIPING PACKAGES



### Blow Down Valve (BDV)

A standard ball valve installed on the strainer blowdown leg to allow flushing the strainer screen without removing the plug in the blowdown leg. This valve has a standard 1/2" garden hose connection to allow fluid to be piped to a container or remote location during cleaning. Not available separately.

Nominal Size:	1/4"
Body Material:	Bronze
Connection:	MPT
Pressure Rating (psig):	600
Temp. Rating, °F:	200



### Optional Pressure/Temperature

#### Test Port Locations (P/T)

Designed to allow testing of water pressure, differential pressure or water temperature without interrupting the waterside operation of the Fan Coil Unit. Sensor probes (1/8") are not included.

Nominal Size:	1/4"
Body Material:	Brass
Connection:	MPT
Pressure Rating (psig):	400
Temp. Rating, °F:	250



### Aqua Thermostat

The aqua thermostat, also called an automatic seasonal changeover switch or aquastat, is a switch designed to change a room thermostat from heating to cooling and back, based on the temperature of the water supplied to a 2-pipe unit to be used for both heating and cooling. The switch is shipped loose and is mounted in the field on the water tubing using the integral clip or spring.

Nominal Size:	1/2", 3/4" and 1"
Switch Action:	SPDT Switch on temperature rise, 85°F (± 6°F) Switch on temperature fall, 70°F (± 6°F)
Current Rating:	120VAC = 5.8 FLA/34.8 LRA (Inductive), 10.0 Amps (Resistive) 208/240VAC = 2.9 FLA/17.4 LRA (Inductive), 2.0 Amps (Resistive) 277VAC = 3.6 FLA/21.6 LRA (Inductive), 1.0 Amp (Resistive)

Agency Approval: UL Listed, CSA Approved  
Ratings may vary with vendor and size.

## GUIDE SPECIFICATIONS: FW AND FL SERIES

### GENERAL

Furnish and install Johnson Controls Vertical Floor Direct Drive Fan Coil Units where indicated on the plans and in the specifications. All units shall be capable of meeting or exceeding the scheduled capacities for cooling, heating and air delivery. Units shall be ETL listed in compliance with UL/ANSI Standard 1995, and be certified as complying with ARI Standard 440-2008.

### CONSTRUCTION

All unit chassis shall be fabricated of heavy gauge galvanized steel panels able to meet 125 hour salt spray test per ASTM B-117. All unit chassis panels shall be insulated with Elastomeric Closed Cell Foam Insulation. Insulation shall conform to UL 181 for erosion and NFPA 90A for fire, smoke and melting, and comply with a 25/50 Flame Spread and Smoke Developed Index per ASTM E-84 or UL 723. Additionally, insulation shall comply with Antimicrobial Performance Rating of 0, no observed growth, per ASTM G-21. Polyethylene or Fiberglass insulation is not acceptable.

All exposed units shall have exterior panels fabricated of not less than 20 gauge galvanized steel [Provide a 16 gauge front panel on exposed units]. The front panel shall be attached with quarter turn quick open fasteners to allow for easy removal and access for service. [The front panel shall be attached with tamper proof fasteners. Side panels shall be removable for access to controls and piping within the end pockets].

Top panel shall be removable from fan coil without the need to disconnect piping or electrical wiring (FWX/FWI). The top panel shall be removed through not more than 8 screws.

Provide a grille in the return air opening (FLX only). [Provide a grille in the return air opening. (FWX, FWI).] [Provide a decorative return air opening (FWC).]

All exposed units shall include a recessed stamped louver discharge grille. Louver discharge grille shall be reverse stamped (FWI only). [Provide an architectural grade linear bar discharge grille with a powder coated paint finish to match cabinet color. Liquid coat paint shall not be acceptable.]

All concealed units shall have a minimum 1" duct collar on the discharge.

### PAINTED FINISH

All painted cabinet exterior panels shall be finished with a heat cured anodic acrylic powder paint of the standard factory color. Liquid coat paint shall not be acceptable.

### SOUND

Units shall have published sound power level data tested in accordance with ARI Standard 350.

### POWER

Units shall not exceed scheduled power consumption.

### FAN & MOTOR

Unit fan shall be dynamically balanced, forward curved, DWDI centrifugal type constructed of galvanized steel for corrosion resistance. Motors shall be high efficiency, permanently lubricated sleeve bearing, permanent split-capacitor type with UL and CSA listed automatic reset thermal overload protection and three separate horsepower taps. Shaded pole motors are not acceptable. Single speed motors are not acceptable.

The fan/motor assembly shall be removable and serviceable through the front panel. Each fan/motor assembly shall be fastened by no more than 2 screws. The fan/motor assembly shall be no longer than 44", and shall be easily removable by a single service technician. The motors shall have quick connectors to allow service and removal without the need for tools.

### DRAIN PAN

Primary condensate drain pans shall be single wall, heavy gauge galvanized steel for corrosion resistance, and extend under the entire coil section. Drain pans shall be of one piece construction and be positively sloped for condensate removal. Drain pan access that requires removal of coils is not acceptable.

The primary drain pan shall be externally insulated with a fire retardant, elastomeric closed cell foam insulation. The insulation shall carry no more than a 25/50 Flame Spread and Smoke Developed Rating per ASTM E-84 and UL 723 and an Antimicrobial Performance Rating of 0, no observed growth, per ASTM G-21. Double wall non-corrosive auxiliary drain pan is used for condensate from primary drain pan and optional valve packages.

**Option:** Provide a primary drain pan constructed entirely of heavy gauge stainless steel for superior corrosion resistance.

### COILS

All cooling and heating coils shall optimize rows to meet the specified capacity. Coils shall have seamless copper tubes and shall be mechanically expanded to provide an efficient, permanent bond between the tube and fin. Minimum copper tube thickness shall be .016" [.025"].

Fins shall have high efficiency aluminum [copper] surface optimized for heat transfer, air pressure drop and carryover. Lanced fins shall not be acceptable.

## GUIDE SPECIFICATIONS: FW AND FL SERIES

All coils shall be tested at 325 PSIG air pressure under water, and rated for a maximum 300 PSIG working pressure at 200°F. Coils shall be circuited for counter flow to maximize unit efficiency.

All water coils shall be designed to connect with ½" nominal pipe connections.

Coil Casing shall be fabricated from galvanized steel [stainless steel].

Heating coils shall be furnished in the pre-heat (FW Only) or re-heat position.

Direct expansion cooling coils shall be factory sealed and charged with minimum 25 PSIG nitrogen or refrigerated dry air.

Steam coils shall be standard single tube steam type suitable for temperatures above 35°F and 15 PSIG steam pressure.

All water coils shall be provided with a manual air vent fitting to allow for coil venting.

### FILTERS

All units shall be furnished with a minimum 1" nominal glass fiber throwaway (1" pleated MERV 7) (1" pleated MERV 8) (1" pleated MERV 13) filter. Filters shall be tight fitting to prevent air bypass. Filters shall be easily removable from the return air opening without the need for tools (FW Only).

### ELECTRICAL

Units shall be furnished with single point power connection. Provide an electrical junction box for motor and other electrical terminations.

**Option:** Provide 24 VAC fan relay board with 25 VA transformer. Fan relay board designed to operate in conjunction with factory provided (field provided) 24 V thermostat. Fan relay board designed to accept 115, 208, 220, 230, or 277 V input power. Fan relay board to be factory installed.

Relay board shall operate with generic thermostat designed to control up to three independently energized fan speeds.

### ELECTRIC HEAT

Furnish an electric resistance heating assembly as an integral part of the fan coil unit, with the heating capacity, voltage and kilowatts scheduled. The heater assembly shall be rated for installation on the fan coil unit and be located so as not to expose the fan assem-

bly to excessive leaving air temperatures that could affect motor performance.

The heater and unit assembly shall be listed for zero clearance and meet all NEC requirements, and be ETL listed with the unit as an assembly in compliance with UL/ANSI Standard 1995.

All heating elements on floor mounted units shall be finned tubular type. Elements shall be constructed of nickel chromium resistance wire centered in tubes and embedded in refractory material. Terminals shall be sealed with silicone rubber to protect against moisture. Terminals and hardware shall be stainless steel for corrosion resistance. All internal wiring shall be rated for 105°C minimum.

All heaters shall include over temperature protection consisting of an automatic reset primary thermal limit and back-up secondary thermal limit. All heaters shall be single stage.

**Option:** Devices used to energize and de-energize (switch) electric heat must be totally silent. Magnetic, mercury, and/or quiet relays and/or contactors are not acceptable.

### PIPING PACKAGES

Provide a standard factory assembled valve piping package to consist of a 2 or 3-way, on/off, motorized electric control valve and two ball isolation valves.

Control valves shall be piped normally closed to the coil. Control valves shall be wired to relay board through quick connects to allow service and replacement of valves. Quick connects shall prevent incorrect wiring through physical and color coded visual confirmation. Maximum entering water temperature on the control valve shall be 200°F, and maximum operating pressure shall be 300 PSIG.

Unions shall be provided to allow removal of piping package from unit without the need for brazing or cutting pipe.

**Option:** Provide 3-wire floating point modulating control valve (fail-in-place), in lieu of standard 2-position control valve with factory assembled valve piping package.

**Option:** Provide high pressure close-off actuator for 2-way on/off control valve. Maximum close-off pressure is 50 PSIG (1/2"), 25 PSIG (3/4"), or 20 PSIG (1").

**Option:** Provide either a fixed or adjustable flow control device for each piping package.

## **GUIDE SPECIFICATIONS: FW AND FL SERIES**

---

**Option:** Provide pressure-temperature ports (P/T) for each piping package to allow measurement across the coil.

Piping packages shall be completely factory assembled, including interconnecting pipe and shipped loose for field installation.

**Option:** Piping package will be shipped factory installed.

### **OUTSIDE AIR DAMPER (FW Only)**

Provide a manual or two position motorized outside air damper integral to the unit.

**Option:** Provide aluminum outside air wall box (FW Only) with integral insect screen and weep holes for field installation.

Printed on recycled paper

Form 115.26-EG9 (710) Supersedes: Form 115.26-EG9 (510)  
© 2010 Johnson Controls, Inc. P.O. Box 423, Milwaukee, WI 53201 Printed in USA  
[www.johnsoncontrols.com](http://www.johnsoncontrols.com)

