



Heating and Air Conditioning

TECHNICAL GUIDE

R-410A

AFFINITY™ SERIES

DNX, DNQ, DNZ MODELS

2 - 5 TON

60 Hertz

Description

These York® Affinity™ packaged cooling/heating air conditioners are designed for outdoor installation. Only utility and duct connections are required at the point of installation.

The single or two stage gas-fired heaters have aluminized steel tubular heat exchangers and spark to pilot ignition. They are available in natural gas with field conversion to propane.

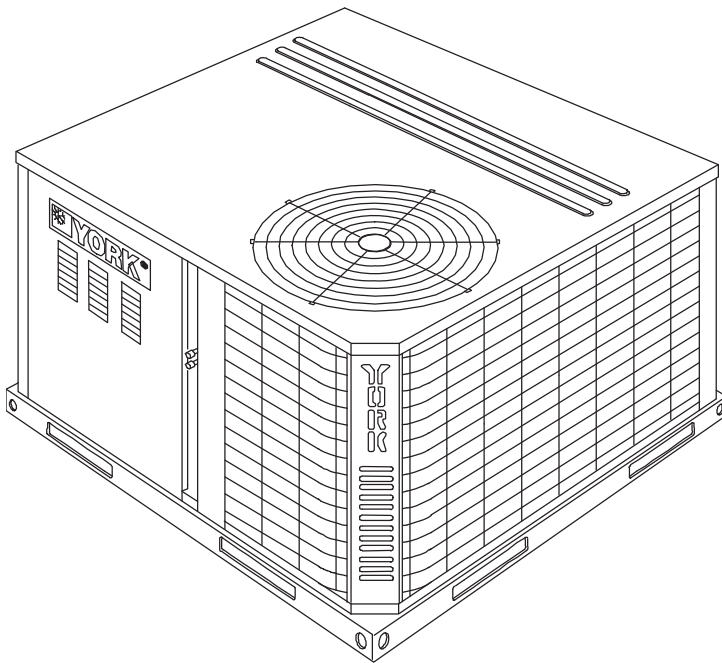

Tested in accordance with:



ISO 9001
Certified Quality
Management System

Table of Contents

Description	1
Table of Contents	2
Component Location	2
Nomenclature	3
Features and Benefits	3
Guide Specifications	5
Physical Data	7
Capacity Performance	14
Airflow Performance	42
Sound Performance	54
Electrical Data	55
Typical DNX/DNQ/DNZ024-060 Wiring Diagrams	57
Weights and Dimensions	83

Component Location

Cooling/Gas Unit

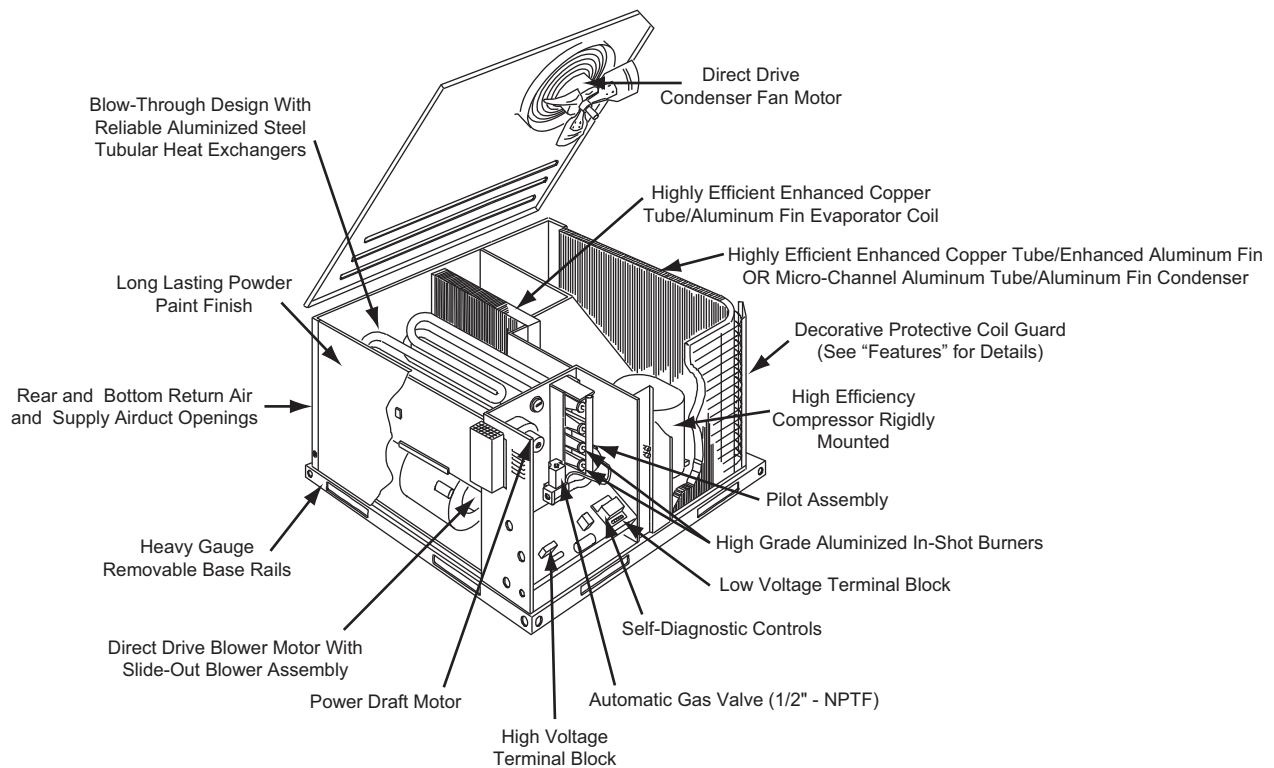

Nomenclature

Cooling/Gas Unit

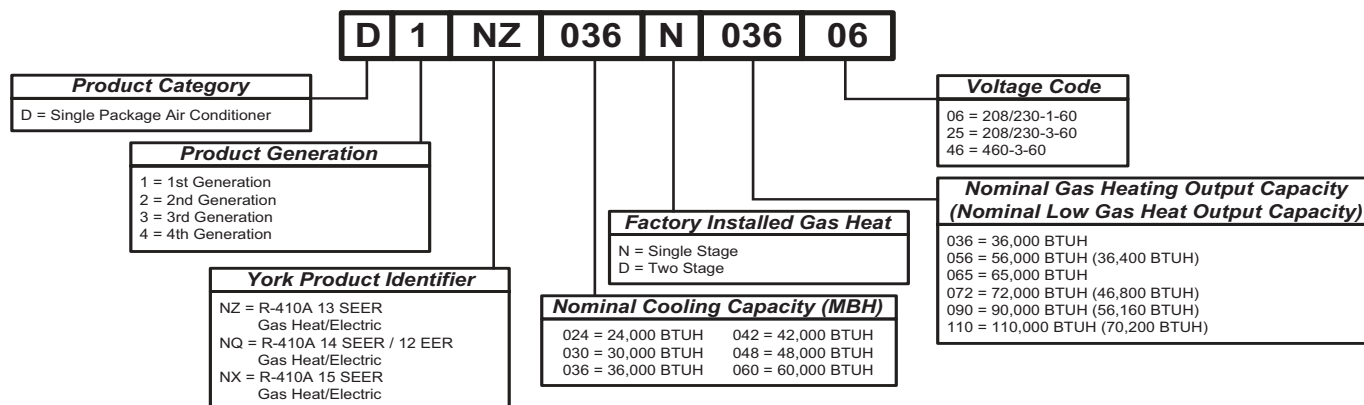

Features and Benefits

Standard Features

- **Operating Efficiency** - All gas units provide a minimum AFUE of 80% and SEERS of 13.0 to 16.5. All efficiencies exceed legislated minimum levels.
- **On Site Flexibility** - All model sizes share a common, compact design cabinet in a single footprint. The installer has the flexibility of setting one curb and placing the proper tonnage unit on that curb after the internal load has been determined. Field convertible duct connections from side shot to down shot allows the installer to have greater flexibility with less inventory.
- **Lower Installation Cost** - Installation time and costs are reduced by easy power and control wiring connections. The small base dimension means less space is required on the ground or roof, plus, the installer can fit this unit between the wheel wells of full size pick-up truck.

All units are completely wired, charged with R-410A and tested prior to shipment. Unique test stations using a new state of the art computerized process system are used to insure product quality. Refrigerant charge and component part numbers are verified via computers at assembly. Vital run test statistics such as system pressure, motor currents, air velocity and temperature, unit vibration, and gas system safeties are monitored and recorded by the system to insure unit performance.

Equal size, side supply and return duct connections allows easy hook-up of ducts to match low crawl spaces without transition pieces.

- **Utility Connections Made Easy** - Gas and electric utility knockouts are provided through the bottom as well as the side of the unit. Utility connections can be made quickly and with a minimum amount of field labor. A field supplied and field installed electrical disconnect switch must be installed.
- **Convertible Airflow Design** - The bottom duct openings are covered when they leave the factory ready to be used

for a side supply/side return application. If a bottom supply/bottom return application is desired, you simply remove the two panels from the bottom of the unit and place them in the side supply/side return duct openings. No panel cutting is required and no accessory panel is necessary. Convertible airflow design allows maximum field flexibility and minimum inventory.

- **Condensate Pan** - A non-corrosive, long-lasting, water-tight pan is positioned below the evaporator coil to collect and drain all condensate. Less collection of stagnate condensate will build-up. The condensate pan conforms to ASHRAE 62-89 standards (Ventilation for Acceptable Indoor Air Quality).
- **Condensate Drain** - The 3/4 inch NPTF connection is rigidly mounted to assure proper fit and leak tight seal.
- **Durable Finish** - With a heavy duty cabinet made of powder-painted, galvanized steel the neutral color blends into surrounding areas. The powdered paint provides a better paint to steel bond, which resists corrosion and rust creep. The special primer formulas and glossy finish insures less fading when exposed to sunlight and offers a more attractive on site appearance. This paint finish meets ASTM-B117 standards for 1000 hours salt spray rating. The highest in the industry.
- **Full Perimeter Base Rails** - The easily removable base rails provide a solid foundation for the entire unit and protects the unit during shipment. The rails provide fork lift access from all sides, and rigging holes are also provided so that an overhead crane can be used to place the units on a roof. On applications where the unit is placed on a pad, the base will keep the unit off the pad to deter corrosion. On applications where height is limited, the inch high base rails may be removed on location.
- **More Attractive Appearance** - A single piece Water Shed top cover containing a top discharge condenser fan arrangement requires less square footage on installation and provides a wider variety of installations. The one piece design adds greater water integrity. Rounded

corners with water drip edges add to the attractive appearance. The cabinet panels have a non-fibrous insulation that will not release insulation fibers into conditioned area.

- **Top Discharge** - The top discharge condenser fan does not disrupt neighboring areas or dry-out vegetation surrounding the unit. The warm air from the top mounted fan is blown up away from the structure and any landscaping. This allows compact location on multi-unit applications.
- **Condenser Coil Grille** - All 13 SEER models and 5 ton 14 SEER / 12 EER models utilize a decorative "Wire Form" coil guard to provide impact protection against large objects. The remaining higher SEER models utilize a stamped "Louvered" design which provides superior impact protection against smaller objects during transit and after installation.
- **Low Operating Sound Level** - The upward air flow carries the normal operating noise up and away from the living area. The rigid top panel effectively isolates any motor sound. Isolator mounted compressor and the rippled fins of the condenser coil muffle the normal fan motor and compressor operating sounds. The unique formed base pan also aids in sound alterations with it's Super-Structure design. This design strategically places embossments in the pan for optimum strength and rigidity.
- **Fan System** - All models operate over a wide range of design conditions with an electrically commutated fan motor. These units easily match all types of applications and provide greater on site flexibility to match comfort requirement. The cooling speed is factory set and can be field adjusted to a second speed. The heating speed is factory set to maintain mid point rise at the units heating input, but can be field adjusted. This allows maximum comfort conditions.
- **Simple Control Circuit** - A low voltage printed circuit board contains a diagnostic indicator light and a low voltage terminal strip. An additional set of pin connectors is also provided to simplify the field interface of external controls. Mate-n-lock plug connectors are used. The electrical control box is not located in the compressor compartment. The controls are mounted on a Control-Tilt control panel to allow the access cover to be removed for trouble shooting and maintenance without affecting the normal system operating pressures. All wiring internal to the unit is color/number coded.
- **Protected Compressor** - The compressor is internally protected against high pressure and temperature. This is accomplished by the simultaneous operation of high pressure relief valve and a temperature sensor which protect the compressor if undesirable operating conditions occur.
- **Pressure Switches** - High pressure and low pressure/loss of charge switches standard in all units. When abnormal conditions are sensed through the pressure switches, the unit will lock out preventing any further operation until reset or problem is corrected.
- **Exclusive Coil Design** - Grooved copper tubes and enhanced aluminum fin construction improves heat transfer for maximum efficiency and durability or Micro-Channel aluminum tube, aluminum fin for long lasting durability and efficient operation.
- **Heat Exchangers** - Are corrosion-resistant, aluminized-steel tubular construction to provide long-life, trouble-free operation. The unique blow-through design also assures that condensate does not collect in humid areas when in the cooling cycle. This adds to longer heat exchanger life and higher long term efficiencies.
- **Post Purge Induced Draft Combustion** - Exhausts combustion products from the heat exchanger upon completion of the heating cycle to prolong the heat exchanger life.
- **Self Diagnostic Fan Control Module** - Due to this self diagnostic control, less on site time is required to trouble shoot these units.
- **Spark To Pilot Ignition** - Provides faster heat delivery. This ignition is highly reliable, durable and eliminates nuisance lockouts.
- **Multi Port In-shot Burners** - No field adjustment is required to mix the air and gas. These burners are constructed of high-grade corrosion-resistant, aluminized-steel.
- **Low Maintenance** - Long life, permanently lubricated condenser and evaporator fan motor bearings need no annual maintenance adding greater reliability to the unit. Blower assembly can be easily cleaned by the unique Slip-Track slide-out blower assembly.
- **Secured Service Access Ports** - Protected, externally mounted, re-usable service access ports are provided on both the high and low lines for ease of evacuating and charging the system. No final field mounting required.
- **Easy Service Access** - A large, single panel covers the electrical and gas controls makes servicing easy. The blower compartment has an additional large panel with a built-in handle tab. Removing this panel will allow the blower assembly to slide-out for easy removal for maintenance and ease of trouble shooting.
- **Replacement Parts** - The installer requires no special training to replace any of the components of these units and does not need to maintain an inventory of unique parts.
- **System Integration** - Each unit has the internal ability to integrate an electronic air cleaner or humidifier to work in conjunction with the base unit.

Field Installed Accessories

- **Low NOx Kit** - Kit includes all the necessary hardware and instructions to field convert units to reduce emissions to less than 40 nanogram per Joule. California requirement on single phase models only.
- **Propane Conversion Kit** - Kit includes burner orifices, gas valve conversion and installation instructions necessary to field convert unit from natural gas to propane.
- **High Altitude Conversion Kit (Natural Gas/Propane)** - Kit includes all necessary labels and instructions to field alter

units with natural gas/propane for installations above 2000 feet. Burner orifices must be obtained from Source 1 Parts. Propane Conversion Kit must be obtained separately.

- **Economizer Down Discharge/Supply Kit** - Modulating integrated economizer provides simultaneous operation between the mechanical cooling and economizer operation. Independent blade design insures proper control and less than 1% leak rate. Includes hood and mesh bird screen filter integrated into the hood, dry bulb sensor and relief damper. Separate field accessories of single enthalpy and dual enthalpy are also available. A built-in barometric relief of 25% is provided.
- **Single Enthalpy Sensor** - Sensor replaces dry bulb sensor standard in economizer kit. Provides improved economizer operation by sensing the dry bulb temperature from outdoors plus the enthalpy content of the outdoor air.
- **Dual Enthalpy Sensor** - Additional sensor to single enthalpy sensor. Sensor senses both the return air temperature dry bulb and humidity in conjunction with the single enthalpy to determine the most economical mix. Single Enthalpy sensor also required.
- **Hail Guard Kit** - Kit contains protective grilles made of expanded aluminum with full perimeter frame. Sloped hoods are also included to assure maximum protection.
- **Anti Short Cycle Timer (DNZ Units Only)** - Automatically prevents the compressor from restarting for 5 minutes after cycled off. Not required if Thermostat 2ET07700224 and 2ET04700224 are used. Standard in all DNX and DNQ units.
- **Filter/Frame Kit (Single Phase Only)** - Kit contains the necessary hardware to field install return air filters into the base unit. Pre-cut filter racks and appropriate cleanable standard size filters are shipped in one kit. The filter rack is suitable for either 1" or 2" filters. (1" filter is supplied) This kit is available for single phase horizontal or vertical duct application only. Standard in all 3 Phase models.
- **Motorized Fresh Air Damper** - Designed for duct mounted side supply/return and unit mounted down supply/return applications. Damper capable of providing 0% through 50% of outdoor air (field supplied). Closes on power loss, includes hood and screen assembly.
- **Rectangle To Round Adapters** - Kit includes one supply and one return air rectangle to round duct adapter. Adapters are preformed and designed to fit over current duct openings on the base unit. Transition is from side square duct opening to 14" round duct opening.
- **Roof Curbs** - NRCA approved curbs provide proper fit to base unit for rooftop installations. Curbs are designed to be assembled through hinge pins in each corner. Kit also provides seal strip to assure a water tight seal. 8 and 14 inch high roof curbs are available.
- **Manual Outdoor Damper** - Provides 0% through 50% outdoor air capability (field adjustable). Designed for duct mounted side supply/return applications. Includes hood and screen assembly.

- **Wall Thermostat** - The units are designed to operate with 24-volt electronic and electro-mechanical thermostats. All units can operate with single stage heat/single stage cool thermostats - with or without the economizer.
- **Low Ambient Kit** - Kit provides necessary hardware to convert unit to operate in cooling cycle down to 0° F. Standard unit operation 45° F.
- **Transformer Kit** - Kit provides necessary hardware to provide single phase models from factory furnished 40 VA transformer capability to 75 VA transformer capability. (Required on installations with economizer or motorized damper.)

Guide Specifications

General

Units shall be manufactured by Unitary Products in an ISO 9001 certified facility. YORK's Affinity™ package units give you the flexibility and choices you need in today's market. These packaged cooling/heating air conditioners are designed for outdoor installation. Only utility and duct connections are required at the point of installation. The single or two stage gas fired heaters have aluminized steel tubular heat exchangers and spark to pilot ignition. They are available in natural gas with field conversion to propane.

Description

Units shall be factory-assembled, single packaged, Electric Cooling/Gas Heating units, designed for outdoor mounted installation. For SEER ratings, refer to technical literature. They shall have built in, equal size, field convertible duct connections for down discharge supply/return or horizontal discharge supply/return. The units shall be factory wired, piped, charged with R-410A Refrigerant and factory tested prior to shipment. All unit wiring shall be both numbered and color coded. All units shall be manufactured in a facility certified to ISO 9001 standards, and the cooling performance shall be rated in accordance with DOE and ARI test procedures. The heating performance shall be rated to DOE and GAMA test procedures. Units shall be CSA listed and classified to ANSI Z21.47/CAN/CSA 2.3 standards and UL 1995/CAN/CSA No. 236-M90 conditions.

Unit Cabinet

Unit cabinet shall be constructed of galvanized steel, with exterior surfaces coated with a non-chalking, powdered paint finish, certified at 1000 hours salt spray test per ASTM-B117 standards. The unit top shall be a single piece "Water Shed" design, with drip edges and no-seam corners to provide optimum water integrity. Unit shall have a rigidly mounted condenser coil guard to provide protection from objects and personnel after installation. Indoor blower section shall be insulated with up to 3/4" thick, aluminum, foil faced insulation, fastened to prevent insulation from entering the air stream. Cabinet panels shall be "large" size, easily removable for servicing and maintenance, with built-in lift handles. Unit shall be built on a formed, "Super-Structure" design base pan, with

embossments at critical points to add strength, rigidity and aid in minimizing sound. Full perimeter base rails shall be provided to assure reliable transit of equipment, overhead rigging, for truck access and proper sealing on roof curb applications. Base rails shall be removable, when required, to lower unit height. Filters shall be furnished and be accessible through a removable access door, sealed airtight. Units vertical discharge and return duct configuration shall be designed to fit between standard 24" O.C. beams without modification to building structure, duct work and base unit. Condensate pan shall be internally sloped and conform to ASHRAE 62-89 self-draining standards, with 3/4" NPTF rigid mount connection.

Indoor (Evaporator) Fan Assembly

Fan shall be direct drive design. Fan wheel shall be double-inlet type with forward-curved blades, dynamically balanced to operate smoothly throughout the entire range of operation. Airflow design shall be constant air volume. Bearings shall be sealed and permanently lubricated for longer life and no maintenance. Fan assembly shall be "Slip Track" (slide-out) design for easy removal and cleaning.

Outdoor (Condenser) Fan Assembly

The outdoor fan shall be of the direct-driven propeller type, discharge air vertically, have aluminum blades riveted to corrosion resistant steel spider bracket and shall be statically balanced for smooth operation. The outdoor fan motor shall be totally enclosed with permanently lubricated bearings and internally protected against overload conditions.

Refrigerant Components

Compressors:

- a. Shall be fully hermetic type, direct drive, internally protected with internal high-pressure relief and over temperature protection. The hermetic motor shall be suction gas cooled and have a voltage range of +/- 10% of the unit nameplate voltage.
- b. Shall have internal isolation and sound muffling to minimize vibration and noise, and be externally isolated on a dedicated, independent mounting.

Coils:

- a. Evaporator coils shall have aluminum plate fins mechanically bonded to seamless internally enhanced copper tubes with all joints brazed.
- b. Evaporator coil shall be of the direct expansion, blow through design.
- c. Condenser coils shall have aluminum plate fins mechanically bonded to seamless internally enhanced copper tubes with all joints brazed or Micro-Channel aluminum tube, aluminum fins.
- d. Condenser coil shall be draw through design.

Refrigerant Circuit and Refrigerant Safety Components shall include:

- a. Shall include independent fixed orifice expansion devices.
- b. Shall include filter/strainer to eliminate any foreign matter.

Gas Heating Section (If Equipped)

Heat exchanger and exhaust system shall be constructed of aluminized steel and shall be designed with induced draft combustion with post purge logic and redundant main gas valve. The heat exchanger shall be of the tubular type, constructed of T1-40 aluminized steel for corrosion resistance and allowing minimum mixed air entering temperature of 40 °F. Burners shall be of the in-shot type, constructed of aluminum-coated steel. All gas piping shall enter the unit cabinet at a single location through either the side or bottom, without any field modifications. An integrated control board shall provide timed control of evaporator fan functioning and burner ignition. Heating section shall be provided with the following minimum protection:

- a. Primary and auxiliary high-temperature limit switches.
- b. Induced draft pressure sensor.
- c. Flame roll out switch (manual reset).
- d. Flame proving controls.

DNQ024-060 Single Stage Gas Heat

Component	Models														
	DNQ024		DNQ030		DNQ036		DNQ042		DNQ048		DNQ060				
Nominal Tonnage	2.0	2.5	3.0	3.5	4.0	5.0									
ARI COOLING PERFORMANCE															
Gross Capacity @ ARI A point (MBh)	24.0	29.8	35.7	43.5	49.6	59.6*									
ARI net capacity (MBh)	23.5	29.0	34.5	42.0	48.0	55.0*									
EER	12.0	12.0	12.0	12.0	12.0	12.0*									
SEER	14.0	14.0	14.0	14.0	14.0	14.0*									
Nominal CFM	800	900	1100	1400	1500	1550									
System power (KW)	2.0	2.4	2.9	3.5	4.0	4.6									
Refrigerant type	R-410A	R-410A	R-410A	R-410A	R-410A	R-410A									
Refrigerant charge (lb-oz)	3-8	3-15	4-4	5-4	5-0	6-5									
ARI HEATING PERFORMANCE															
Heating model	N036	N056	N036	N056	N036	N056	N072	N065	N090	N065	N090	N110	N065	N090	N110
Heat input (K Btu)	45	70	45	70	45	70	90	80	108	80	108	135	80	108	135
Heat output (K Btu)	38	56	36	56	36	56	72	64	87	64	87	108	64	87	108
AFUE %	80.0	80.0	80.0	80.0	80.0	80.0	80.0	80.0	80.0	80.0	80.0	80.0	80.0	80.0	80.0
Steady state efficiency (%)	80	80	80	80	80	80	80	80	80	80	80	80	80	80	80
No. burners	2	3	2	3	2	3	4	3	4	3	4	5	3	4	5
No. stages	1	1	1	1	1	1	1	1	1	1	1	1	1	1	1
Temperature Rise Range (°F)	25-55	30-60	25-55	30-60	25-55	25-55	30-60	25-55	45-75	25-55	35-65	45-75	25-55	35-65	45-75
Gas Limit Setting (°F)	140	160	140	160	140	160	160	140	160	150	175	160	150	175	160
Gas piping connection (in.)	1/2		1/2		1/2			1/2		1/2			1/2		
DIMENSIONS (inches)															
Length	49 1/8		49 1/8		49 1/8			49 1/8		49 1/8			49 1/8		
Width	47 1/4		47 1/4		47 1/4			47 1/4		47 1/4			47 1/4		
Height	33 1/2		33 1/2		33 1/2			41 1/2		41 1/2			41 1/2		
OPERATING WT. (lbs.)															
	390		425		430			485		490			530		
COMPRESSORS															
Type	Recip 1-spd		Scroll 1-spd		Scroll 1-spd			Scroll 1-spd		Scroll 1-spd			Scroll 1-spd		
Quantity	1		1		1			1		1			1		
CONDENSER COIL DATA															
Face area (Sq. Ft.)	7.9		11.9		11.9			15		15			15		
Rows	1		1		1			1		1			1		
Fins per inch	23		23		23			23		23			23		
Tube diameter (in./MM)	0.71/18		0.71/18		0.71/18			0.71/18		0.71/18			0.98/25		
Circuitry Type	2-pass		2-pass		2-pass			2-pass		2-pass			2-pass		
EVAPORATOR COIL DATA															
Face area (Sq. Ft.)	3.4		3.4		3.4			4.4		4.4			4.4		
Rows	2		3		3			3		3			4		
Fins per inch	15		13		13			16		16			13		
Tube diameter	3/8		3/8		3/8			3/8		3/8			3/8		
Circuitry Type	Interlaced		Interlaced		Interlaced			Interlaced		Interlaced			Interlaced		
Refrigerant control	TXV		TXV		TXV			TXV		TXV			TXV		
CONDENSER FAN DATA															
Quantity	1		1		1			1		1			1		
Fan diameter (Inch)	22		22		22			22		22			22		
Type	Prop		Prop		Prop			Prop		Prop			Prop		
Drive type	Direct		Direct		Direct			Direct		Direct			Direct		
No. speeds	1		1		1			1		1			1		
Number of motors	1		1		1			1		1			1		
Motor HP each	1/4		1/4		1/4			1/3		1/3			1/3		
RPM	1100		1100		1100			1100		1100			1100		
Nominal total CFM	2400		2400		2400			3200		3200			3200		
DIRECT DRIVE EVAP FAN DATA															
Quantity	1		1		1			1		1			1		
Fan Size (Inch)	10 x 8		10 x 8		11 x 10			12 x 11		12 x 11			12 x 11		
Type	Centrifugal		Centrifugal		Centrifugal			Centrifugal		Centrifugal			Centrifugal		
Motor HP each	1/2		3/4		3/4			1		1			1		
RPM	Variable		Variable		Variable			Variable		Variable			Variable		
Frame size	48		48		48			48		48			48		
FILTERS															
Quantity - Size	1 - 20 x 20 x 1		1 - 20 x 20 x 1		1 - 20 x 20 x 1			2 - 20 x 20 x 1		2 - 20 x 12 x 1			2 - 20 x 12 x 1		

* Rating established with a "Wire Form" coil guard which ships as standard.

DNQ024-060 Two Stage Gas Heat

Component	Models								
	DNQ024	DNQ030	DNQ036	DNQ042	DNQ048	DNQ060			
Nominal Tonnage	2.0	2.5	3.0	3.5	4.0	5.0			
ARI COOLING PERFORMANCE									
Gross Capacity @ ARI A point (MBh)	24.0	29.8	35.7	43.5	49.6	56.8*			
ARI net capacity (MBh)	23.5	29.0	34.5	42.0	48.0	55.0*			
EER	12.0	12.0	12.0	12.0	12.0	12.0*			
SEER	14.0	14.0	14.0	14.0	14.0	14.0*			
Nominal CFM	800	900	1100	1400	1500	1550			
System power (KW)	2.0	2.4	2.9	3.5	4.0	4.6			
Refrigerant type	R-410A	R-410A	R-410A	R-410A	R-410A	R-410A			
Refrigerant charge (lb-oz)	3-8	3-15	4-4	5-4	5-0	6-5			
ARI HEATING PERFORMANCE									
Heating model	D056	D056	D056	D072	D090	D090	D110	D090	D110
Heat input (K Btu)	70/45.5	70/45.5	70/45.5	90/58.5	108/70.2	108/70.2	135/87.8	108/70.2	135/87.8
Heat output (K Btu)	56/36.4	56/36.4	56/36.4	72/46.8	87/56.2	87/56.2	108/70.2	87/56.2	108/70.2
AFUE %	80.0	80.0	80.0	80.0	80.0	80.0	80.0	80.0	80.0
Steady state efficiency (%)	80	80	80	80	80	80	80	80	80
No. burners	3	3	3	4	4	4	5	4	5
No. stages	2	2	2	2	2	2	2	2	2
Temperature Rise Range (°F)	30-60	30-60	25-55	30-60	45-75	35-65	45-75	35-65	45-75
Gas Limit Setting (°F)	160	160	160	160	175	175	170	175	170
Gas piping connection (in.)	1/2	1/2	1/2	1/2	1/2	1/2	1/2	1/2	1/2
DIMENSIONS (inches)									
Length	49 1/8	49 1/8	49 1/8	49 1/8	49 1/8	49 1/8	49 1/8	49 1/8	49 1/8
Width	47 1/4	47 1/4	47 1/4	47 1/4	47 1/4	47 1/4	47 1/4	47 1/4	47 1/4
Height	33 1/2	33 1/2	33 1/2	33 1/2	41 1/2	41 1/2	41 1/2	41 1/2	41 1/2
OPERATING WT. (lbs.)									
	390	425	430	485	490	530			
COMPRESSORS									
Type	Recip 1-spd	Scroll 1-spd	Scroll 1-spd	Scroll 1-spd	Scroll 1-spd	Scroll 1-spd	Scroll 1-spd	Scroll 1-spd	Scroll 1-spd
Quantity	1	1	1	1	1	1	1	1	1
CONDENSER COIL DATA									
Face area (Sq. Ft.)	7.9	11.9	11.9	15	15	15	15	15	15
Rows	1	1	1	1	1	1	1	1	1
Fins per inch	23	23	23	23	23	23	23	23	23
Tube diameter (in./MM)	0.71/18	0.71/18	0.71/18	0.71/18	0.71/18	0.71/18	0.71/18	0.98/25	0.98/25
Circuitry Type	2-pass	2-pass	2-pass	2-pass	2-pass	2-pass	2-pass	2-pass	2-pass
EVAPORATOR COIL DATA									
Face area (Sq. Ft.)	3.4	3.4	3.4	4.4	4.4	4.4	4.4	4.4	4.4
Rows	2	3	3	3	3	3	3	4	4
Fins per inch	15	13	13	16	16	16	16	13	13
Tube diameter	3/8	3/8	3/8	3/8	3/8	3/8	3/8	3/8	3/8
Circuitry Type	Interlaced	Interlaced	Interlaced	Interlaced	Interlaced	Interlaced	Interlaced	Interlaced	Interlaced
Refrigerant control	TXV	TXV	TXV	TXV	TXV	TXV	TXV	TXV	TXV
CONDENSER FAN DATA									
Quantity	1	1	1	1	1	1	1	1	1
Fan diameter (Inch)	22	22	22	22	22	22	22	22	22
Type	Prop	Prop	Prop	Prop	Prop	Prop	Prop	Prop	Prop
Drive type	Direct	Direct	Direct	Direct	Direct	Direct	Direct	Direct	Direct
No. speeds	1	1	1	1	1	1	1	1	1
Number of motors	1	1	1	1	1	1	1	1	1
Motor HP each	1/4	1/4	1/4	1/3	1/3	1/3	1/3	1/3	1/3
RPM	1100	1100	1100	1100	1100	1100	1100	1100	1100
Nominal total CFM	2400	2400	2400	3200	3200	3200	3200	3200	3200
DIRECT DRIVE EVAP FAN DATA									
Quantity	1	1	1	1	1	1	1	1	1
Fan Size (Inch)	10 x 8	10 x 8	11 x 10	12 x 11	12 x 11	12 x 11	12 x 11	12 x 11	12 x 11
Type	Centrifugal	Centrifugal	Centrifugal	Centrifugal	Centrifugal	Centrifugal	Centrifugal	Centrifugal	Centrifugal
Motor HP each	1/2	3/4	3/4	1	1	1	1	1	1
RPM	Variable	Variable	Variable	Variable	Variable	Variable	Variable	Variable	Variable
Frame size	48	48	48	48	48	48	48	48	48
FILTERS									
Quantity - Size	1 - 20 x 20 x 1	1 - 20 x 20 x 1	1 - 20 x 20 x 1	2 - 20 x 20 x 1	2 - 20 x 12 x 1	2 - 20 x 12 x 1	2 - 20 x 12 x 1	2 - 20 x 12 x 1	2 - 20 x 12 x 1

* Rating established with a "Wire Form" coil guard which ships as standard.

DNZ, DNQ and DNX Unit Limitations

Size (Tons)	Model	Unit Voltage	Unit Limitations		
			Applied Voltage		Outdoor DB Temp
			Min	Max	Max (°F)
024 (2.0)	DNZ DNQ	208/230-1-60	187	252	125
	DNX	208/230-1-60	187	252	115
030 (2.5)	DNZ	208/230-1-60	187	252	125
		208/230-3-60	187	252	125
		460-3-60	432	504	125
	DNQ	208/230-1-60	187	252	115
		208/230-3-60	187	252	115
		460-3-60	432	504	115
036 (3.0)	DNZ	208/230-1-60	187	252	125
		208/230-3-60	187	252	125
		460-3-60	432	504	125
	DNQ DNX	208/230-1-60	187	252	115
		208/230-3-60	187	252	115
		460-3-60	432	504	115
042 (3.5)	DNZ DNQ	208/230-1-60	187	252	125
		208/230-3-60	187	252	125
		460-3-60	432	504	125
048 (4.0)	DNZ DNQ DNX	208/230-1-60	187	252	115
		208/230-3-60	187	252	115
		460-3-60	432	504	115
060 (5.0)	DNQ	208/230-1-60	187	252	125
		208/230-3-60	187	252	125
		460-3-60	432	504	125
	DNZ	208/230-1-60	187	252	115
		208/230-3-60	187	252	115
		460-3-60	432	504	115

DNQ024-060 Cooling Capacities

DNQ024 (2.0 Ton)

Air on Evaporator Coil		Temperature of Air on Condenser Coil																	
CFM	WB (°F)	Net Capacity ¹ (MBh)	Total Input (kW) ²	Sensible Capacity (MBh)						Net Capacity ¹ (MBh)	Total Input (kW) ²	Sensible Capacity (MBh)							
				Return Dry Bulb (°F)								Return Dry Bulb (°F)							
				90	85	80	75	70	65			90	85	80	75	70	65		
		75°F									85°F								
600	77	34.0	1.5	10.5	8.0	5.6	-	-	-	30.5	1.7	11.9	9.4	6.9	-	-	-		
	72	30.5	1.5	16.4	14.0	11.5	9.1	-	-	27.7	1.7	16.7	14.2	11.7	9.3	-	-		
	67	27.0	1.6	22.3	19.9	17.5	15.0	12.6	-	25.0	1.7	21.5	19.0	16.5	14.1	11.6	-		
	62	24.4	1.6	24.4	19.7	17.0	14.5	12.1	9.7	22.6	1.7	22.6	20.3	17.8	15.3	12.8	10.4		
	57	25.1	1.6	25.1	21.5	18.8	16.4	13.9	11.5	22.9	1.7	22.9	21.2	18.7	16.2	13.7	11.3		
700	77	35.0	1.5	12.7	9.5	6.8	-	-	-	31.5	1.7	13.8	10.7	7.9	-	-	-		
	72	31.4	1.5	19.1	16.4	13.8	11.1	-	-	28.6	1.7	18.9	16.2	13.4	10.7	-	-		
	67	27.8	1.6	25.4	23.4	20.8	18.1	15.5	-	25.7	1.7	24.0	21.7	18.9	16.2	13.4	-		
	62	25.0	1.6	25.0	22.7	20.3	17.7	15.1	12.4	23.3	1.7	23.3	22.1	20.3	17.6	14.8	12.1		
	57	25.8	1.6	25.8	24.0	22.4	19.8	17.1	14.5	23.7	1.7	23.7	22.8	21.4	18.6	15.9	13.1		
800	77	35.9	1.5	15.0	10.9	8.0	-	-	-	32.4	1.7	15.8	11.9	8.9	-	-	-		
	72	32.2	1.6	21.8	18.9	16.0	13.2	-	-	29.5	1.7	21.1	18.1	15.1	12.1	-	-		
	67	28.5	1.6	28.5	26.9	24.1	21.2	18.3	-	26.5	1.7	26.5	24.3	21.3	18.3	15.3	-		
	62	25.7	1.6	25.7	25.7	23.7	20.9	18.0	15.2	24.0	1.7	24.0	24.0	22.9	19.9	16.9	13.8		
	57	26.4	1.6	26.4	26.4	26.1	23.2	20.4	17.5	24.4	1.7	24.4	24.4	24.1	21.1	18.0	15.0		
900	72	33.0	1.5	22.3	18.9	15.5	12.1	-	-	29.8	1.7	21.9	18.5	15.1	11.7	-	-		
	67	29.2	1.6	29.2	26.7	23.4	20.0	16.6	-	26.8	1.7	26.8	24.7	21.3	17.9	14.5	-		
	62	26.3	1.6	26.3	26.3	23.7	20.3	16.9	13.6	24.3	1.7	24.3	24.3	22.9	19.5	16.1	12.7		
	57	27.1	1.6	27.1	27.1	26.1	22.7	19.3	15.9	24.6	1.7	24.6	24.6	24.1	20.7	17.3	13.9		
			95°F									105°F							
600	77	27.0	1.9	13.3	10.8	8.3	-	-	-	25.1	2.0	13.3	10.4	7.9	-	-	-		
	72	25.0	1.9	17.0	14.5	12.0	9.4	-	-	22.7	2.0	16.3	13.7	11.2	8.7	-	-		
	67	22.9	1.9	20.7	18.2	15.6	13.1	10.6	-	20.4	2.0	19.2	17.1	14.6	12.1	9.6	-		
	62	20.8	1.8	20.8	20.8	18.6	16.1	13.6	11.0	19.0	2.0	19.0	19.0	16.9	14.4	11.9	9.4		
	57	20.8	1.8	20.8	20.8	18.6	16.1	13.6	11.1	19.1	2.0	19.1	19.1	17.0	14.5	12.0	9.4		
800	77	27.9	1.9	14.9	11.9	9.0	-	-	-	25.8	2.0	15.4	11.5	8.6	-	-	-		
	72	25.8	1.9	18.8	15.9	13.1	10.2	-	-	23.3	2.0	17.9	15.0	12.2	9.4	-	-		
	67	23.7	1.9	22.6	19.9	17.1	14.3	11.4	-	20.9	2.0	20.3	18.6	15.9	13.1	10.3	-		
	62	21.6	1.8	21.6	21.6	20.3	17.5	14.6	11.8	19.6	2.0	19.6	19.6	18.4	15.6	12.8	10.0		
	57	21.6	1.8	21.6	21.6	20.3	17.5	14.6	11.8	19.6	2.0	19.6	19.6	18.5	15.7	12.9	10.0		
800	77	28.9	1.9	16.5	13.0	9.8	-	-	-	26.4	2.1	17.4	12.6	9.2	-	-	-		
	72	26.7	1.9	20.5	17.3	14.2	11.0	-	-	23.9	2.0	19.4	16.3	13.2	10.1	-	-		
	67	24.5	1.9	24.5	21.7	18.6	15.4	12.2	-	21.4	2.0	21.4	20.1	17.2	14.1	11.0	-		
	62	22.3	1.8	22.3	22.3	22.0	18.9	15.7	12.5	20.1	2.0	20.1	20.1	19.9	16.8	13.7	10.6		
	57	22.3	1.8	22.3	22.3	22.1	18.9	15.7	12.5	20.1	2.0	20.1	20.1	20.0	16.9	13.8	10.6		
900	72	26.6	1.9	21.5	18.1	14.7	11.3	-	-	24.0	2.0	20.4	17.0	13.7	10.4	-	-		
	67	24.4	1.9	24.4	22.7	19.3	15.8	12.4	-	21.5	2.0	21.5	20.6	17.8	14.5	11.2	-		
	62	22.2	1.8	22.2	22.2	22.1	18.7	15.3	11.9	20.1	2.0	20.1	20.1	20.0	16.7	13.3	10.0		
	57	22.2	1.8	22.2	22.2	22.1	18.7	15.3	11.9	20.2	2.0	20.2	20.2	20.1	16.7	13.4	10.1		

DNQ024 (2.0 Ton) (Continued)

Air on Evaporator Coil		Temperature of Air on Condenser Coil															
CFM	WB (°F)	Net Capacity ¹ (MBh)	Total Input (kW) ²	Sensible Capacity (MBh)						Net Capacity ¹ (MBh)	Total Input (kW) ²	Sensible Capacity (MBh)					
				Return Dry Bulb (°F)								Return Dry Bulb (°F)					
				90	85	80	75	70	65			90	85	80	75	70	65
				115°F						125°F							
600	77	23.2	2.2	13.2	10.0	7.5	-	-	-	21.3	2.4	14.3	9.5	7.0	-	-	-
	72	20.5	2.2	15.5	13.0	10.5	8.0	-	-	18.3	2.3	14.8	12.3	9.8	7.3	-	-
	67	17.8	2.1	17.8	16.1	13.6	11.1	8.6	-	15.3	2.3	15.3	15.0	12.5	10.1	7.6	-
	62	17.3	2.1	17.3	17.3	15.3	12.8	10.3	7.8	15.5	2.2	15.5	15.5	13.6	11.1	8.6	6.1
	57	17.4	2.1	17.4	17.4	15.3	12.8	10.3	7.8	15.7	2.2	15.7	15.7	13.7	11.2	8.7	6.2
700	77	23.6	2.2	15.8	11.1	8.1	-	-	-	21.4	2.4	16.8	11.4	7.6	-	-	-
	72	20.9	2.2	16.9	14.2	11.4	8.6	-	-	18.4	2.3	16.0	13.3	10.6	7.8	-	-
	67	18.1	2.1	18.1	17.2	14.7	11.9	9.1	-	15.3	2.3	15.3	15.3	13.5	10.8	8.0	-
	62	17.5	2.1	17.5	17.5	16.5	13.8	11.0	8.2	15.5	2.3	15.5	15.5	14.7	11.9	9.2	6.4
	57	17.7	2.1	17.7	17.7	16.6	13.8	11.1	8.3	15.7	2.2	15.7	15.7	14.8	12.0	9.3	6.5
800	77	24.0	2.2	18.4	12.2	8.7	-	-	-	21.5	2.4	19.3	13.3	8.1	-	-	-
	72	21.2	2.2	18.4	15.3	12.3	9.2	-	-	18.4	2.3	17.3	14.3	11.3	8.3	-	-
	67	18.4	2.1	18.4	18.4	15.8	12.8	9.7	-	15.3	2.3	15.3	15.3	14.5	11.5	8.5	-
	62	17.8	2.1	17.8	17.8	17.8	14.8	11.7	8.6	15.6	2.3	15.6	15.6	15.6	12.7	9.7	6.7
	57	18.0	2.1	18.0	18.0	17.9	14.8	11.8	8.7	15.8	2.3	15.8	15.8	15.8	12.8	9.8	6.8
900	72	21.3	2.2	19.2	16.0	12.7	9.4	-	-	18.7	2.3	18.1	14.9	11.7	8.5	-	-
	67	18.5	2.2	18.5	18.5	16.4	13.1	9.9	-	15.6	2.3	15.6	15.6	15.0	11.8	8.6	-
	62	17.9	2.1	17.9	17.9	17.9	14.7	11.4	8.2	15.8	2.3	15.8	15.8	15.8	12.7	9.5	6.3
	57	18.1	2.1	18.1	18.1	18.1	14.8	11.5	8.3	16.1	2.3	16.1	16.1	16.1	12.9	9.7	6.5

1. These capacities are Net Capacities.
2. These ratings include the compressor, condenser fan and supply air blower motors.

DNQ030 (2.5 Ton)

Air on Evaporator Coil		Temperature of Air on Condenser Coil															
CFM	WB (°F)	Net Capacity ¹ (MBh)	Total Input (kW) ²	Sensible Capacity (MBh)						Net Capacity ¹ (MBh)	Total Input (kW) ²	Sensible Capacity (MBh)					
				Return Dry Bulb (°F)								Return Dry Bulb (°F)					
				90	85	80	75	70	65			90	85	80	75	70	65
				75°F						85°F							
900	77	37.7	1.7	19.0	15.4	11.9	-	-	-	36.6	1.9	18.7	15.1	11.5	-	-	-
	72	35.1	1.7	24.4	20.9	17.3	13.8	-	-	33.7	1.9	24.0	20.4	16.8	13.2	-	-
	67	32.5	1.7	29.9	26.3	22.8	19.2	15.7	-	30.9	1.9	29.3	25.7	22.1	18.5	14.9	-
	62	30.4	1.7	30.4	30.4	27.9	24.3	20.8	17.2	29.1	1.9	29.1	29.1	26.8	23.2	19.6	16.0
	57	30.0	1.7	30.0	30.0	27.7	24.2	20.6	17.1	29.1	1.9	29.1	29.1	27.0	23.4	19.8	16.2
1000	77	39.8	1.7	19.6	17.1	13.3	-	-	-	38.1	1.9	20.5	16.6	12.8	-	-	-
	72	37.0	1.7	26.9	23.2	19.4	15.6	-	-	35.2	1.9	26.4	22.5	18.7	14.8	-	-
	67	34.3	1.7	34.3	29.3	25.5	21.7	17.9	-	32.3	1.9	32.3	28.4	24.6	20.7	16.9	-
	62	32.0	1.7	32.0	32.0	31.2	27.4	23.7	19.9	30.3	1.9	30.3	30.3	29.8	26.0	22.2	18.3
	57	31.6	1.7	31.6	31.6	31.0	27.2	23.5	19.7	30.3	1.9	30.3	30.3	30.0	26.2	22.4	18.5
1125	72	37.3	1.7	28.7	24.5	20.3	16.1	-	-	35.5	1.9	28.1	23.9	19.6	15.3	-	-
	67	34.6	1.7	34.6	30.9	26.7	22.5	18.2	-	32.6	1.9	32.6	30.1	25.8	21.5	17.2	-
	62	32.2	1.7	32.2	32.2	31.9	27.6	23.4	19.2	30.6	1.9	30.6	30.6	30.4	26.1	21.8	17.6
	57	31.9	1.7	31.9	31.9	31.6	27.3	23.1	18.9	30.6	1.9	30.6	30.6	30.5	26.2	21.9	17.7
1250	72	37.6	1.7	30.5	25.8	21.2	16.5	-	-	35.9	1.9	29.9	25.2	20.5	15.8	-	-
	67	34.8	1.7	34.8	32.5	27.8	23.2	18.5	-	32.9	1.9	32.9	31.7	27.0	22.3	17.5	-
	62	32.5	1.7	32.5	32.5	32.5	27.8	23.2	18.5	30.9	1.9	30.9	30.9	30.9	26.2	21.5	16.8
	57	32.1	1.7	32.1	32.1	32.1	27.5	22.8	18.1	30.9	1.9	30.9	30.9	30.9	26.2	21.5	16.8
				95°F						105°F							
900	77	35.4	2.1	18.4	14.8	11.1	-	-	-	33.0	2.4	18.5	14.0	10.3	-	-	-
	72	32.3	2.1	23.6	19.9	16.3	12.7	-	-	30.2	2.4	22.8	19.1	15.5	11.9	-	-
	67	29.3	2.1	28.8	25.1	21.5	17.8	14.2	-	27.3	2.4	27.0	24.3	20.7	17.0	13.4	-
	62	27.8	2.1	27.8	27.8	25.8	22.1	18.5	14.9	26.1	2.4	26.1	26.1	24.1	20.4	16.8	13.2
	57	28.2	2.1	28.2	28.2	26.4	22.7	19.1	15.4	26.7	2.4	26.7	26.7	24.8	21.2	17.6	13.9
1000	77	36.4	2.1	21.3	16.2	12.3	-	-	-	34.0	2.4	21.9	15.4	11.4	-	-	-
	72	33.3	2.1	25.8	21.9	18.0	14.1	-	-	31.0	2.4	25.0	21.1	17.1	13.2	-	-
	67	30.2	2.1	30.2	27.6	23.7	19.8	15.9	-	28.1	2.4	28.1	26.7	22.9	18.9	15.0	-
	62	28.7	2.1	28.7	28.7	28.4	24.5	20.6	16.7	26.8	2.4	26.8	26.8	26.6	22.7	18.8	14.9
	57	29.1	2.1	29.1	29.1	29.1	25.2	21.3	17.4	27.5	2.4	27.5	27.5	27.5	23.5	19.6	15.7
1125	72	33.7	2.1	27.6	23.2	18.9	14.6	-	-	31.3	2.4	26.8	22.4	18.0	13.7	-	-
	67	30.6	2.1	30.6	29.2	24.9	20.6	16.2	-	28.4	2.4	28.4	27.7	24.1	19.7	15.3	-
	62	29.0	2.1	29.0	29.0	28.9	24.6	20.2	15.9	27.1	2.4	27.1	27.1	27.0	22.6	18.2	13.9
	57	29.4	2.1	29.4	29.4	29.4	25.1	20.7	16.4	27.7	2.4	27.7	27.7	27.7	23.4	19.0	14.6
1250	72	34.1	2.1	29.4	24.6	19.8	15.0	-	-	31.7	2.4	28.7	23.8	19.0	14.1	-	-
	67	31.0	2.1	31.0	30.9	26.1	21.3	16.6	-	28.7	2.4	28.7	28.6	25.3	20.4	15.6	-
	62	29.4	2.1	29.4	29.4	29.4	24.6	19.8	15.1	27.4	2.4	27.4	27.4	27.4	22.5	17.7	12.8
	57	29.8	2.1	29.8	29.8	29.8	25.0	20.2	15.4	28.0	2.4	28.0	28.0	28.0	23.2	18.3	13.5

DNQ030 (2.5 Ton) (Continued)

Air on Evaporator Coil		Temperature of Air on Condenser Coil															
CFM	WB (°F)	Net Capacity ¹ (MBh)	Total Input (kW) ²	Sensible Capacity (MBh)						Net Capacity ¹ (MBh)	Total Input (kW) ²	Sensible Capacity (MBh)					
				Return Dry Bulb (°F)								Return Dry Bulb (°F)					
				90	85	80	75	70	65			90	85	80	75	70	65
				115°F						125°F							
900	77	30.7	2.7	18.6	13.1	9.5	-	-	-	28.4	3.0	19.0	12.3	8.7	-	-	-
	72	28.0	2.7	21.9	18.3	14.7	11.1	-	-	25.8	3.0	21.1	17.5	13.9	10.3	-	-
	67	25.2	2.7	25.2	23.5	19.8	16.2	12.6	-	23.1	3.0	23.1	22.6	19.0	15.4	11.8	-
	62	24.3	2.7	24.3	24.3	22.4	18.7	15.1	11.5	22.5	3.0	22.5	22.5	20.6	17.0	13.4	9.8
	57	25.2	2.7	25.2	25.2	23.3	19.7	16.1	12.4	23.7	3.0	23.7	23.7	21.7	18.1	14.5	10.9
1000	77	31.5	2.7	22.5	14.6	10.6	-	-	-	29.1	3.0	23.0	15.1	9.7	-	-	-
	72	28.7	2.7	24.2	20.2	16.3	12.4	-	-	26.4	3.0	23.4	19.4	15.5	11.5	-	-
	67	25.9	2.7	25.9	25.9	22.0	18.1	14.2	-	23.7	3.0	23.7	23.7	21.2	17.3	13.3	-
	62	25.0	2.7	25.0	25.0	24.8	20.9	17.0	13.0	23.1	3.0	23.1	23.1	23.0	19.1	15.1	11.2
	57	25.9	2.7	25.9	25.9	25.9	21.9	18.0	14.1	24.3	3.0	24.3	24.3	24.3	20.3	16.3	12.4
1125	72	29.0	2.7	26.1	21.6	17.2	12.8	-	-	26.6	3.0	25.3	20.8	16.4	11.9	-	-
	67	26.1	2.7	26.1	26.1	23.3	18.8	14.4	-	23.9	3.0	23.9	23.9	22.4	18.0	13.5	-
	62	25.2	2.7	25.2	25.2	25.1	20.7	16.2	11.8	23.2	3.0	23.2	23.2	23.2	18.7	14.2	9.8
	57	26.1	2.7	26.1	26.1	26.1	21.7	17.2	12.8	24.4	3.0	24.4	24.4	24.4	19.9	15.5	11.0
1250	72	29.2	2.7	28.0	23.0	18.1	13.2	-	-	26.7	3.0	26.7	22.3	17.3	12.3	-	-
	67	26.3	2.7	26.3	26.3	24.5	19.5	14.6	-	24.0	3.0	24.0	24.0	23.7	18.7	13.6	-
	62	25.4	2.7	25.4	25.4	25.4	20.5	15.5	10.6	23.4	3.0	23.4	23.4	23.4	18.4	13.4	8.4
	57	26.3	2.7	26.3	26.3	26.3	21.4	16.5	11.5	24.6	3.0	24.6	24.6	24.6	19.6	14.6	9.6

1. These capacities are Net Capacities.
2. These ratings include the compressor, condenser fan and supply air blower motors.

DNQ036 (3.0 Ton)

Air on Evaporator Coil		Temperature of Air on Condenser Coil															
CFM	WB (°F)	Net Capacity ¹ (MBh)	Total Input (kW) ²	Sensible Capacity (MBh)						Net Capacity ¹ (MBh)	Total Input (kW) ²	Sensible Capacity (MBh)					
				Return Dry Bulb (°F)								Return Dry Bulb (°F)					
				90	85	80	75	70	65			90	85	80	75	70	65
				75°F						85°F							
1050	77	47.5	1.5	23.1	18.9	14.7	-	-	-	44.6	2.4	23.4	19.0	14.7	-	-	-
	72	43.7	1.9	29.7	25.5	21.3	17.1	-	-	41.0	2.5	29.0	24.8	20.6	16.3	-	-
	67	39.9	2.3	36.3	32.1	27.9	23.6	19.4	-	37.5	2.5	34.7	30.6	26.4	22.1	17.9	-
	62	37.1	1.9	37.1	35.4	32.8	28.6	24.4	20.2	34.6	2.5	34.6	33.8	31.4	27.1	22.9	18.7
	57	37.4	2.0	37.4	36.6	34.4	30.2	26.0	21.8	35.2	2.5	35.2	34.8	32.9	28.7	24.4	20.2
1100	77	47.0	1.6	23.6	19.3	15.0	-	-	-	44.2	2.4	23.9	19.3	15.0	-	-	-
	72	43.2	2.0	30.4	26.0	21.7	17.3	-	-	40.7	2.5	29.6	25.2	20.9	16.5	-	-
	67	39.5	2.3	37.1	32.7	28.4	24.0	19.7	-	37.2	2.5	35.3	31.1	26.8	22.4	18.0	-
	62	36.7	2.0	36.7	35.6	33.4	29.1	24.7	20.4	34.3	2.5	34.3	33.8	31.8	27.4	23.1	18.7
	57	37.0	2.0	37.0	36.5	35.0	30.7	26.3	22.0	34.9	2.5	34.9	34.6	33.4	29.0	24.6	20.2
1200	77	46.1	1.7	24.7	20.2	15.5	-	-	-	43.5	2.4	25.1	20.1	15.4	-	-	-
	72	42.4	2.1	31.7	27.1	22.5	17.8	-	-	40.0	2.5	30.8	26.1	21.5	16.8	-	-
	67	38.7	2.4	38.7	34.0	29.4	24.7	20.1	-	36.6	2.5	36.6	32.2	27.5	22.9	18.2	-
	62	36.0	2.1	36.0	36.0	34.6	30.0	25.4	20.8	33.8	2.5	33.8	33.8	32.7	28.1	23.4	18.7
	57	36.3	2.1	36.3	36.3	36.3	31.6	27.0	22.4	34.3	2.5	34.3	34.3	34.3	29.7	25.0	20.3
1350	72	43.4	1.7	33.7	28.4	23.1	17.8	-	-	40.5	2.5	33.0	27.7	22.5	17.3	-	-
	67	39.6	2.1	39.6	35.5	30.2	25.0	19.7	-	37.0	2.5	37.0	34.1	28.9	23.6	18.4	-
	62	36.8	1.7	36.8	36.8	36.8	31.5	26.3	21.0	34.1	2.5	34.1	34.1	34.1	28.9	23.6	18.4
	57	37.1	1.8	37.1	37.1	37.1	31.9	26.6	21.3	34.7	2.5	34.7	34.7	34.7	29.5	24.2	19.0
				95°F						105°F							
1050	77	41.7	3.3	23.6	19.0	14.8	-	-	-	38.7	3.5	23.2	17.7	13.4	-	-	-
	72	38.4	3.0	28.3	24.1	19.8	15.6	-	-	35.5	3.4	27.1	22.9	18.7	14.4	-	-
	67	35.1	2.7	33.0	29.1	24.9	20.6	16.4	-	32.2	3.3	31.0	28.1	23.9	19.7	15.5	-
	62	32.1	3.1	32.1	32.1	29.9	25.6	21.4	17.1	29.9	3.5	29.9	29.7	27.6	23.4	19.1	14.9
	57	33.0	3.0	33.0	33.0	31.4	27.1	22.9	18.7	30.8	3.4	30.8	30.6	28.9	24.6	20.4	16.2
1100	77	41.4	3.3	24.2	19.3	14.9	-	-	-	38.5	3.5	24.2	18.0	13.6	-	-	-
	72	38.1	2.9	28.9	24.4	20.0	15.6	-	-	35.2	3.4	27.7	23.3	18.9	14.6	-	-
	67	34.9	2.6	33.5	29.6	25.2	20.8	16.3	-	32.0	3.2	31.2	28.6	24.3	19.9	15.5	-
	62	31.9	3.0	31.9	31.9	30.2	25.8	21.4	17.0	29.7	3.5	29.7	29.6	28.0	23.6	19.2	14.8
	57	32.8	3.0	32.8	32.8	31.7	27.3	22.9	18.5	30.5	3.4	30.5	30.4	29.3	24.9	20.5	16.2
1200	77	40.9	3.1	25.4	20.0	15.2	-	-	-	37.9	3.4	26.1	18.8	14.0	-	-	-
	72	37.7	2.8	29.9	25.2	20.5	15.7	-	-	34.8	3.3	28.9	24.2	19.5	14.8	-	-
	67	34.5	2.5	34.5	30.4	25.7	21.0	16.2	-	31.6	3.2	31.6	29.6	25.0	20.3	15.6	-
	62	31.5	2.9	31.5	31.5	30.8	26.1	21.4	16.7	29.3	3.4	29.3	29.3	28.8	24.1	19.4	14.7
	57	32.4	2.9	32.4	32.4	32.4	27.7	23.0	18.2	30.1	3.4	30.1	30.1	30.1	25.4	20.8	16.1
1350	72	37.5	3.2	32.3	27.1	21.9	16.7	-	-	34.7	3.5	31.0	25.8	20.6	15.4	-	-
	67	34.3	2.9	34.3	32.7	27.5	22.3	17.1	-	31.5	3.3	31.5	30.7	26.5	21.3	16.1	-
	62	31.4	3.3	31.4	31.4	31.4	26.2	21.0	15.8	29.3	3.6	29.3	29.3	29.3	24.1	18.9	13.7
	57	32.3	3.2	32.3	32.3	32.3	27.1	21.9	16.7	30.1	3.5	30.1	30.1	30.1	24.9	19.7	14.5

DNQ036 (3.0 Ton) (Continued)

Air on Evaporator Coil		Temperature of Air on Condenser Coil															
CFM	WB (°F)	Net Capacity ¹ (MBh)	Total Input (kW) ²	Sensible Capacity (MBh)						Net Capacity ¹ (MBh)	Total Input (kW) ²	Sensible Capacity (MBh)					
				Return Dry Bulb (°F)								Return Dry Bulb (°F)					
				90	85	80	75	70	65			90	85	80	75	70	65
				115°F						125°F							
1050	77	35.8	3.7	22.8	16.3	12.0	-	-	-	32.8	3.8	22.7	15.9	10.6	-	-	-
	72	32.6	3.8	25.9	21.7	17.5	13.3	-	-	29.7	4.1	24.6	20.5	16.3	12.1	-	-
	67	29.4	3.8	28.9	27.1	23.0	18.8	14.6	-	26.6	4.4	26.6	26.0	22.0	17.8	13.7	-
	62	27.8	3.9	27.8	27.3	25.3	21.1	16.9	12.7	25.6	4.3	25.6	24.9	23.0	18.8	14.6	10.4
	57	28.5	3.8	28.5	28.2	26.3	22.1	17.9	13.7	26.3	4.2	26.3	25.8	23.8	19.6	15.4	11.3
1100	77	35.5	3.7	24.2	16.7	12.2	-	-	-	32.5	3.9	24.3	16.8	10.9	-	-	-
	72	32.3	3.8	26.5	22.2	17.8	13.5	-	-	29.4	4.2	25.3	21.0	16.7	12.4	-	-
	67	29.2	3.9	28.9	27.6	23.4	19.1	14.7	-	26.4	4.5	26.4	26.0	22.5	18.2	13.9	-
	62	27.5	3.9	27.5	27.3	25.8	21.4	17.1	12.7	25.3	4.4	25.3	24.9	23.5	19.2	14.9	10.6
	57	28.3	3.8	28.3	28.1	26.8	22.5	18.1	13.8	26.0	4.3	26.0	25.7	24.4	20.1	15.7	11.4
1200	77	34.9	3.7	26.9	17.6	12.7	-	-	-	31.9	4.0	27.6	18.4	11.4	-	-	-
	72	31.8	3.8	27.8	23.1	18.5	13.8	-	-	28.9	4.3	26.7	22.1	17.5	12.9	-	-
	67	28.7	3.9	28.7	28.7	24.3	19.7	15.0	-	25.9	4.5	25.9	25.9	23.6	19.0	14.4	-
	62	27.1	3.9	27.1	27.1	26.7	22.1	17.4	12.8	24.9	4.4	24.9	24.9	24.7	20.1	15.5	10.8
	57	27.8	3.9	27.8	27.8	27.8	23.2	18.6	13.9	25.6	4.4	25.6	25.6	25.6	21.0	16.3	11.7
1350	72	31.9	3.7	29.7	24.5	19.4	14.2	-	-	29.0	4.0	28.5	23.3	18.1	12.9	-	-
	67	28.8	3.8	28.8	28.8	25.4	20.2	15.0	-	26.0	4.3	26.0	26.0	24.4	19.2	14.0	-
	62	27.1	3.9	27.1	27.1	27.1	21.9	16.8	11.6	25.0	4.2	25.0	25.0	25.0	19.8	14.6	9.4
	57	27.9	3.8	27.9	27.9	27.9	22.7	17.5	12.3	25.7	4.1	25.7	25.7	25.7	20.5	15.3	10.1

1. These capacities are Net Capacities.
2. These ratings include the compressor, condenser fan and supply air blower motors.

DNQ042 (3.0 Ton)

Air on Evaporator Coil		Temperature of Air on Condenser Coil															
CFM	WB (°F)	Net Capacity ¹ (MBh)	Total Input (kW) ²	Sensible Capacity (MBh)						Net Capacity ¹ (MBh)	Total Input (kW) ²	Sensible Capacity (MBh)					
				Return Dry Bulb (°F)								Return Dry Bulb (°F)					
				90	85	80	75	70	65			90	85	80	75	70	65
				75°F						85°F							
1350	77	56.0	2.7	30.9	26.2	20.5	-	-	-	51.4	2.8	29.7	23.9	18.1	-	-	-
	72	51.3	2.5	38.2	32.5	26.9	21.3	-	-	48.4	2.8	37.3	31.5	25.8	20.0	-	-
	67	46.5	2.3	45.5	38.9	33.3	27.6	22.0	-	45.5	2.8	44.9	39.2	33.4	27.6	21.9	-
	62	42.9	2.5	42.9	42.9	41.3	35.6	30.0	24.4	40.5	2.8	40.5	40.5	39.6	33.8	28.0	22.3
	57	42.7	2.5	42.7	42.7	41.5	35.9	30.2	24.6	40.5	2.8	40.5	40.5	39.7	34.0	28.2	22.4
1400	77	56.9	2.7	31.5	26.8	21.0	-	-	-	52.4	2.8	30.5	24.6	18.6	-	-	-
	72	52.1	2.5	39.1	33.3	27.5	21.7	-	-	49.5	2.8	38.4	32.4	26.5	20.5	-	-
	67	47.3	2.3	46.7	39.8	34.0	28.1	22.3	-	46.5	2.8	46.2	40.3	34.3	28.3	22.4	-
	62	43.6	2.5	43.6	43.6	42.1	36.3	30.5	24.7	41.4	2.8	41.4	41.4	40.6	34.7	28.7	22.8
	57	43.4	2.5	43.4	43.4	42.4	36.6	30.8	25.0	41.3	2.8	41.3	41.3	40.8	34.8	28.9	22.9
1500	72	50.6	2.6	41.0	34.8	28.5	22.3	-	-	47.8	2.8	40.0	33.7	27.4	21.1	-	-
	67	45.9	2.4	45.7	42.2	35.3	29.1	22.9	-	44.9	2.8	44.8	41.8	35.5	29.2	22.9	-
	62	42.3	2.5	42.3	42.3	41.6	35.4	29.2	23.0	39.9	2.8	39.9	39.9	39.6	33.3	27.0	20.7
	57	42.2	2.6	42.2	42.2	41.7	35.5	29.2	23.0	39.9	2.8	39.9	39.9	39.6	33.4	27.1	20.8
	1600	72	49.1	2.7	42.8	36.2	29.6	23.0	-	-	46.1	2.8	41.6	34.9	28.3	21.7	-
67		44.6	2.5	44.6	44.6	36.6	30.0	23.4	-	43.3	2.8	43.3	43.3	36.7	30.1	23.4	-
62		41.1	2.6	41.1	41.1	41.1	34.5	27.9	21.2	38.5	2.8	38.5	38.5	38.5	31.9	25.3	18.7
57		40.9	2.6	40.9	40.9	40.9	34.3	27.7	21.1	38.5	2.8	38.5	38.5	38.5	31.9	25.2	18.6
				95°F						105°F							
1350	77	46.7	2.9	28.5	21.6	15.7	-	-	-	45.3	3.5	30.9	21.8	15.9	-	-	-
	72	45.6	3.1	36.4	30.5	24.6	18.7	-	-	42.8	3.5	35.5	29.7	23.8	17.9	-	-
	67	44.5	3.3	44.3	39.4	33.5	27.6	21.7	-	40.2	3.6	40.1	37.5	31.7	25.8	20.0	-
	62	38.1	3.1	38.1	38.1	37.9	32.0	26.1	20.2	36.2	3.5	36.2	36.2	35.8	29.9	24.1	18.2
	57	38.2	3.1	38.2	38.2	37.9	32.0	26.1	20.2	36.1	3.5	36.1	36.1	35.7	29.8	23.9	18.0
1400	77	48.0	3.0	29.6	22.3	16.2	-	-	-	46.3	3.5	32.2	22.6	16.4	-	-	-
	72	46.8	3.1	37.6	31.5	25.4	19.3	-	-	43.7	3.6	36.7	30.6	24.5	18.5	-	-
	67	45.7	3.3	45.7	40.7	34.6	28.5	22.4	-	41.1	3.6	41.1	38.7	32.7	26.6	20.5	-
	62	39.2	3.1	39.2	39.2	39.2	33.1	27.0	20.9	37.0	3.5	37.0	37.0	36.9	30.8	24.8	18.7
	57	39.2	3.1	39.2	39.2	39.2	33.1	27.0	20.9	36.9	3.5	36.9	36.9	36.8	30.7	24.6	18.6
1500	72	44.9	3.1	38.9	32.6	26.2	19.8	-	-	42.5	3.5	38.2	31.9	25.5	19.2	-	-
	67	43.8	3.2	43.8	41.4	35.7	29.3	23.0	-	40.0	3.6	40.0	38.8	34.1	27.7	21.4	-
	62	37.6	3.0	37.6	37.6	37.6	31.2	24.8	18.5	36.0	3.5	36.0	36.0	36.0	29.6	23.3	17.0
	57	37.6	3.0	37.6	37.6	37.6	31.2	24.9	18.5	35.9	3.5	35.9	35.9	35.8	29.5	23.2	16.9
	1600	72	43.1	3.0	40.3	33.6	27.0	20.3	-	-	41.3	3.5	39.7	33.1	26.6	20.0	-
67		42.0	3.1	42.0	42.0	36.7	30.1	23.5	-	38.9	3.5	38.9	38.9	35.4	28.8	22.2	-
62		36.0	2.9	36.0	36.0	36.0	29.3	22.7	16.1	35.0	3.4	35.0	35.0	35.0	28.4	21.8	15.3
57		36.0	2.9	36.0	36.0	36.0	29.4	22.8	16.1	34.9	3.4	34.9	34.9	34.9	28.3	21.7	15.1

DNQ042 (3.0 Ton) (Continued)

Air on Evaporator Coil		Temperature of Air on Condenser Coil															
CFM	WB (°F)	Net Capacity ¹ (MBh)	Total Input (kW) ²	Sensible Capacity (MBh)						Net Capacity ¹ (MBh)	Total Input (kW) ²	Sensible Capacity (MBh)					
				Return Dry Bulb (°F)								Return Dry Bulb (°F)					
				90	85	80	75	70	65			90	85	80	75	70	65
				115°F						125°F							
1350	77	43.8	4.0	33.4	22.1	16.0	-	-	-	42.4	4.6	36.0	24.5	16.2	-	-	-
	72	39.9	4.0	34.7	28.8	23.0	17.1	-	-	37.0	4.4	33.8	28.0	22.1	16.3	-	-
	67	36.0	3.9	36.0	35.6	29.9	24.1	18.2	-	31.7	4.3	31.7	31.7	28.1	22.3	16.4	-
	62	34.2	3.9	34.2	34.2	33.7	27.9	22.0	16.1	32.3	4.4	32.3	32.3	31.7	25.8	20.0	14.1
	57	34.0	3.9	34.0	34.0	33.4	27.6	21.7	15.8	31.9	4.4	31.9	31.9	31.2	25.3	19.5	13.6
1400	77	44.6	4.0	34.9	22.8	16.5	-	-	-	42.9	4.5	37.6	25.5	16.6	-	-	-
	72	40.6	4.0	35.8	29.7	23.6	17.6	-	-	37.5	4.4	34.8	28.8	22.7	16.7	-	-
	67	36.6	3.9	36.6	36.6	30.8	24.7	18.7	-	32.0	4.2	32.0	32.0	28.8	22.8	16.8	-
	62	34.8	3.9	34.8	34.8	34.7	28.6	22.6	16.5	32.7	4.3	32.7	32.7	32.5	26.4	20.4	14.3
	57	34.6	3.9	34.6	34.6	34.4	28.3	22.3	16.2	32.2	4.3	32.2	32.2	32.0	25.9	19.9	13.8
1500	72	40.1	4.0	37.5	31.2	24.9	18.6	-	-	37.7	4.4	36.7	30.5	24.2	18.0	-	-
	67	36.2	3.9	36.2	36.2	32.4	26.1	19.8	-	32.3	4.3	32.3	32.3	30.8	24.5	18.3	-
	62	34.4	3.9	34.4	34.4	34.4	28.1	21.8	15.5	32.9	4.4	32.9	32.9	32.7	26.5	20.2	14.0
	57	34.1	3.9	34.1	34.1	34.1	27.8	21.5	15.2	32.4	4.4	32.4	32.4	32.3	26.0	19.8	13.5
	72	39.6	4.0	39.2	32.7	26.1	19.6	-	-	37.9	4.5	37.9	32.2	25.7	19.3	-	-
1600	67	35.7	3.9	35.7	35.7	34.0	27.5	21.0	-	32.6	4.3	32.6	32.6	32.6	26.2	19.8	-
	62	34.0	3.9	34.0	34.0	34.0	27.5	21.0	14.5	33.0	4.4	33.0	33.0	33.0	26.6	20.1	13.7
	57	33.7	3.9	33.7	33.7	33.7	27.2	20.7	14.2	32.6	4.4	32.6	32.6	32.6	26.1	19.7	13.2

1. These capacities are Net Capacities.
2. These ratings include the compressor, condenser fan and supply air blower motors.

DNQ048 (4.0 Ton)

Air on Evaporator Coil		Temperature of Air on Condenser Coil															
CFM	WB (°F)	Net Capacity ¹ (MBh)	Total Input (kW) ²	Sensible Capacity (MBh)						Net Capacity ¹ (MBh)	Total Input (kW) ²	Sensible Capacity (MBh)					
				Return Dry Bulb (°F)								Return Dry Bulb (°F)					
				90	85	80	75	70	65			90	85	80	75	70	65
				75°F						85°F							
1400	77	68.8	3.0	33.0	27.9	22.0	-	-	-	62.2	3.3	31.9	25.9	20.0	-	-	-
	72	64.1	2.9	42.2	36.3	30.3	24.4	-	-	57.7	3.3	40.3	34.3	28.4	22.5	-	-
	67	59.4	2.8	51.4	44.6	38.7	32.8	26.8	-	53.2	3.2	48.6	42.7	36.8	30.8	24.9	-
	62	52.4	2.8	52.4	50.7	47.6	41.7	35.7	29.8	48.2	3.2	48.2	47.3	44.4	38.4	32.5	26.6
	57	53.4	2.8	53.4	52.2	48.0	42.1	36.2	30.2	48.1	3.2	48.1	47.5	44.7	38.8	32.9	26.9
1500	77	67.4	3.0	33.7	28.8	22.7	-	-	-	62.5	3.3	33.3	27.0	20.8	-	-	-
	72	62.8	2.9	43.5	37.4	31.2	25.1	-	-	58.0	3.3	42.0	35.8	29.5	23.3	-	-
	67	58.2	2.8	53.4	46.0	39.8	33.7	27.5	-	53.4	3.2	50.7	44.5	38.3	32.0	25.8	-
	62	51.3	2.8	51.3	50.4	48.9	42.9	36.7	30.6	48.4	3.2	48.4	48.0	-	39.9	33.7	27.4
	57	52.3	2.8	52.3	51.7	49.4	43.3	37.1	31.0	48.4	3.2	48.4	48.0	46.6	40.3	34.1	27.8
1600	77	66.0	3.0	34.3	29.7	23.3	-	-	-	62.8	3.3	34.7	28.2	21.6	-	-	-
	72	61.5	2.9	44.9	38.5	32.1	25.8	-	-	58.2	3.3	43.8	37.2	30.7	24.1	-	-
	67	57.0	2.8	55.4	47.3	40.9	34.6	28.2	-	53.7	3.2	52.8	46.3	39.8	33.2	26.7	-
	62	50.1	2.8	50.1	50.1	50.1	44.0	37.7	31.3	48.6	3.2	48.6	48.6	48.0	41.4	34.9	28.3
	57	51.2	2.8	51.2	51.2	50.9	44.5	38.1	31.8	48.6	3.2	48.6	48.6	48.4	41.8	35.3	28.7
1700	72	61.8	2.9	48.0	41.2	34.4	27.6	-	-	58.8	3.3	46.5	39.7	32.8	25.9	-	-
	67	57.3	2.9	57.3	50.6	43.8	37.0	30.2	-	54.2	3.3	54.2	49.4	42.5	35.6	28.8	-
	62	50.3	2.8	50.3	50.3	50.3	43.5	36.7	29.9	49.0	3.2	49.0	49.0	49.0	42.2	35.3	28.4
	57	51.5	2.9	51.5	51.5	51.5	44.7	37.9	31.0	49.0	3.3	49.0	49.0	49.0	42.1	35.3	28.4
					95°F						105°F						
1400	77	55.6	3.7	30.7	23.9	18.0	-	-	-	51.7	4.3	31.3	23.2	17.2	-	-	-
	72	51.3	3.7	38.3	32.4	26.4	20.5	-	-	47.7	4.2	37.2	31.3	25.3	19.4	-	-
	67	47.0	3.7	45.9	40.8	34.9	28.9	23.0	-	43.6	4.1	43.1	39.4	33.4	27.5	21.6	-
	62	43.9	3.7	43.9	43.9	41.1	35.2	29.2	23.3	40.7	4.2	40.7	40.7	38.7	32.8	26.9	20.9
	57	42.8	3.7	42.8	42.8	41.5	35.5	29.6	23.6	40.1	4.2	40.1	40.1	38.9	32.9	27.0	21.1
1500	77	57.6	3.7	32.9	25.3	18.9	-	-	-	53.7	4.3	33.7	24.5	18.2	-	-	-
	72	53.1	3.7	40.5	34.2	27.8	21.5	-	-	49.5	4.2	39.3	33.0	26.7	20.4	-	-
	67	48.6	3.7	48.1	43.1	36.7	30.4	24.1	-	45.2	4.1	45.0	41.6	35.2	28.9	22.6	-
	62	45.5	3.7	45.5	45.5	43.3	37.0	30.7	24.3	42.2	4.2	42.2	42.2	40.8	34.5	28.2	21.9
	57	44.4	3.7	44.4	44.4	43.7	37.3	31.0	24.7	41.6	4.2	41.6	41.6	41.0	34.6	28.3	22.0
1600	77	59.6	3.7	35.0	26.6	19.9	-	-	-	55.6	4.2	36.1	25.8	19.1	-	-	-
	72	55.0	3.7	42.7	36.0	29.2	22.5	-	-	51.2	4.2	41.5	34.8	28.1	21.4	-	-
	67	50.3	3.7	50.3	45.3	38.6	31.9	25.2	-	46.9	4.1	46.9	43.8	37.0	30.3	23.6	-
	62	47.1	3.7	47.1	47.1	45.5	38.8	32.1	25.4	43.7	4.2	43.7	43.7	42.9	36.2	29.5	22.8
	57	45.9	3.6	45.9	45.9	45.9	39.2	32.5	25.7	43.1	4.2	43.1	43.1	43.1	36.4	29.6	22.9
1700	72	55.8	3.7	45.1	38.1	31.2	24.3	-	-	51.7	4.3	44.0	37.0	30.1	23.1	-	-
	67	51.0	3.7	51.0	48.1	41.2	34.3	27.3	-	47.3	4.2	47.3	45.8	39.7	32.7	25.8	-
	62	47.8	3.7	47.8	47.8	47.8	40.8	33.9	27.0	44.1	4.3	44.1	44.1	44.1	37.2	30.2	23.2
	57	46.6	3.7	46.6	46.6	46.6	39.6	32.7	25.8	43.5	4.3	43.5	43.5	43.5	36.5	29.6	22.6

DNQ048 (4.0 Ton) (Continued)

Air on Evaporator Coil		Temperature of Air on Condenser Coil															
CFM	WB (°F)	Net Capacity ¹ (MBh)	Total Input (kW) ²	Sensible Capacity (MBh)						Net Capacity ¹ (MBh)	Total Input (kW) ²	Sensible Capacity (MBh)					
				Return Dry Bulb (°F)								Return Dry Bulb (°F)					
				90	85	80	75	70	65			90	85	80	75	70	65
				115°F						125°F							
1400	77	47.8	4.9	31.8	22.4	16.5	-	-	-	43.9	5.5	32.9	22.0	15.8	-	-	-
	72	44.1	4.8	36.1	30.2	24.2	18.3	-	-	40.5	5.3	35.0	29.1	23.2	17.3	-	-
	67	40.3	4.6	40.3	37.9	32.0	26.1	20.2	-	37.0	5.1	37.0	36.5	30.6	24.7	18.8	-
	62	37.4	4.8	37.4	37.4	36.3	30.4	24.5	18.6	34.2	5.3	34.2	34.2	33.9	28.0	22.1	16.2
	57	37.4	4.8	37.4	37.4	36.3	30.4	24.4	18.5	34.7	5.3	34.7	34.7	33.7	27.8	21.9	16.0
1500	77	49.7	4.9	34.5	23.7	17.4	-	-	-	45.7	5.5	35.6	23.5	16.6	-	-	-
	72	45.8	4.7	38.2	31.9	25.6	19.3	-	-	42.1	5.2	37.0	30.7	24.4	18.2	-	-
	67	41.9	4.6	41.9	40.0	33.7	27.4	21.1	-	38.5	5.0	38.5	38.2	32.3	26.0	19.7	-
	62	38.9	4.7	38.9	38.9	38.3	32.0	25.7	19.4	35.5	5.3	35.5	35.5	35.4	29.5	23.2	16.9
	57	38.8	4.7	38.8	38.8	38.3	31.9	25.6	19.3	36.0	5.3	36.0	36.0	35.5	29.2	23.0	16.7
1600	77	51.5	4.8	37.2	25.0	18.3	-	-	-	47.4	5.4	38.3	24.9	17.5	-	-	-
	72	47.4	4.7	40.3	33.6	26.9	20.2	-	-	43.7	5.2	39.1	32.4	25.7	19.0	-	-
	67	43.4	4.5	43.4	42.2	35.5	28.8	22.1	-	39.9	4.9	39.9	39.9	33.9	27.3	20.6	-
	62	40.3	4.7	40.3	40.3	40.3	33.6	26.9	20.2	36.9	5.2	36.9	36.9	36.9	31.0	24.3	17.6
	57	40.2	4.7	40.2	40.2	40.2	33.5	26.8	20.1	37.4	5.2	37.4	37.4	37.4	30.7	24.0	17.3
1700	72	47.6	4.8	42.9	35.9	28.9	21.9	-	-	43.6	5.4	41.8	34.8	27.8	20.8	-	-
	67	43.6	4.7	43.6	43.6	38.2	31.2	24.2	-	39.9	5.2	39.9	39.9	36.7	29.7	22.6	-
	62	40.5	4.9	40.5	40.5	40.5	33.5	26.5	19.5	36.8	5.4	36.8	36.8	36.8	29.8	22.8	15.8
	57	40.4	4.8	40.4	40.4	40.4	33.4	26.4	19.5	37.3	5.4	37.3	37.3	37.3	30.3	23.3	16.3

1. These capacities are Net Capacities.
2. These ratings include the compressor, condenser fan and supply air blower motors.

DNQ060 (5.0 Ton)

Air on Evaporator Coil		Temperature of Air on Condenser Coil															
CFM	WB (°F)	Net Capacity ¹ (MBh)	Total Input (kW) ²	Sensible Capacity (MBh)						Net Capacity ¹ (MBh)	Total Input (kW) ²	Sensible Capacity (MBh)					
				Return Dry Bulb (°F)								Return Dry Bulb (°F)					
				90	85	80	75	70	65			90	85	80	75	70	65
				75°F						85°F							
1550	77	66.9	3.3	34.4	28.0	21.6	-	-	-	65.1	3.7	32.9	26.6	20.2	-	-	-
	72	61.6	3.2	43.2	36.8	30.4	24.0	-	-	60.4	3.7	42.3	36.0	29.6	23.3	-	-
	67	56.2	3.2	52.1	45.7	39.3	32.9	26.5	-	55.7	3.6	51.7	45.4	39.0	32.7	26.3	-
	62	51.9	3.2	51.9	51.9	47.1	40.7	34.3	27.8	51.4	3.6	51.4	51.4	45.6	39.4	32.9	26.6
	57	51.4	3.2	51.4	51.4	47.5	41.1	34.7	28.3	50.8	3.6	50.8	50.8	45.7	39.4	33.0	26.7
1650	77	71.0	3.3	36.0	30.4	23.8	-	-	-	67.6	3.7	35.5	28.8	22.1	-	-	-
	72	65.4	3.2	46.8	40.1	33.5	26.8	-	-	62.7	3.7	45.7	39.0	32.4	25.7	-	-
	67	59.7	3.2	57.6	49.8	43.2	36.5	29.8	-	57.9	3.6	55.9	49.3	42.6	36.0	29.3	-
	62	55.1	3.2	55.1	55.1	51.7	45.0	38.4	31.7	53.3	3.6	53.3	53.3	49.9	43.2	36.6	29.9
	57	54.5	3.2	54.5	54.5	52.2	45.6	38.9	32.2	52.7	3.6	52.7	52.7	50.0	43.3	36.7	30.0
1750	77	75.1	3.3	37.6	32.8	25.9	-	-	-	70.1	3.7	38.0	30.9	24.0	-	-	-
	72	69.1	3.2	50.4	43.4	36.5	29.5	-	-	65.0	3.7	49.0	42.1	35.1	28.2	-	-
	67	63.2	3.2	63.2	54.0	47.1	40.1	33.1	-	60.0	3.6	60.0	53.2	46.3	39.3	32.4	-
	62	58.3	3.2	58.3	58.3	56.4	49.4	42.5	35.5	55.3	3.6	55.3	55.3	54.1	47.2	40.2	33.3
	57	57.7	3.2	57.7	57.7	57.0	50.0	43.0	36.1	54.7	3.6	54.7	54.7	54.2	47.3	40.3	33.4
2000	72	69.3	3.2	51.8	44.2	36.7	29.1	-	-	65.0	3.7	50.3	42.6	34.8	27.0	-	-
	67	63.4	3.2	63.4	54.9	47.3	39.8	32.2	-	59.9	3.6	59.9	53.6	45.8	38.0	30.2	-
	62	58.5	3.2	58.5	58.5	56.7	49.1	41.6	34.0	55.2	3.6	55.2	55.2	53.6	45.8	38.0	30.2
	57	57.9	3.2	57.9	57.9	57.2	49.7	42.1	34.6	54.6	3.6	54.6	54.6	53.7	45.9	38.1	30.3
				95°F						105°F							
1550	77	63.3	4.1	31.4	25.1	18.8	-	-	-	59.3	4.4	36.6	29.5	23.1	-	-	-
	72	59.2	4.1	41.4	35.1	28.8	22.5	-	-	55.2	4.5	42.9	36.5	30.1	23.7	-	-
	67	55.2	4.1	51.4	45.1	38.8	32.4	26.1	-	51.1	4.6	49.1	43.5	37.1	30.7	24.3	-
	62	50.8	4.0	50.8	50.5	44.2	37.9	31.6	25.3	47.4	4.5	47.4	47.3	44.2	37.7	31.3	24.9
	57	50.2	4.0	50.2	50.2	43.9	37.6	31.3	25.0	47.3	4.4	47.3	47.3	44.1	37.7	31.3	24.9
1650	77	64.2	4.1	34.9	27.1	20.5	-	-	-	60.1	4.5	39.1	30.7	23.8	-	-	-
	72	60.1	4.1	44.5	37.9	31.3	24.7	-	-	55.9	4.6	45.0	38.1	31.2	24.4	-	-
	67	56.0	4.1	54.1	48.7	42.1	35.5	28.9	-	51.8	4.6	50.8	45.5	38.6	31.8	24.9	-
	62	51.5	4.0	51.5	51.4	48.1	41.4	34.8	28.2	48.1	4.5	48.1	48.0	46.4	39.5	32.6	25.8
	57	50.9	4.0	50.9	50.9	47.7	41.1	34.5	27.8	47.9	4.5	47.9	47.9	46.3	39.5	32.6	25.8
1750	77	65.1	4.1	38.4	29.0	22.1	-	-	-	60.9	4.6	41.5	31.9	24.6	-	-	-
	72	60.9	4.1	47.6	40.7	33.8	26.8	-	-	56.7	4.6	47.0	39.7	32.4	25.1	-	-
	67	56.8	4.1	56.8	52.4	45.4	38.5	31.6	-	52.5	4.7	52.5	47.5	40.2	32.9	25.6	-
	62	52.2	4.0	52.2	52.2	51.9	44.9	38.0	31.1	48.8	4.6	48.8	48.8	48.6	41.3	34.0	26.7
	57	51.6	4.0	51.6	51.6	51.5	44.6	37.6	30.7	48.6	4.5	48.6	48.6	48.5	41.2	33.9	26.6
2000	72	60.6	4.1	48.9	40.9	32.9	24.8	-	-	56.5	4.5	50.6	42.6	34.6	26.6	-	-
	67	56.5	4.0	56.5	52.2	44.2	36.2	28.2	-	52.3	4.6	52.3	50.2	42.6	34.6	26.6	-
	62	52.0	4.0	52.0	52.0	50.5	42.5	34.5	26.4	48.6	4.4	48.6	48.6	47.8	39.8	31.8	23.8
	57	51.4	4.0	51.4	51.4	50.1	42.1	34.1	26.1	48.4	4.4	48.4	48.4	47.8	39.8	31.8	23.7

DNQ060 (5.0 Ton) (Continued)

Air on Evaporator Coil		Temperature of Air on Condenser Coil															
CFM	WB (°F)	Net Capacity ¹ (MBh)	Total Input (kW) ²	Sensible Capacity (MBh)						Net Capacity ¹ (MBh)	Total Input (kW) ²	Sensible Capacity (MBh)					
				Return Dry Bulb (°F)								Return Dry Bulb (°F)					
				90	85	80	75	70	65			90	85	80	75	70	65
				115°F						125°F							
1550	77	55.3	4.8	41.8	33.9	27.3	-	-	-	51.3	5.1	49.0	38.2	31.6	-	-	-
	72	51.1	5.0	44.4	37.9	31.4	24.9	-	-	47.0	5.4	45.9	39.3	32.6	26.0	-	-
	67	46.9	5.1	46.9	41.9	35.4	28.9	22.4	-	42.8	5.7	42.8	40.3	33.7	27.1	20.5	-
	62	44.1	4.9	44.1	44.1	44.1	37.6	31.0	24.5	40.7	5.3	40.7	40.7	40.7	37.4	30.7	24.1
	57	44.4	4.8	44.4	44.4	44.4	37.8	31.3	24.8	41.4	5.1	41.4	41.4	41.4	38.0	31.4	24.7
1650	77	56.0	4.9	43.2	34.3	27.2	-	-	-	52.0	5.3	48.3	37.9	30.6	-	-	-
	72	51.8	5.1	45.4	38.3	31.2	24.1	-	-	47.7	5.5	45.9	38.5	31.2	23.8	-	-
	67	47.6	5.2	47.6	42.3	35.2	28.1	21.0	-	43.4	5.8	43.4	39.1	31.8	24.4	17.1	-
	62	44.7	5.0	44.7	44.7	44.7	37.6	30.5	23.4	41.3	5.5	41.3	41.3	41.3	35.6	28.3	21.0
	57	45.0	4.9	45.0	45.0	45.0	37.9	30.8	23.7	42.0	5.3	42.0	42.0	42.0	36.3	28.9	21.6
1750	77	56.8	5.0	44.6	34.8	27.1	-	-	-	52.7	5.4	47.7	37.6	29.6	-	-	-
	72	52.5	5.2	46.4	38.7	31.0	23.3	-	-	48.3	5.7	45.8	37.8	29.7	21.6	-	-
	67	48.2	5.3	48.2	42.7	35.0	27.3	19.6	-	43.9	6.0	43.9	37.9	29.8	21.7	13.7	-
	62	45.3	5.1	45.3	45.3	45.3	37.6	29.9	22.2	41.8	5.7	41.8	41.8	41.8	33.9	25.8	17.8
	57	45.6	5.0	45.6	45.6	45.6	37.9	30.2	22.5	42.6	5.4	42.6	42.6	42.6	34.6	26.5	18.4
2000	72	52.4	4.9	52.4	44.4	36.3	28.3	-	-	48.3	5.3	48.3	46.1	38.1	30.1	-	-
	67	48.1	5.1	48.1	48.1	41.0	33.0	25.0	-	44.0	5.6	44.0	44.0	39.4	31.4	23.3	-
	62	45.2	4.9	45.2	45.2	45.2	37.2	29.2	21.1	41.8	5.3	41.8	41.8	41.8	34.5	26.5	18.5
	57	45.5	4.7	45.5	45.5	45.5	37.5	29.5	21.4	42.6	5.1	42.6	42.6	42.6	35.2	27.1	19.1

1. These capacities are Net Capacities.
2. These ratings include the compressor, condenser fan and supply air blower motors.

Airflow Performance

Side Duct Application

DNX/DNQ024-060

Size (Tons)	Model	Mode		Thermostat Input	Speed Tap	CFM	External Static Pressure (Inch Water Gauge)										
							0.2	0.3	0.4	0.5	0.6	0.7	0.8	0.9	1.0		
							Watts	Watts	Watts	Watts	Watts	Watts	Watts	Watts	Watts		
024 (2.0)	DNQ	Cool	High	Y1	COOL-A	800	177	204	232	261	290	320	350	382	414		
				Y1	COOL-B	600	100	122	145	169	194	221	249	279	310		
				Y1	COOL-C	700	134	159	184	211	238	265	293	323	352		
				Y1	COOL-D	900	229	258	288	319	351	385	420	457	494		
		Heat	N036	W1	HEAT-A	670	123	147	172	197	224	251	-	-	-	-	
				W1	HEAT-B	730	146	172	198	225	252	280	-	-	-		
				W1	HEAT-C	790	173	199	227	255	284	314	-	-	-		
				W1	HEAT-D	850	202	230	259	289	319	351	-	-	-		
			N056	W1	HEAT-A	940	253	281	312	344	378	-	-	-	-		
				W1	HEAT-B	975	274	303	334	368	403	-	-	-	-		
				W1	HEAT-C	1000	290	319	351	385	422	-	-	-	-		
				W1	HEAT-D	1050	324	353	386	422	461	-	-	-	-		
			D056	W1	HEAT-A	670	123	147	172	197	224	-	-	-	-		
					HEAT-B	690	130	155	180	206	233	-	-	-	-		
					HEAT-C	710	138	163	189	215	242	-	-	-	-		
					HEAT-D	750	155	181	207	235	262	-	-	-	-		
		W1+W2		HEAT-A	940	253	281	312	344	378	-	-	-	-			
				HEAT-B	970	271	300	331	364	400	-	-	-	-			
				HEAT-C	1000	290	319	351	385	422	-	-	-	-			
				HEAT-D	1050	324	353	386	422	461	-	-	-	-			
		024 (2.0)	DNX	Cool	Low	Y1	COOL-A	600	100	122	145	169	194	221	249	279	310
						Y1	COOL-B	450	65	81	100	122	147	176	208	243	281
						Y1	COOL-C	530	81	100	121	145	170	197	226	258	291
						Y1	COOL-D	680	127	151	176	202	228	256	284	313	342
					High	Y1+Y2	COOL-A	800	177	204	232	261	290	320	350	382	414
						Y1+Y2	COOL-B	600	100	122	145	169	194	221	249	279	310
						Y1+Y2	COOL-C	700	134	159	184	211	238	265	293	323	352
						Y1+Y2	COOL-D	900	229	258	288	319	351	385	420	457	494
Heat	N036			W1	HEAT-A	670	123	147	172	197	224	251	-	-	-		
				W1	HEAT-B	730	146	172	198	225	252	280	-	-	-		
				W1	HEAT-C	790	173	199	227	255	284	314	-	-	-		
				W1	HEAT-D	850	202	230	259	289	319	351	-	-	-		
	N056			W1	HEAT-A	940	253	281	312	344	378	-	-	-	-		
				W1	HEAT-B	975	274	303	334	368	403	-	-	-	-		
				W1	HEAT-C	1000	290	319	351	385	422	-	-	-	-		
				W1	HEAT-D	1050	324	353	386	422	461	-	-	-	-		
	D056			W1	HEAT-A	670	123	147	172	197	224	-	-	-	-		
					HEAT-B	690	130	155	180	206	233	-	-	-	-		
					HEAT-C	710	138	163	189	215	242	-	-	-	-		
					HEAT-D	750	155	181	207	235	262	-	-	-	-		
W1+W2				HEAT-A	940	253	281	312	344	378	-	-	-	-			
				HEAT-B	970	271	300	331	364	400	-	-	-	-			
				HEAT-C	1000	290	319	351	385	422	-	-	-	-			
				HEAT-D	1050	324	353	386	422	461	-	-	-	-			
030 (2.5)	DNQ			Cool	High	Y1	COOL-A	900	222	254	291	323	340	381	431	462	516
						Y1	COOL-B	1000	271	306	360	397	433	469	508	554	571
						Y1	COOL-C	1125	367	411	445	500	533	588	625	647	665
						Y1	COOL-D	1250	472	522	587	628	660	686	701	720	736
		Heat	N036	W1	HEAT-A	670	121	152	180	205	228	257	-	-	-		
				W1	HEAT-B	730	143	180	204	225	260	286	-	-	-		
				W1	HEAT-C	790	172	205	237	267	296	329	-	-	-		
				W1	HEAT-D	850	195	235	263	310	324	366	-	-	-		
			N056	W1	HEAT-A	1050	297	341	385	427	469	-	-	-	-		
				W1	HEAT-B	1135	379	417	455	496	536	-	-	-	-		
				W1	HEAT-C	1220	448	493	537	586	635	-	-	-	-		
				W1	HEAT-D	1300	514	562	610	655	700	-	-	-	-		
			D056	W1	HEAT-A	680	130	161	189	214	237	-	-	-	-		
					HEAT-B	735	150	185	212	229	269	-	-	-	-		
					HEAT-C	790	172	205	237	267	296	-	-	-	-		
					HEAT-D	840	204	244	272	319	333	-	-	-	-		
		W1+W2		HEAT-A	1050	297	341	385	427	469	-	-	-	-			
				HEAT-B	1135	379	417	455	496	536	-	-	-	-			
				HEAT-C	1220	448	493	537	586	635	-	-	-	-			
				HEAT-D	1300	514	562	610	655	700	-	-	-	-			

DNX/DNQ024-060 (Continued)

Size (Tons)	Model	Mode	Thermostat Input	Speed Tap	CFM	External Static Pressure (Inch Water Gauge)										
						0.2	0.3	0.4	0.5	0.6	0.7	0.8	0.9	1.0		
						Watts	Watts	Watts	Watts	Watts	Watts	Watts	Watts	Watts		
036 (3.0)	DNQ	Cool	High	Y1	COOL-A	1100	363	410	459	509	559	611	664	719	773	
				Y1	COOL-B	1050	328	375	424	474	524	576	629	684	738	
				Y1	COOL-C	1200	439	489	541	595	652	710	771	835	900	
				Y1	COOL-D	1350	576	626	680	737	798	863	932	1005	-	
		Heat	N036	W1	HEAT-A	670	162	194	227	258	289	320	-	-	-	-
				W1	HEAT-B	730	177	213	248	283	318	352	-	-	-	
				W1	HEAT-C	790	196	235	274	312	350	388	-	-	-	
				W1	HEAT-D	850	220	261	303	344	385	426	-	-	-	
			N056	W1	HEAT-A	1050	328	375	424	474	524	-	-	-	-	
				W1	HEAT-B	1135	388	437	488	540	594	-	-	-	-	
				W1	HEAT-C	1220	456	506	558	613	670	-	-	-	-	
				W1	HEAT-D	1300	528	578	631	687	747	-	-	-	-	
		Heat	D056	W1	HEAT-A	680	164	197	230	262	294	-	-	-	-	
				W1	HEAT-B	735	178	215	250	286	321	-	-	-	-	
				W1	HEAT-C	790	196	235	274	312	350	-	-	-	-	
				W1	HEAT-D	840	216	257	297	338	379	-	-	-	-	
			N072	W1+W2	HEAT-A	1050	328	375	424	474	524	-	-	-	-	
				W1+W2	HEAT-B	1140	392	441	491	544	598	-	-	-	-	
				W1+W2	HEAT-C	1220	456	506	558	613	670	-	-	-	-	
				W1+W2	HEAT-D	1300	528	578	631	687	747	-	-	-	-	
		Heat	D072	W1	HEAT-A	1200	439	489	541	595	-	-	-	-		
				W1	HEAT-B	1300	528	578	631	687	-	-	-	-		
				W1	HEAT-C	1400	628	677	731	789	-	-	-	-		
				W1	HEAT-D	1475	710	759	812	871	-	-	-	-		
			N072	W1	HEAT-A	790	196	235	274	312	-	-	-	-		
				W1	HEAT-B	855	222	264	305	347	-	-	-	-		
				W1	HEAT-C	920	252	296	341	385	-	-	-	-		
				W1	HEAT-D	975	282	328	374	421	-	-	-	-		
D072	W1+W2	HEAT-A	1200	439	489	541	595	-	-	-	-					
	W1+W2	HEAT-B	1300	528	578	631	687	-	-	-	-					
	W1+W2	HEAT-C	1400	628	677	731	789	-	-	-	-					
	W1+W2	HEAT-D	1480	716	764	818	877	-	-	-	-					
036 (3.0)	DNX	Cool	Low	Y1	COOL-A	900	198	233	272	313	358	406	458	512	569	
				Y1	COOL-B	760	166	190	222	262	310	366	431	503	584	
				Y1	COOL-C	830	180	210	245	286	332	384	441	503	571	
				Y1	COOL-D	970	221	260	302	344	388	434	481	530	579	
			High	Y1+Y2	COOL-A	1250	361	408	454	501	548	594	640	687	733	
				Y1+Y2	COOL-B	1050	253	296	340	384	428	472	516	561	605	
				Y1+Y2	COOL-C	1150	302	348	394	439	484	528	571	615	657	
				Y1+Y2	COOL-D	1350	429	475	522	570	620	671	723	777	831	
		Heat	N065	W1	HEAT-A	1200	330	377	423	469	515	560	-	-	-	
				W1	HEAT-B	1300	394	440	487	535	583	631	-	-	-	
				W1	HEAT-C	1400	467	511	558	607	659	713	-	-	-	
				W1	HEAT-D	1500	550	590	635	686	743	804	-	-	-	
			N090	W1	HEAT-A	1150	302	348	394	439	484	528	-	-	-	
				W1	HEAT-B	1225	345	392	439	485	531	577	-	-	-	
				W1	HEAT-C	1275	377	424	471	518	565	612	-	-	-	
				W1	HEAT-D	1350	429	475	522	570	620	671	-	-	-	
			D090	W1	HEAT-A	740	163	185	216	255	304	362	-	-	-	
				W1	HEAT-B	785	170	196	230	270	317	372	-	-	-	
				W1	HEAT-C	825	178	208	243	284	330	382	-	-	-	
				W1	HEAT-D	870	189	223	260	301	347	396	-	-	-	
				W1+W2	HEAT-A	1150	302	348	394	439	484	528	-	-	-	
				W1+W2	HEAT-B	1220	342	389	436	482	528	573	-	-	-	
				W1+W2	HEAT-C	1280	380	427	474	521	568	616	-	-	-	
				W1+W2	HEAT-D	1350	429	475	522	570	620	671	-	-	-	

DNX/DNQ024-060 (Continued)

Size (Tons)	Model	Mode	Thermostat Input	Speed Tap	CFM	External Static Pressure (Inch Water Gauge)											
						0.2	0.3	0.4	0.5	0.6	0.7	0.8	0.9	1.0			
						Watts	Watts	Watts	Watts	Watts	Watts	Watts	Watts	Watts			
042 (3.5)	DNQ	Cool	High	Y1	COOL-A	1400	466	513	561	611	663	715	770	826	882		
				Y1	COOL-B	1350	430	476	523	571	621	672	718	766	815		
				Y1	COOL-C	1500	544	596	648	702	758	815	867	921	975		
				Y1	COOL-D	1600	630	687	745	804	864	926	988	1052	1116		
			N065	W1	HEAT-A	1200	330	373	416	461	507	554	-	-	-		
				W1	HEAT-B	1300	394	439	484	531	579	629	-	-	-		
				W1	HEAT-C	1400	466	513	561	611	663	715	-	-	-		
				W1	HEAT-D	1500	544	596	648	702	758	815	-	-	-		
			N090	W1	HEAT-A	1325	412	456	503	550	599	649	-	-	-		
				W1	HEAT-B	1400	466	513	561	611	663	715	-	-	-		
				W1	HEAT-C	1500	544	596	648	702	758	815	-	-	-		
				W1	HEAT-D	1600	630	687	745	804	864	926	-	-	-		
		Heat	D090	W1	HEAT-A	870	168	215	261	306	350	393	-	-	-		
				W1	HEAT-B	920	188	233	278	322	366	409	-	-	-		
				W1	HEAT-C	985	216	260	303	347	391	434	-	-	-		
				W1	HEAT-D	1050	247	290	333	376	420	464	-	-	-		
			W1+W2	W1+W2	HEAT-A	1330	415	460	506	554	603	653	-	-	-		
				W1+W2	HEAT-B	1400	466	513	561	611	663	715	-	-	-		
				W1+W2	HEAT-C	1500	544	596	648	702	758	815	-	-	-		
				W1+W2	HEAT-D	1600	630	687	745	804	864	926	-	-	-		
		048 (4.0)	DNQ	Cool	High	Y1	COOL-A	1500	544	596	648	702	758	815	867	921	975
						Y1	COOL-B	1400	466	513	561	611	663	715	770	826	882
						Y1	COOL-C	1600	630	687	745	804	864	926	988	1052	1116
						Y1	COOL-D	1700	723	787	851	916	982	1049	1116	1185	1247
N065	W1				HEAT-A	1200	330	373	416	461	507	554	-	-	-		
	W1				HEAT-B	1300	394	439	484	531	579	629	-	-	-		
	W1				HEAT-C	1400	466	513	561	611	663	715	-	-	-		
	W1				HEAT-D	1500	544	596	648	702	758	815	-	-	-		
N090	W1				HEAT-A	1325	412	456	503	550	599	649	-	-	-		
	W1				HEAT-B	1400	466	513	561	611	663	715	-	-	-		
	W1				HEAT-C	1500	544	596	648	702	758	815	-	-	-		
	W1				HEAT-D	1600	630	687	745	804	864	926	-	-	-		
Heat	D090			W1	HEAT-A	870	168	215	261	306	350	393	-	-	-		
				W1	HEAT-B	920	188	233	278	322	366	409	-	-	-		
				W1	HEAT-C	985	216	260	303	347	391	434	-	-	-		
				W1	HEAT-D	1050	247	290	333	376	420	464	-	-	-		
	W1+W2			W1+W2	HEAT-A	1330	415	460	506	554	603	653	-	-	-		
				W1+W2	HEAT-B	1400	466	513	561	611	663	715	-	-	-		
				W1+W2	HEAT-C	1500	544	596	648	702	758	815	-	-	-		
				W1+W2	HEAT-D	1600	630	687	745	804	864	926	-	-	-		
N110	W1			HEAT-A	1450	504	553	604	656	-	-	-	-	-			
	W1			HEAT-B	1500	544	596	648	702	-	-	-	-	-			
	W1			HEAT-C	1600	630	687	745	804	-	-	-	-	-			
	W1			HEAT-D	1700	723	787	851	916	-	-	-	-	-			
D110	W1	HEAT-A	940	196	241	285	329	-	-	-	-	-					
	W1	HEAT-B	970	209	253	297	341	-	-	-	-	-					
	W1	HEAT-C	1050	247	290	333	376	-	-	-	-	-					
	W1	HEAT-D	1100	273	315	358	402	-	-	-	-	-					
W1+W2	W1+W2	HEAT-A	1450	504	553	604	656	-	-	-	-	-					
	W1+W2	HEAT-B	1500	544	596	648	702	-	-	-	-	-					
	W1+W2	HEAT-C	1600	630	687	745	804	-	-	-	-	-					
	W1+W2	HEAT-D	1700	723	787	851	916	-	-	-	-	-					

DNX/DNQ024-060 (Continued)

Size (Tons)	Model	Mode	Thermostat Input	Speed Tap	CFM	External Static Pressure (Inch Water Gauge)									
						0.2	0.3	0.4	0.5	0.6	0.7	0.8	0.9	1.0	
						Watts	Watts	Watts	Watts	Watts	Watts	Watts	Watts	Watts	
048 (4.0)	DNX	Cool	Low	Y1	COOL-A	1030	237	280	323	367	411	455	499	543	588
				Y1	COOL-B	930	192	237	282	326	369	413	455	497	539
				Y1	COOL-C	1070	257	300	343	386	430	475	520	565	611
				Y1	COOL-D	1130	289	332	375	419	463	509	555	602	649
			High	Y1+Y2	COOL-A	1550	586	640	696	752	810	869	929	991	1053
				Y1+Y2	COOL-B	1400	466	513	561	611	663	715	770	826	882
				Y1+Y2	COOL-C	1600	630	687	745	804	864	926	988	1052	1116
				Y1+Y2	COOL-D	1700	723	787	851	916	982	1049	1116	1185	-
		Heat	N065	W1	HEAT-A	1200	330	373	416	461	507	554	-	-	-
				W1	HEAT-B	1300	394	439	484	531	579	629	-	-	-
				W1	HEAT-C	1400	466	513	561	611	663	715	-	-	-
				W1	HEAT-D	1500	544	596	648	702	758	815	-	-	-
			N090	W1	HEAT-A	1325	412	456	503	550	599	649	-	-	-
				W1	HEAT-B	1400	466	513	561	611	663	715	-	-	-
				W1	HEAT-C	1500	544	596	648	702	758	815	-	-	-
				W1	HEAT-D	1600	630	687	745	804	864	926	-	-	-
			D090	W1	HEAT-A	870	168	215	261	306	350	393	-	-	-
				W1	HEAT-B	920	188	233	278	322	366	409	-	-	-
				W1	HEAT-C	985	216	260	303	347	391	434	-	-	-
				W1	HEAT-D	1050	247	290	333	376	420	464	-	-	-
				W1+W2	HEAT-A	1330	415	460	506	554	603	653	-	-	-
				W1+W2	HEAT-B	1400	466	513	561	611	663	715	-	-	-
				W1+W2	HEAT-C	1500	544	596	648	702	758	815	-	-	-
				W1+W2	HEAT-D	1600	630	687	745	804	864	926	-	-	-
			N110	W1	HEAT-A	1450	504	553	604	656	-	-	-	-	-
				W1	HEAT-B	1500	544	596	648	702	-	-	-	-	-
				W1	HEAT-C	1600	630	687	745	804	-	-	-	-	-
				W1	HEAT-D	1700	723	787	851	916	-	-	-	-	-
D110	W1	HEAT-A	940	196	241	285	329	-	-	-	-	-			
	W1	HEAT-B	970	209	253	297	341	-	-	-	-	-			
	W1	HEAT-C	1050	247	290	333	376	-	-	-	-	-			
	W1	HEAT-D	1100	273	315	358	402	-	-	-	-	-			
	W1+W2	HEAT-A	1450	504	553	604	656	-	-	-	-	-			
	W1+W2	HEAT-B	1500	544	596	648	702	-	-	-	-	-			
	W1+W2	HEAT-C	1600	630	687	745	804	-	-	-	-	-			
	W1+W2	HEAT-D	1700	723	787	851	916	-	-	-	-	-			
060 (5.0)	DNQ	Cool	High	Y1	COOL-A	1550	438	480	522	609	696	736	803	866	930
				Y1	COOL-B	1650	510	554	598	690	782	826	896	963	1031
				Y1	COOL-C	1750	589	635	682	778	873	924	995	1066	1137
				Y1	COOL-D	2000	822	875	927	1027	1128	1198	-	-	-
		Heat	N065	W1	HEAT-A	1200	251	285	319	382	445	475	-	-	-
				W1	HEAT-B	1300	295	331	367	438	509	541	-	-	-
				W1	HEAT-C	1400	346	385	423	501	579	613	-	-	-
				W1	HEAT-D	1500	405	446	487	572	656	693	-	-	-
			N090	W1	HEAT-A	1325	307	344	381	453	526	558	-	-	-
				W1	HEAT-B	1400	346	385	423	501	579	613	-	-	-
				W1	HEAT-C	1500	405	446	487	572	656	693	-	-	-
				W1	HEAT-D	1600	473	516	559	649	738	780	-	-	-
			D090	W1	HEAT-A	870	165	191	218	246	275	307	-	-	-
				W1	HEAT-B	920	172	200	228	262	296	328	-	-	-
				W1	HEAT-C	985	185	214	243	285	326	357	-	-	-
				W1	HEAT-D	1050	201	232	263	311	359	389	-	-	-
				W1+W2	HEAT-A	1330	309	346	383	456	530	562	-	-	-
				W1+W2	HEAT-B	1400	346	385	423	501	579	613	-	-	-
				W1+W2	HEAT-C	1500	405	446	487	572	656	693	-	-	-
				W1+W2	HEAT-D	1600	473	516	559	649	738	780	-	-	-
			N110	W1	HEAT-A	1450	375	414	454	536	617	652	-	-	-
				W1	HEAT-B	1500	405	446	487	572	656	693	-	-	-
				W1	HEAT-C	1600	473	516	559	649	738	780	-	-	-
				W1	HEAT-D	1700	548	594	639	733	827	874	-	-	-
		D110	W1	HEAT-A	940	176	204	232	269	305	336	-	-	-	
			W1	HEAT-B	985	185	214	243	285	326	357	-	-	-	
			W1	HEAT-C	1035	197	227	258	305	351	381	-	-	-	
			W1	HEAT-D	1100	216	248	279	333	386	416	-	-	-	
W1+W2	HEAT-A		1450	375	414	454	536	617	652	-	-	-			
W1+W2	HEAT-B		1500	405	446	487	572	656	693	-	-	-			
W1+W2	HEAT-C		1600	473	516	559	649	738	780	-	-	-			
W1+W2	HEAT-D		1700	548	594	639	733	827	874	-	-	-			

DNZ024-060

Size (Tons)	Model	Unit Speed	External Static Pressure (Inch Water Gauge)														
			0.2			0.4			0.6			0.8			1.0		
			SCFM	W	RPM	SCFM	W	RPM	SCFM	W	RPM	SCFM	W	RPM	SCFM	W	RPM
024 (2.0)	DNZ	Low (1)	719	115	752	617	130	858	-	-	-	-	-	-	-	-	-
		Low/Medium (2)	781	137	789	691	155	891	-	-	-	-	-	-	-	-	-
		Medium (3)	902	187	858	824	207	949	734	223	1037	622	230	1116	-	-	-
		Medium/High (4)	-	-	-	937	258	998	845	270	1075	722	271	1146	-	-	-
		High (5)	-	-	-	-	-	-	933	316	1104	796	307	1162	-	-	-
030 (2.5)	DNZ	Low (1)	827	163	825	759	187	919	-	-	-	-	-	-	-	-	-
		Low/Medium (2)	988	251	914	916	269	992	831	282	1067	-	-	-	-	-	-
		Medium (3)	1113	322	984	1035	333	1047	941	337	1108	818	329	1162	-	-	-
		Medium/High (4)	1233	394	1050	1145	394	1099	1040	388	1145	901	367	1184	-	-	-
		High (5)	-	-	-	-	-	-	1078	425	1164	867	353	1173	-	-	-
036 (3.0)	DNZ	Low (1)	1032	236	789	921	258	853	-	-	-	-	-	-	-	-	-
		Low/Medium (2)	1185	317	859	1089	347	924	985	373	991	-	-	-	-	-	-
		Medium (3)	1304	395	913	1214	424	978	1114	448	1040	994	462	1098	-	-	-
		Medium/High (4)	1445	515	976	1357	532	1041	1252	542	1097	1117	537	1140	-	-	-
		High (5)	-	-	-	1498	708	1108	1363	665	1157	1179	599	1178	-	-	-
042 (3.5)	DNZ	Low (1)	1114	176	642	-	-	-	-	-	-	-	-	-	-	-	-
		Low/Medium (2)	1223	230	679	1056	264	773	-	-	-	-	-	-	-	-	-
		Medium (3)	1641	404	751	1418	460	872	1288	492	942	1187	518	997	1101	540	1044
		Medium/High (4)	-	-	-	1535	547	904	1398	582	976	1292	606	1030	1203	624	1074
		High (5)	-	-	-	1665	664	940	1514	701	1015	1399	720	1067	1304	729	1106
048 (4.0)	DNZ	Low (1)	1378	310	749	1209	343	840	-	-	-	-	-	-	-	-	-
		Low/Medium (2)	1414	331	763	1253	366	851	-	-	-	-	-	-	-	-	-
		Medium (3)	1713	544	872	1604	587	940	1484	624	1005	1343	653	1067	-	-	-
		Medium/High (4)	1882	703	931	1786	740	987	1671	769	1044	1522	783	1099	1231	717	1142
		High (5)	-	-	-	1972	946	1037	1851	949	1078	1689	927	1118	1306	759	1142
060 (5.0)	DNZ	Low (1)	1556	416	802	-	-	-	-	-	-	-	-	-	-	-	-
		Low/Medium (2)	1648	489	843	1522	529	917	-	-	-	-	-	-	-	-	-
		Medium (3)	1767	595	892	1664	633	954	1546	668	1015	-	-	-	-	-	-
		Medium/High (4)	1913	739	946	1819	769	996	1702	791	1049	1550	800	1102	-	-	-
		High (5)	2103	952	1007	1990	957	1047	1855	948	1086	1674	912	1122	-	-	-

Bottom Duct Application

DNX/DNQ024-060

Size (Tons)	Model	Mode		Thermostat Input	Speed Tap	CFM	External Static Pressure (Inch Water Gauge)										
							0.2	0.3	0.4	0.5	0.6	0.7	0.8	0.9	1.0		
							Watts	Watts	Watts	Watts	Watts	Watts	Watts	Watts	Watts		
024 (2.0)	DNQ	Cool	High	Y1	COOL-A	800	177	204	232	261	290	320	350	382	414		
				Y1	COOL-B	600	100	122	145	169	194	221	249	279	310		
				Y1	COOL-C	700	134	159	184	211	238	265	293	323	352		
				Y1	COOL-D	900	229	258	288	319	351	385	420	457	494		
		Heat	N036	W1	HEAT-A	670	123	147	172	197	224	251	-	-	-	-	
				W1	HEAT-B	730	146	172	198	225	252	280	-	-	-		
				W1	HEAT-C	790	173	199	227	255	284	314	-	-	-		
				W1	HEAT-D	850	202	230	259	289	319	351	-	-	-		
			N056	W1	HEAT-A	940	253	281	312	344	378	-	-	-	-		
				W1	HEAT-B	975	274	303	334	368	403	-	-	-	-		
				W1	HEAT-C	1000	290	319	351	385	422	-	-	-	-		
				W1	HEAT-D	1050	324	353	386	422	461	-	-	-	-		
			D056	W1	HEAT-A	670	123	147	172	197	224	-	-	-	-		
				W1	HEAT-B	690	130	155	180	206	233	-	-	-	-		
				W1	HEAT-C	710	138	163	189	215	242	-	-	-	-		
				W1	HEAT-D	750	155	181	207	235	262	-	-	-	-		
		W1+W2		HEAT-A	940	253	281	312	344	378	-	-	-	-			
		W1+W2		HEAT-B	970	271	300	331	364	400	-	-	-	-			
		W1+W2		HEAT-C	1000	290	319	351	385	422	-	-	-	-			
		W1+W2		HEAT-D	1050	324	353	386	422	461	-	-	-	-			
		024 (2.0)	DNX	Cool	Low	Y1	COOL-A	600	100	122	145	169	194	221	249	279	310
						Y1	COOL-B	450	65	81	100	122	147	176	208	243	281
						Y1	COOL-C	530	81	100	121	145	170	197	226	258	291
						Y1	COOL-D	680	127	151	176	202	228	256	284	313	342
					High	Y1+Y2	COOL-A	800	177	204	232	261	290	320	350	382	414
						Y1+Y2	COOL-B	600	100	122	145	169	194	221	249	279	310
						Y1+Y2	COOL-C	700	134	159	184	211	238	265	293	323	352
						Y1+Y2	COOL-D	900	229	258	288	319	351	385	420	457	494
Heat	N036			W1	HEAT-A	670	123	147	172	197	224	251	-	-	-		
				W1	HEAT-B	730	146	172	198	225	252	280	-	-	-		
				W1	HEAT-C	790	173	199	227	255	284	314	-	-	-		
				W1	HEAT-D	850	202	230	259	289	319	351	-	-	-		
	N056			W1	HEAT-A	940	253	281	312	344	378	-	-	-	-		
				W1	HEAT-B	975	274	303	334	368	403	-	-	-	-		
				W1	HEAT-C	1000	290	319	351	385	422	-	-	-	-		
				W1	HEAT-D	1050	324	353	386	422	461	-	-	-	-		
	D056			W1	HEAT-A	670	123	147	172	197	224	-	-	-	-		
				W1	HEAT-B	690	130	155	180	206	233	-	-	-	-		
				W1	HEAT-C	710	138	163	189	215	242	-	-	-	-		
				W1	HEAT-D	750	155	181	207	235	262	-	-	-	-		
W1+W2				HEAT-A	940	253	281	312	344	378	-	-	-	-			
W1+W2				HEAT-B	970	271	300	331	364	400	-	-	-	-			
W1+W2				HEAT-C	1000	290	319	351	385	422	-	-	-	-			
W1+W2				HEAT-D	1050	324	353	386	422	461	-	-	-	-			
030 (2.5)	DNQ			Cool	High	Y1	COOL-A	900	222	254	291	323	340	381	431	462	516
						Y1	COOL-B	1000	271	306	360	397	433	469	508	554	571
						Y1	COOL-C	1125	367	411	445	500	533	588	625	647	665
						Y1	COOL-D	1250	472	522	587	628	660	686	701	720	736
		Heat	N036	W1	HEAT-A	670	121	152	180	205	228	257	-	-	-		
				W1	HEAT-B	730	143	180	204	225	260	286	-	-	-		
				W1	HEAT-C	790	172	205	237	267	296	329	-	-	-		
				W1	HEAT-D	850	195	235	263	310	324	366	-	-	-		
			N056	W1	HEAT-A	1050	297	341	385	427	469	-	-	-	-		
				W1	HEAT-B	1135	379	417	455	496	536	-	-	-	-		
				W1	HEAT-C	1220	448	493	537	586	635	-	-	-	-		
				W1	HEAT-D	1300	514	562	610	655	700	-	-	-	-		
			D056	W1	HEAT-A	680	130	161	189	214	237	-	-	-	-		
				W1	HEAT-B	735	150	185	212	229	269	-	-	-	-		
				W1	HEAT-C	790	172	205	237	267	296	-	-	-	-		
				W1	HEAT-D	840	204	244	272	319	333	-	-	-	-		
		W1+W2		HEAT-A	1050	297	341	385	427	469	-	-	-	-			
		W1+W2		HEAT-B	1135	379	417	455	496	536	-	-	-	-			
		W1+W2		HEAT-C	1220	448	493	537	586	635	-	-	-	-			
		W1+W2		HEAT-D	1300	514	562	610	655	700	-	-	-	-			

DNX/DNQ024-060 (Continued)

Size (Tons)	Model	Mode	Thermostat Input	Speed Tap	CFM	External Static Pressure (Inch Water Gauge)									
						0.2	0.3	0.4	0.5	0.6	0.7	0.8	0.9	1.0	
						Watts	Watts	Watts	Watts	Watts	Watts	Watts	Watts	Watts	
036 (3.0)	DNQ	Cool	High	Y1	COOL-A	1100	363	410	459	509	559	611	664	719	773
				Y1	COOL-B	1050	328	375	424	474	524	576	629	684	738
				Y1	COOL-C	1200	439	489	541	595	652	710	771	835	900
				Y1	COOL-D	1350	576	626	680	737	798	863	932	1005	-
		N036	W1	HEAT-A	670	162	194	227	258	289	320	-	-	-	-
			W1	HEAT-B	730	177	213	248	283	318	352	-	-	-	-
			W1	HEAT-C	790	196	235	274	312	350	388	-	-	-	-
			W1	HEAT-D	850	220	261	303	344	385	426	-	-	-	-
		N056	W1	HEAT-A	1050	328	375	424	474	524	-	-	-	-	-
			W1	HEAT-B	1135	388	437	488	540	594	-	-	-	-	-
			W1	HEAT-C	1220	456	506	558	613	670	-	-	-	-	-
			W1	HEAT-D	1300	528	578	631	687	747	-	-	-	-	-
		Heat	D056	W1	HEAT-A	680	164	197	230	262	294	-	-	-	-
				W1	HEAT-B	735	178	215	250	286	321	-	-	-	-
				W1	HEAT-C	790	196	235	274	312	350	-	-	-	-
				W1	HEAT-D	840	216	257	297	338	379	-	-	-	-
			N072	W1+W2	HEAT-A	1050	328	375	424	474	524	-	-	-	-
				W1+W2	HEAT-B	1140	392	441	491	544	598	-	-	-	-
				W1+W2	HEAT-C	1220	456	506	558	613	670	-	-	-	-
				W1+W2	HEAT-D	1300	528	578	631	687	747	-	-	-	-
		D072	W1	HEAT-A	1200	439	489	541	595	-	-	-	-	-	
			W1	HEAT-B	1300	528	578	631	687	-	-	-	-	-	
			W1	HEAT-C	1400	628	677	731	789	-	-	-	-	-	
			W1	HEAT-D	1475	710	759	812	871	-	-	-	-	-	
		N090	W1	HEAT-A	790	196	235	274	312	-	-	-	-	-	
			W1	HEAT-B	855	222	264	305	347	-	-	-	-	-	
			W1	HEAT-C	920	252	296	341	385	-	-	-	-	-	
			W1	HEAT-D	975	282	328	374	421	-	-	-	-	-	
W1+W2	HEAT-A		1200	439	489	541	595	-	-	-	-	-			
W1+W2	HEAT-B		1300	528	578	631	687	-	-	-	-	-			
W1+W2	HEAT-C		1400	628	677	731	789	-	-	-	-	-			
W1+W2	HEAT-D		1480	716	764	818	877	-	-	-	-	-			
036 (3.0)	DNX	Cool	Low	Y1	COOL-A	900	198	233	272	313	358	406	458	512	569
				Y1	COOL-B	760	166	190	222	262	310	366	431	503	584
				Y1	COOL-C	830	180	210	245	286	332	384	441	503	571
				Y1	COOL-D	970	221	260	302	344	388	434	481	530	579
		High	Y1+Y2	COOL-A	1250	361	408	454	501	548	594	640	687	733	
			Y1+Y2	COOL-B	1050	253	296	340	384	428	472	516	561	605	
			Y1+Y2	COOL-C	1150	302	348	394	439	484	528	571	615	657	
			Y1+Y2	COOL-D	1350	429	475	522	570	620	671	723	777	831	
		Heat	N065	W1	HEAT-A	1200	330	377	423	469	515	560	-	-	-
				W1	HEAT-B	1300	394	440	487	535	583	631	-	-	-
				W1	HEAT-C	1400	467	511	558	607	659	713	-	-	-
				W1	HEAT-D	1500	550	590	635	686	743	804	-	-	-
			N090	W1	HEAT-A	1150	302	348	394	439	484	528	-	-	-
				W1	HEAT-B	1225	345	392	439	485	531	577	-	-	-
				W1	HEAT-C	1275	377	424	471	518	565	612	-	-	-
				W1	HEAT-D	1350	429	475	522	570	620	671	-	-	-
		D090	W1	HEAT-A	740	163	185	216	255	304	362	-	-	-	
			W1	HEAT-B	785	170	196	230	270	317	372	-	-	-	
			W1	HEAT-C	825	178	208	243	284	330	382	-	-	-	
			W1	HEAT-D	870	189	223	260	301	347	396	-	-	-	
W1+W2	W1+W2	HEAT-A	1150	302	348	394	439	484	528	-	-	-			
	W1+W2	HEAT-B	1220	342	389	436	482	528	573	-	-	-			
	W1+W2	HEAT-C	1280	380	427	474	521	568	616	-	-	-			
	W1+W2	HEAT-D	1350	429	475	522	570	620	671	-	-	-			

DNX/DNQ024-060 (Continued)

Size (Tons)	Model	Mode	Thermostat Input	Speed Tap	CFM	External Static Pressure (Inch Water Gauge)											
						0.2	0.3	0.4	0.5	0.6	0.7	0.8	0.9	1.0			
						Watts	Watts	Watts	Watts	Watts	Watts	Watts	Watts	Watts			
042 (3.5)	DNQ	Cool	High	Y1	COOL-A	1400	466	513	561	611	663	715	770	826	882		
				Y1	COOL-B	1350	430	476	523	571	621	672	718	766	815		
				Y1	COOL-C	1500	544	596	648	702	758	815	867	921	975		
				Y1	COOL-D	1600	630	687	745	804	864	926	988	1052	1116		
		N065	W1	HEAT-A	1200	330	373	416	461	507	554	-	-	-			
			W1	HEAT-B	1300	394	439	484	531	579	629	-	-	-			
			W1	HEAT-C	1400	466	513	561	611	663	715	-	-	-			
			W1	HEAT-D	1500	544	596	648	702	758	815	-	-	-			
		N090	W1	HEAT-A	1325	412	456	503	550	599	649	-	-	-			
			W1	HEAT-B	1400	466	513	561	611	663	715	-	-	-			
			W1	HEAT-C	1500	544	596	648	702	758	815	-	-	-			
			W1	HEAT-D	1600	630	687	745	804	864	926	-	-	-			
		Heat	D090	W1	HEAT-A	870	168	215	261	306	350	393	-	-	-		
				W1	HEAT-B	920	188	233	278	322	366	409	-	-	-		
				W1	HEAT-C	985	216	260	303	347	391	434	-	-	-		
				W1	HEAT-D	1050	247	290	333	376	420	464	-	-	-		
			W1+W2	W1+W2	HEAT-A	1330	415	460	506	554	603	653	-	-	-		
				W1+W2	HEAT-B	1400	466	513	561	611	663	715	-	-	-		
				W1+W2	HEAT-C	1500	544	596	648	702	758	815	-	-	-		
				W1+W2	HEAT-D	1600	630	687	745	804	864	926	-	-	-		
		048 (4.0)	DNQ	Cool	High	Y1	COOL-A	1500	544	596	648	702	758	815	867	921	975
						Y1	COOL-B	1400	466	513	561	611	663	715	770	826	882
						Y1	COOL-C	1600	630	687	745	804	864	926	988	1052	1116
						Y1	COOL-D	1700	723	787	851	916	982	1049	1116	1185	1247
				N065	W1	HEAT-A	1200	330	373	416	461	507	554	-	-	-	
					W1	HEAT-B	1300	394	439	484	531	579	629	-	-	-	
					W1	HEAT-C	1400	466	513	561	611	663	715	-	-	-	
					W1	HEAT-D	1500	544	596	648	702	758	815	-	-	-	
N090	W1			HEAT-A	1325	412	456	503	550	599	649	-	-	-			
	W1			HEAT-B	1400	466	513	561	611	663	715	-	-	-			
	W1			HEAT-C	1500	544	596	648	702	758	815	-	-	-			
	W1			HEAT-D	1600	630	687	745	804	864	926	-	-	-			
Heat	D090			W1	HEAT-A	870	168	215	261	306	350	393	-	-	-		
				W1	HEAT-B	920	188	233	278	322	366	409	-	-	-		
				W1	HEAT-C	985	216	260	303	347	391	434	-	-	-		
				W1	HEAT-D	1050	247	290	333	376	420	464	-	-	-		
	W1+W2			W1+W2	HEAT-A	1330	415	460	506	554	603	653	-	-	-		
				W1+W2	HEAT-B	1400	466	513	561	611	663	715	-	-	-		
				W1+W2	HEAT-C	1500	544	596	648	702	758	815	-	-	-		
				W1+W2	HEAT-D	1600	630	687	745	804	864	926	-	-	-		
N110	W1			HEAT-A	1450	504	553	604	656	-	-	-	-	-			
	W1			HEAT-B	1500	544	596	648	702	-	-	-	-	-			
	W1			HEAT-C	1600	630	687	745	804	-	-	-	-	-			
	W1			HEAT-D	1700	723	787	851	916	-	-	-	-	-			
D110	W1			HEAT-A	940	196	241	285	329	-	-	-	-	-			
	W1			HEAT-B	970	209	253	297	341	-	-	-	-	-			
	W1			HEAT-C	1050	247	290	333	376	-	-	-	-	-			
	W1			HEAT-D	1100	273	315	358	402	-	-	-	-	-			
	W1+W2	HEAT-A	1450	504	553	604	656	-	-	-	-	-					
	W1+W2	HEAT-B	1500	544	596	648	702	-	-	-	-	-					
W1+W2	HEAT-C	1600	630	687	745	804	-	-	-	-	-						
W1+W2	HEAT-D	1700	723	787	851	916	-	-	-	-	-						

DNX/DNQ024-060 (Continued)

Size (Tons)	Model	Mode	Thermostat Input	Speed Tap	CFM	External Static Pressure (Inch Water Gauge)									
						0.2	0.3	0.4	0.5	0.6	0.7	0.8	0.9	1.0	
						Watts	Watts	Watts	Watts	Watts	Watts	Watts	Watts	Watts	
048 (4.0)	DNX	Cool	Low	Y1	COOL-A	1030	237	280	323	367	411	455	499	543	588
				Y1	COOL-B	930	192	237	282	326	369	413	455	497	539
				Y1	COOL-C	1070	257	300	343	386	430	475	520	565	611
				Y1	COOL-D	1130	289	332	375	419	463	509	555	602	649
			High	Y1+Y2	COOL-A	1550	586	640	696	752	810	869	929	991	1053
				Y1+Y2	COOL-B	1400	466	513	561	611	663	715	770	826	882
				Y1+Y2	COOL-C	1600	630	687	745	804	864	926	988	1052	1116
				Y1+Y2	COOL-D	1700	723	787	851	916	982	1049	1116	1185	-
		Heat	N065	W1	HEAT-A	1200	330	373	416	461	507	554	-	-	-
				W1	HEAT-B	1300	394	439	484	531	579	629	-	-	-
				W1	HEAT-C	1400	466	513	561	611	663	715	-	-	-
				W1	HEAT-D	1500	544	596	648	702	758	815	-	-	-
			N090	W1	HEAT-A	1325	412	456	503	550	599	649	-	-	-
				W1	HEAT-B	1400	466	513	561	611	663	715	-	-	-
				W1	HEAT-C	1500	544	596	648	702	758	815	-	-	-
				W1	HEAT-D	1600	630	687	745	804	864	926	-	-	-
			D090	W1	HEAT-A	870	168	215	261	306	350	393	-	-	-
				W1	HEAT-B	920	188	233	278	322	366	409	-	-	-
				W1	HEAT-C	985	216	260	303	347	391	434	-	-	-
				W1	HEAT-D	1050	247	290	333	376	420	464	-	-	-
				W1+W2	HEAT-A	1330	415	460	506	554	603	653	-	-	-
				W1+W2	HEAT-B	1400	466	513	561	611	663	715	-	-	-
				W1+W2	HEAT-C	1500	544	596	648	702	758	815	-	-	-
				W1+W2	HEAT-D	1600	630	687	745	804	864	926	-	-	-
N110	W1	HEAT-A	1450	504	553	604	656	-	-	-	-	-			
	W1	HEAT-B	1500	544	596	648	702	-	-	-	-	-			
	W1	HEAT-C	1600	630	687	745	804	-	-	-	-	-			
	W1	HEAT-D	1700	723	787	851	916	-	-	-	-	-			
D110	W1	HEAT-A	940	196	241	285	329	-	-	-	-	-			
	W1	HEAT-B	970	209	253	297	341	-	-	-	-	-			
	W1	HEAT-C	1050	247	290	333	376	-	-	-	-	-			
	W1	HEAT-D	1100	273	315	358	402	-	-	-	-	-			
	W1+W2	HEAT-A	1450	504	553	604	656	-	-	-	-	-			
	W1+W2	HEAT-B	1500	544	596	648	702	-	-	-	-	-			
	W1+W2	HEAT-C	1600	630	687	745	804	-	-	-	-	-			
	W1+W2	HEAT-D	1700	723	787	851	916	-	-	-	-	-			
060 (5.0)	DNQ	Cool	High	Y1	COOL-A	1550	438	480	522	609	696	736	803	866	930
				Y1	COOL-B	1650	510	554	598	690	782	826	896	963	1031
				Y1	COOL-C	1750	589	635	682	778	873	924	995	1066	1137
				Y1	COOL-D	2000	822	875	927	1027	1128	1198	-	-	-
		Heat	N065	W1	HEAT-A	1200	251	285	319	382	445	475	-	-	-
				W1	HEAT-B	1300	295	331	367	438	509	541	-	-	-
				W1	HEAT-C	1400	346	385	423	501	579	613	-	-	-
				W1	HEAT-D	1500	405	446	487	572	656	693	-	-	-
			N090	W1	HEAT-A	1325	307	344	381	453	526	558	-	-	-
				W1	HEAT-B	1400	346	385	423	501	579	613	-	-	-
				W1	HEAT-C	1500	405	446	487	572	656	693	-	-	-
				W1	HEAT-D	1600	473	516	559	649	738	780	-	-	-
			D090	W1	HEAT-A	870	165	191	218	246	275	307	-	-	-
				W1	HEAT-B	920	172	200	228	262	296	328	-	-	-
				W1	HEAT-C	985	185	214	243	285	326	357	-	-	-
				W1	HEAT-D	1050	201	232	263	311	359	389	-	-	-
				W1+W2	HEAT-A	1330	309	346	383	456	530	562	-	-	-
				W1+W2	HEAT-B	1400	346	385	423	501	579	613	-	-	-
				W1+W2	HEAT-C	1500	405	446	487	572	656	693	-	-	-
				W1+W2	HEAT-D	1600	473	516	559	649	738	780	-	-	-
		N110	W1	HEAT-A	1450	375	414	454	536	617	652	-	-	-	
			W1	HEAT-B	1500	405	446	487	572	656	693	-	-	-	
			W1	HEAT-C	1600	473	516	559	649	738	780	-	-	-	
			W1	HEAT-D	1700	548	594	639	733	827	874	-	-	-	
D110	W1	HEAT-A	940	176	204	232	269	305	336	-	-	-			
	W1	HEAT-B	985	185	214	243	285	326	357	-	-	-			
	W1	HEAT-C	1035	197	227	258	305	351	381	-	-	-			
	W1	HEAT-D	1100	216	248	279	333	386	416	-	-	-			
	W1+W2	HEAT-A	1450	375	414	454	536	617	652	-	-	-			
	W1+W2	HEAT-B	1500	405	446	487	572	656	693	-	-	-			
	W1+W2	HEAT-C	1600	473	516	559	649	738	780	-	-	-			
	W1+W2	HEAT-D	1700	548	594	639	733	827	874	-	-	-			

Additional Static Resistance

Size (Tons)	Model	CFM	Wet Indoor Coil	Economizer ¹	Filter/Frame Kit	Electric Heat
024 (2.0)	DNZ DNQ DNX	500	0.01	0.00	0.01	-
		600	0.01	0.00	0.02	-
		700	0.01	0.00	0.04	-
		800	0.02	0.01	0.06	-
		900	0.03	0.01	0.08	-
		1000	0.04	0.01	0.10	-
		1100	0.05	0.01	0.13	-
030 (2.5)	DNZ DNQ	700	0.01	0.00	0.04	-
		800	0.02	0.01	0.06	-
		900	0.03	0.01	0.08	-
		1000	0.04	0.01	0.10	-
		1100	0.05	0.01	0.13	-
		1200	0.06	0.02	0.16	-
		1300	0.07	0.03	0.17	-
036 (3.0)	DNZ DNQ DNX	700	0.01	0.00	0.04	-
		800	0.02	0.01	0.06	-
		900	0.03	0.01	0.08	-
		1000	0.04	0.01	0.10	-
		1100	0.05	0.01	0.13	-
		1200	0.06	0.02	0.16	-
		1300	0.07	0.03	0.17	-
042 (3.5)	DNZ DNQ	1100	0.02	0.02	0.04	-
		1200	0.03	0.02	0.04	-
		1300	0.04	0.02	0.05	-
		1400	0.05	0.03	0.05	-
		1500	0.06	0.04	0.06	-
		1600	0.07	0.04	0.07	-
		1700	0.07	0.04	0.08	-
048 (4.0)	DNZ DNQ DNX	1800	0.08	0.04	0.09	-
		1900	0.09	0.05	0.10	-
		2000	0.09	0.05	0.11	-
		1100	0.02	0.02	0.04	-
		1200	0.03	0.02	0.04	-
		1300	0.04	0.02	0.05	-
		1400	0.05	0.03	0.05	-
060 (5.0)	DNZ DNQ	1500	0.06	0.04	0.06	-
		1600	0.07	0.04	0.07	-
		1700	0.07	0.04	0.08	-
		1800	0.08	0.04	0.09	-
		1900	0.09	0.05	0.10	-
		2000	0.09	0.05	0.11	-
		1400	0.05	0.03	0.05	-

1. The pressure drop through the economizer is greater for 100% outdoor air than for 100% return air. If the resistance of the return air duct is less than 0.25 IWG, the unit will deliver less CFM during full economizer operation.

Gas Heat Minimum Supply Air

Size (Tons)	Model	Heat Size	Supply Air (CFM)			
			Cooling		Heating	
			Min	Max	Min	Max
024 (2.0)	DNZ	N036	600	1000	610	1330
		D056	600	1000	860	1730
	DNQ	N036	450	900	610	1330
		N056	450	900	860	1730
	DNX	N036	450	900	610	1330
		D056	450	900	860	1730
030 (2.5)	DNZ DNQ	N036	750	1250	610	1330
		N056	750	1250	860	1730
	D056	750	1250	860	1730	
036 (3.0)	DNZ	N036	1200	1500	610	1330
		N056	1200	1500	940	2070
		D056	1200	1500	940	2070
		N072	1200	1500	1110	2220
	DNQ	D072	1200	1500	1110	2220
		N036	700	1350	610	1330
		N056	700	1350	940	2070
		D056	700	1350	940	2070
	DNX	N072	700	1350	1110	2220
		D072	700	1350	1110	2220
		N065	685	1350	1080	2370
		N090	685	1350	1070	1780
042 (3.5)	DNZ DNQ	D090	685	1350	1070	1780
		N065	1050	1750	1080	2370
	N090	1050	1750	1070	1780	
048 (4.0)	DNZ	D090	1050	1750	1070	1780
		N065	1200	2000	1080	2370
		N090	1200	2000	1230	2290
		D090	1200	2000	1230	2290
	DNQ	N110	1200	2000	1330	2220
		D110	1200	2000	1330	2220
		N065	930	1700	1080	2370
		N090	930	1700	1230	2290
	DNX	D090	930	1700	1230	2290
		N110	930	1700	1330	2220
		D110	930	1700	1330	2220
		N065	930	1700	1080	2370
060 (5.0)	DNZ	N090	930	1700	1230	2290
		D090	930	1700	1230	2290
		N110	930	1700	1330	2220
		D110	930	1700	1330	2220
	DNQ	N065	1500	2100	1080	2370
		N090	1500	2100	1230	2290
		D090	1500	2100	1230	2290
		N110	1500	2100	1330	2220
		D110	1500	2100	1330	2220
		N065	1060	1800	1080	2370

Indoor Blower Specifications

Size (Tons)	Model	Motor				
		HP	RPM	Eff.	SF	Frame
024 (2.0)	DNZ	1/2	Variable	0.8	1.0	48
	DNQ					
	DNX					
030 (2.5)	DNZ	1/2	Variable	0.8	1.0	48
	DNQ					
036 (3.0)	DNZ	3/4	Variable	0.8	1.0	48
	DNQ					
	DNX					
042 (3.5)	DNZ	1	Variable	0.8	1.0	48
	DNQ					
048 (4.0)	DNZ	1	Variable	0.8	1.0	48
	DNQ					
	DNX					
060 (5.0)	DNZ	1	Variable	0.8	1.0	48
	DNQ					

Electric Heat Multipliers

Voltage		kW Capacity Multipliers ¹
Nominal	Applied	
240	208	0.75
	230	0.92
480	460	0.92
600	575	0.92

1. Electric heaters are rated at nominal voltage. Use this table to determine the electric heat capacity for heaters applied at lower voltages.

Sound Performance

Outdoor Sound Power Levels

Size (Tons)	Model	Sound Rating ¹ dB (A)	Octave Band Centerline Frequency (Hz)						
			125	250	500	1000	2000	4000	8000
024 (2.0)	DNZ	77	64	65.5	68	72.5	64.5	60.5	48.5
	DNQ	80	66	70.5	74	74.5	72.5	67.5	64.5
	DNX	80	66	70.5	74	74.5	72.5	67.5	64.5
030 (2.5)	DNZ	74	63.5	64.5	66.5	67	63	57.5	51.5
	DNQ								
036 (3.0)	DNZ	74	66.5	66.5	69.5	68	63	59	49.5
	DNQ	79.5	69	71.5	74	74	70.5	67	61
	DNX	80	70.5	71	74.5	74	71	67.5	64
042 (3.5)	DNZ	79	70	70.5	73.5	73	69.5	67	66
	DNQ								
048 (4.0)	DNZ	79	70.5	71	73.5	73	70	66	66
	DNQ	80	71.5	71.5	73.5	74	69.5	65	63.5
	DNX	81	72.5	73	76	75.5	71	67.5	65
060 (5.0)	DNZ	80	73	71.5	74.5	75	70.5	67	62.5
	DNQ	81	73.5	73	76	75.5	71	66.5	61.5

1. Rated in accordance with ARI 270 standard.

Electrical Data

DNQ024-060 Gas Heat

Size (Tons) DNQ	Volt	Compressors (each)			OD Fan Motors (each)	Supply Blower Motor	MCA ¹ (Amps)	Max Fuse ² / Breaker ³ Size (Amps)
		RLA	LRA	MCC	FLA	FLA		
024 (2.0)	208/230-1-60	8.3	43	13	1.4	4.3	16.1	20
	208/230-1-60	14.1	73	22	1.4	6.8	25.8	35
030 (2.5)	208/230-3-60	8.9	58	14	1.4	6.8	19.3	25
	460-3-60	4.2	28	7	0.8	3.4	9.5	15
036 (3.0)	208/230-1-60	14.1	77	22	1.4	6.8	25.8	35
	208/230-3-60	9.0	71	14	1.4	6.8	19.5	25
	460-3-60	5.6	38	9	0.8	3.4	11.2	15
042 (3.5)	208/230-1-60	21.8	105	34	1.7	9.1	38.1	50
	208/230-3-60	14.1	95	22	1.7	9.1	28.4	35
	460-3-60	6.4	45	10	0.9	4.6	13.5	15
048 (4.0)	208/230-1-60	20.5	115	32	1.7	9.1	36.4	45
	208/230-3-60	16.0	120	25	1.7	9.1	30.8	40
	460-3-60	7.7	50	12	0.9	4.6	15.1	20
060 (5.0)	208/230-1-60	25.0	134	39	2.8	9.1	43.2	60
	208/230-3-60	15.9	110	25	2.8	9.1	31.8	40
	460-3-60	7.7	52	12	1.4	4.6	15.6	20

1. Minimum Circuit Ampacity.
2. Maximum Over Current Protection per standard UL 1995.
3. Fuse or HACR circuit breaker size installed at factory or field installed.

Typical DNQ024-048 Cooling Unit with Single Stage Gas Heat 208/230-1-60 volt Wiring Diagram

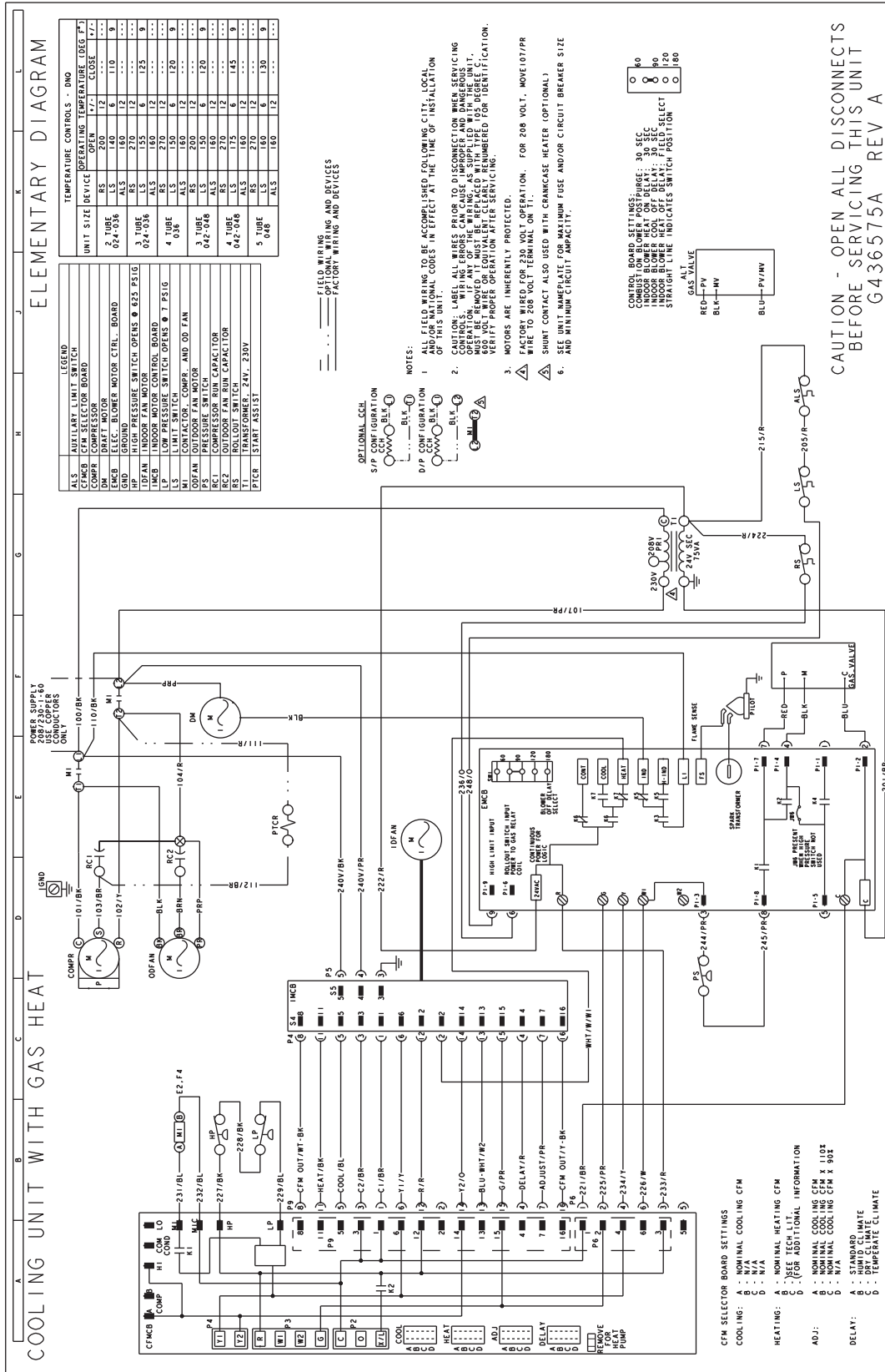

Typical DNQ060 Cooling Unit with Single Stage Gas Heat 208/230-1-60 volt Wiring Diagram

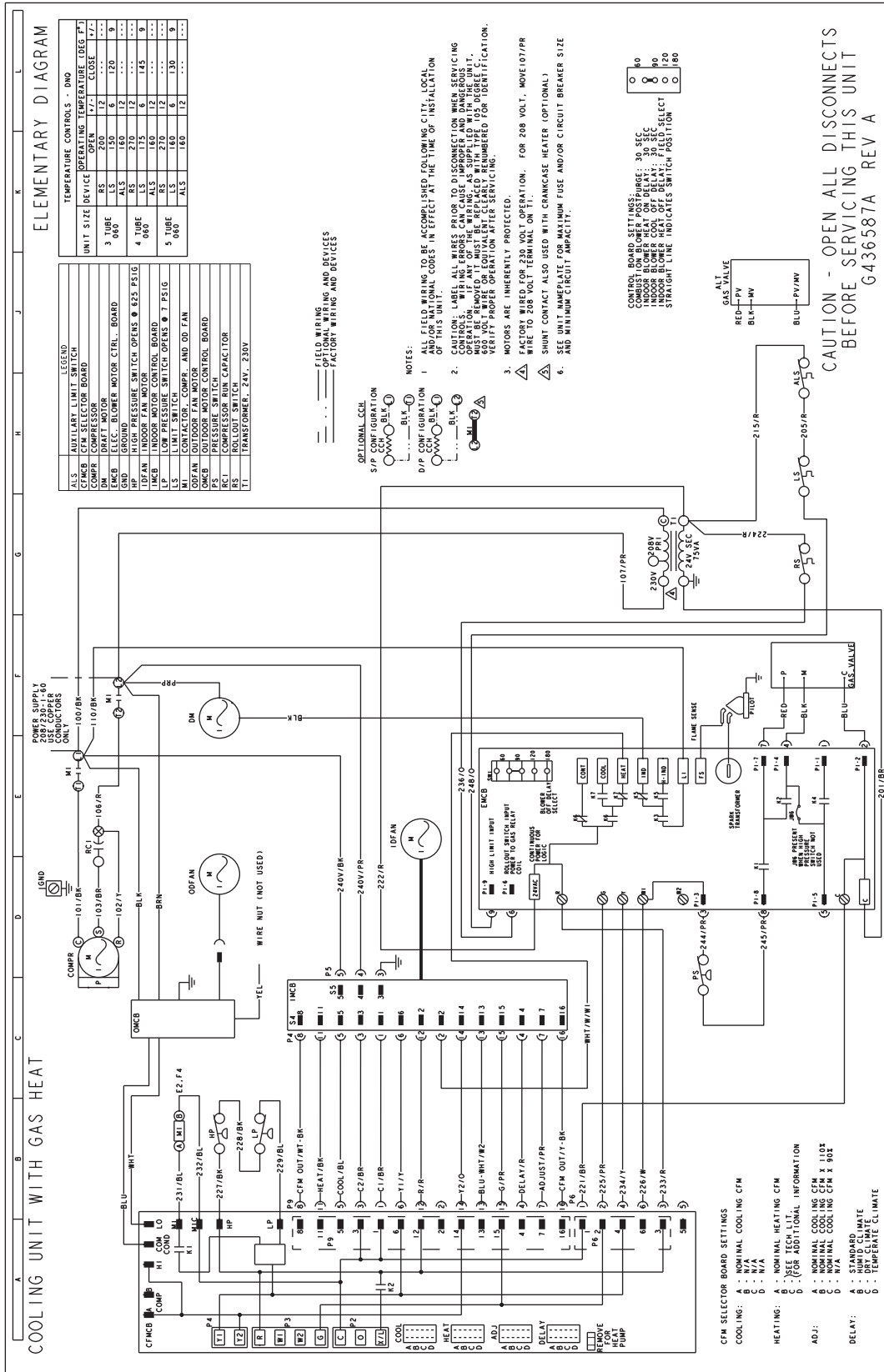

Typical DNQ060 Cooling Unit with Two Stage Gas Heat 208/230-1-60 volt Wiring Diagram

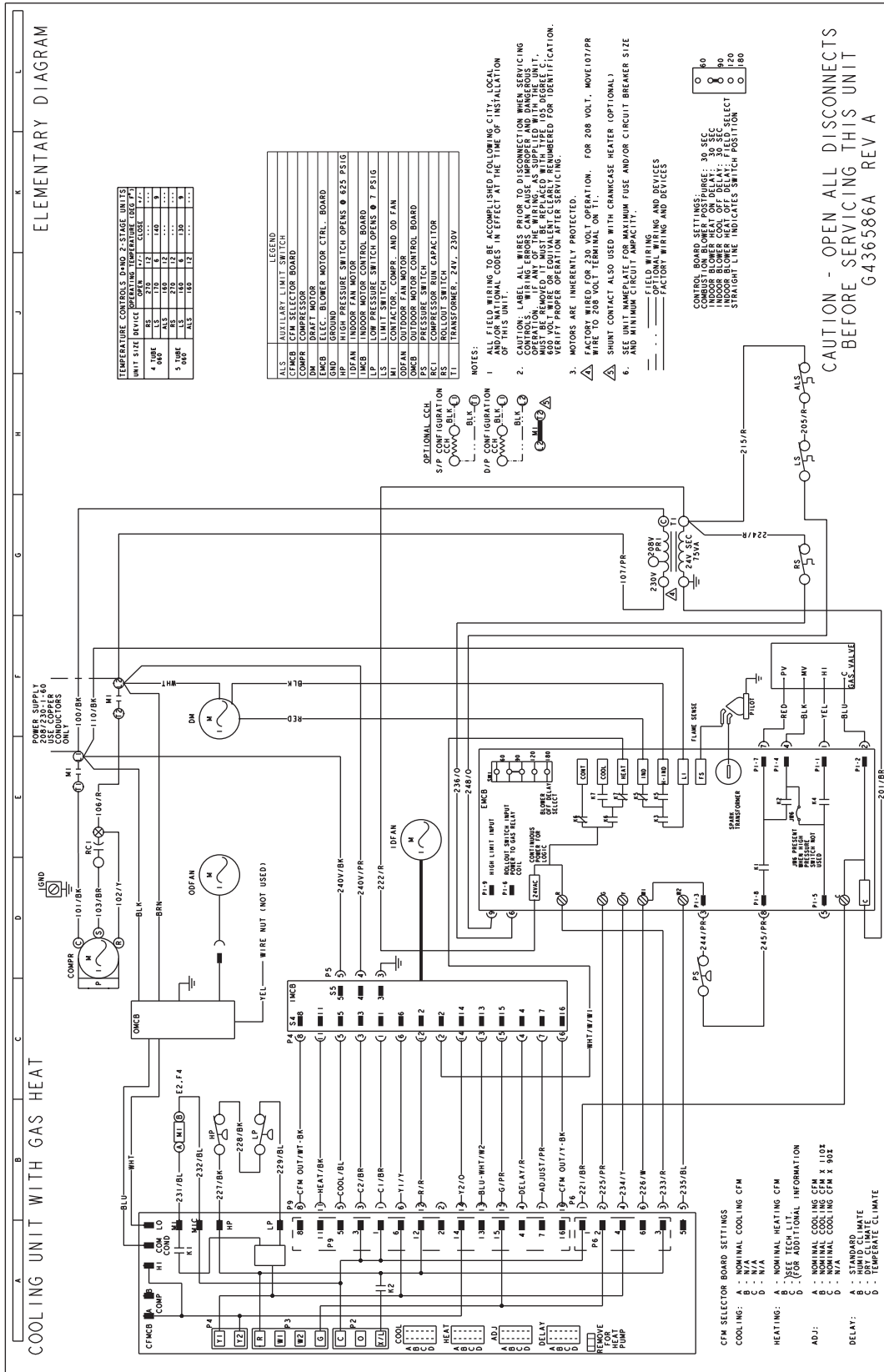

Typical DNQ036-048 Cooling Unit with Single Stage Gas Heat 208/230-3-60 volt Wiring Diagram

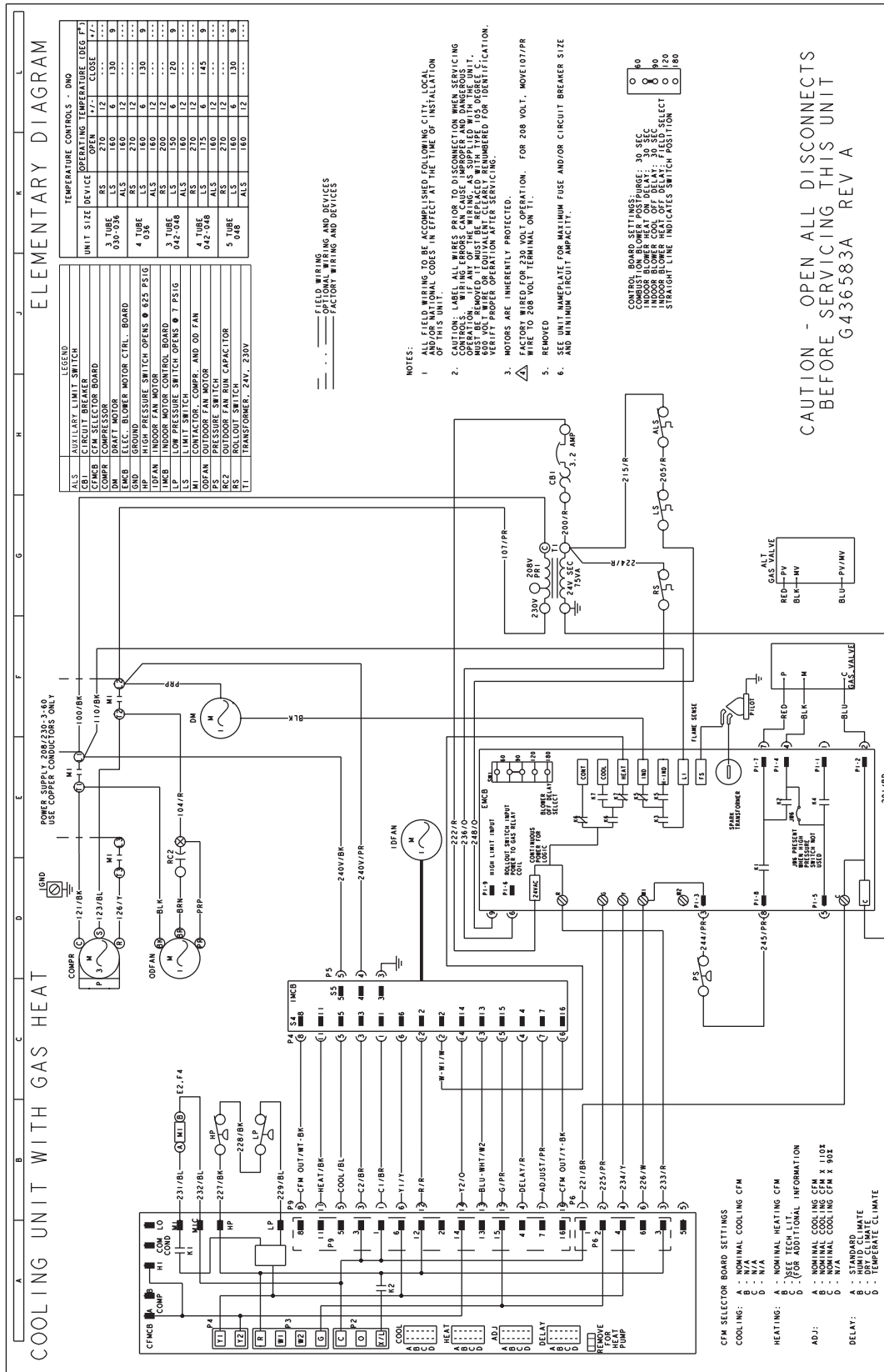

Typical DNQ060 Cooling Unit with Single Stage Gas Heat 460-3-60 volt Wiring Diagram

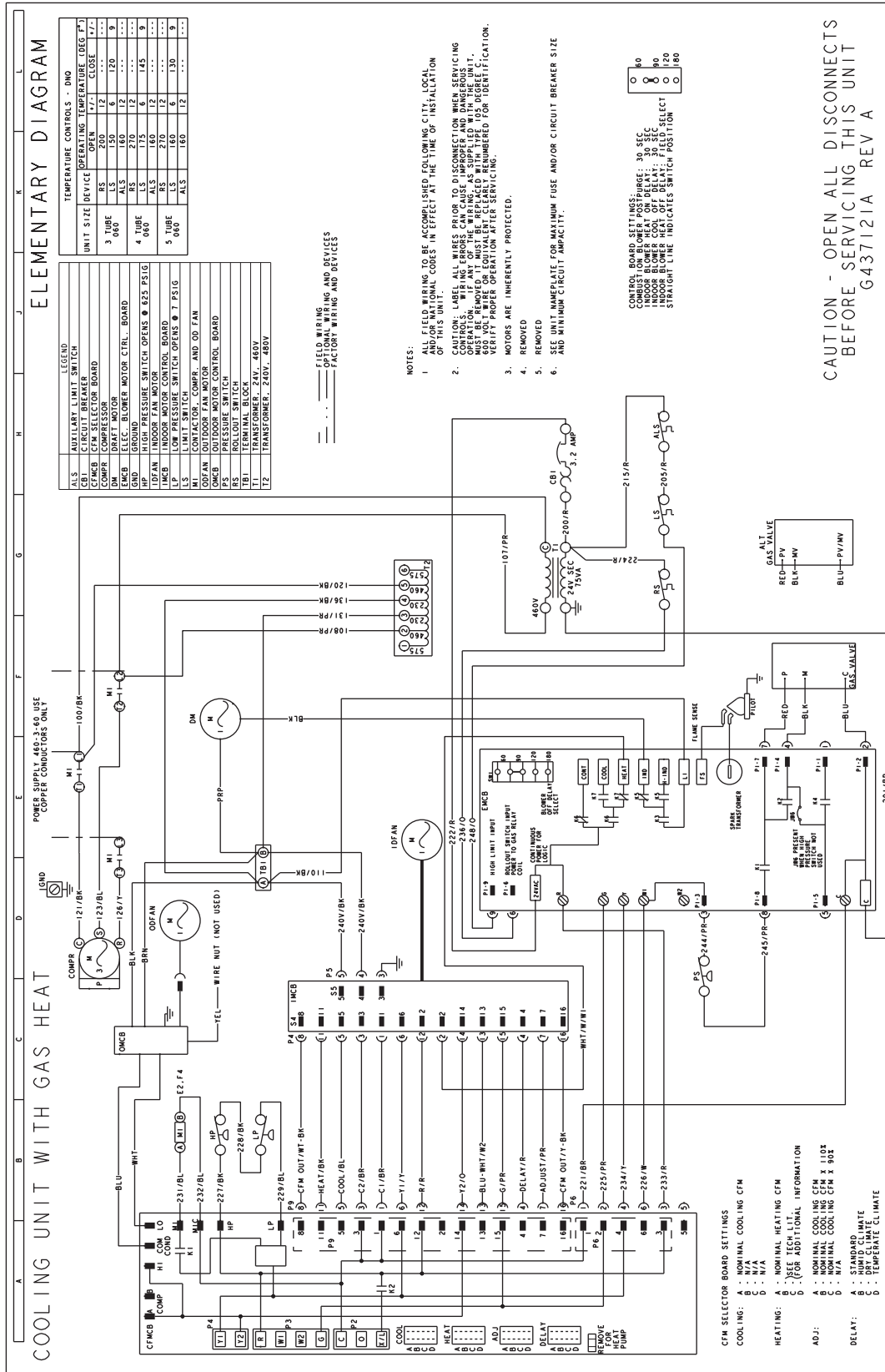

Typical DNQ060 Cooling Unit with Two Stage Gas Heat 460-3-60 volt Wiring Diagram

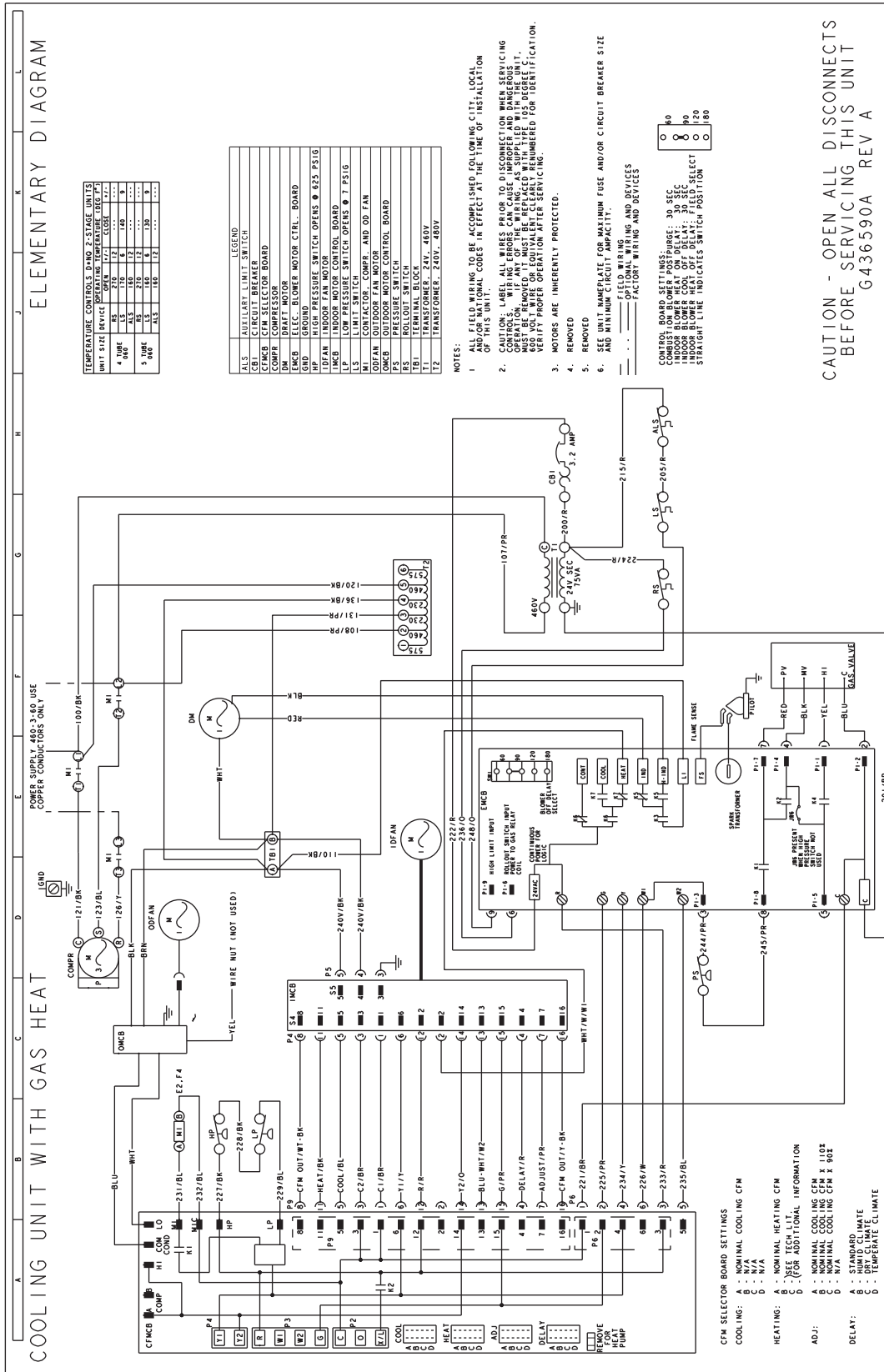

Weights and Dimensions

DNX, DNQ and DNZ Unit Weights

Unit 4 Point Load Weight

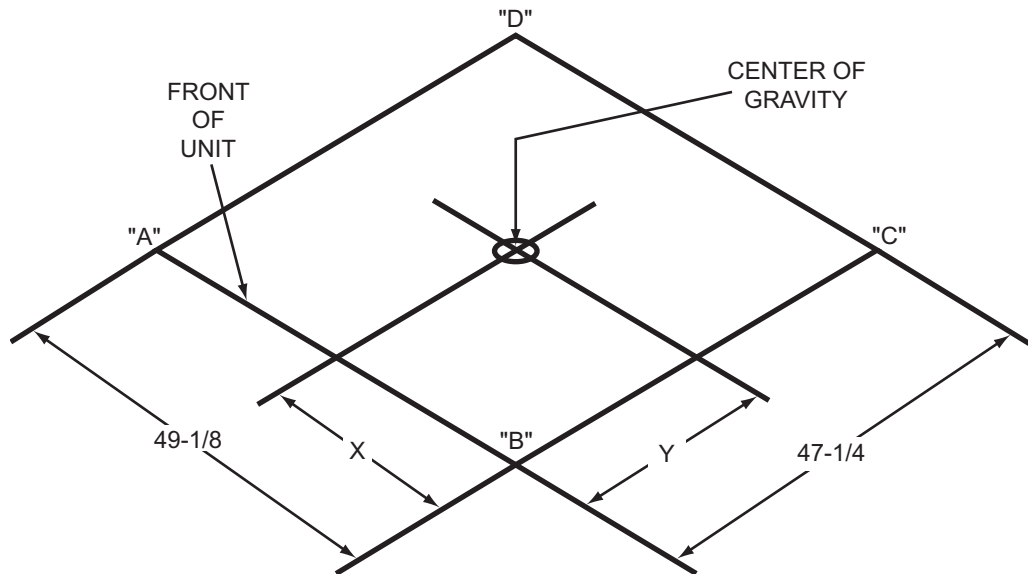

Size (Tons)	Model	Weight (lbs.)		Center of Gravity		4 Point Load Location (lbs.)			
		Shipping	Operating	X	Y	A	B	C	D
024 (2.0)	DNZ	383	378	23.8	20	77	77	112	112
	DNQ	395	390	20	24.5	113	81	82	114
	DNX	445	440	20	24.5	127	93	93	127
030 (2.5)	DNZ	403	398	24	20	81	81	119	117
	DNQ	430	425	20	24.25	122	88	90	125
036 (3.0)	DNZ	407	402	24	20	81	82	120	119
	DNQ	435	430	20	24.25	123	89	91	127
	DNX	485	480	20	24	136	98	103	143
042 (3.5)	DNZ	465	460	22.7	21.3	105	95	124	137
	DNQ	490	485	20	24	138	99	104	144
048 (4.0)	DNZ	470	465	22.7	21.3	106	96	125	138
	DNQ	495	490	20	24	139	100	105	146
	DNX	505	500	20	24	142	102	107	149
060 (5.0)	DNZ	485	480	23	21	106	99	132	142
	DNQ	535	530	20	24	150	108	114	158

Gas Unit Dimensions

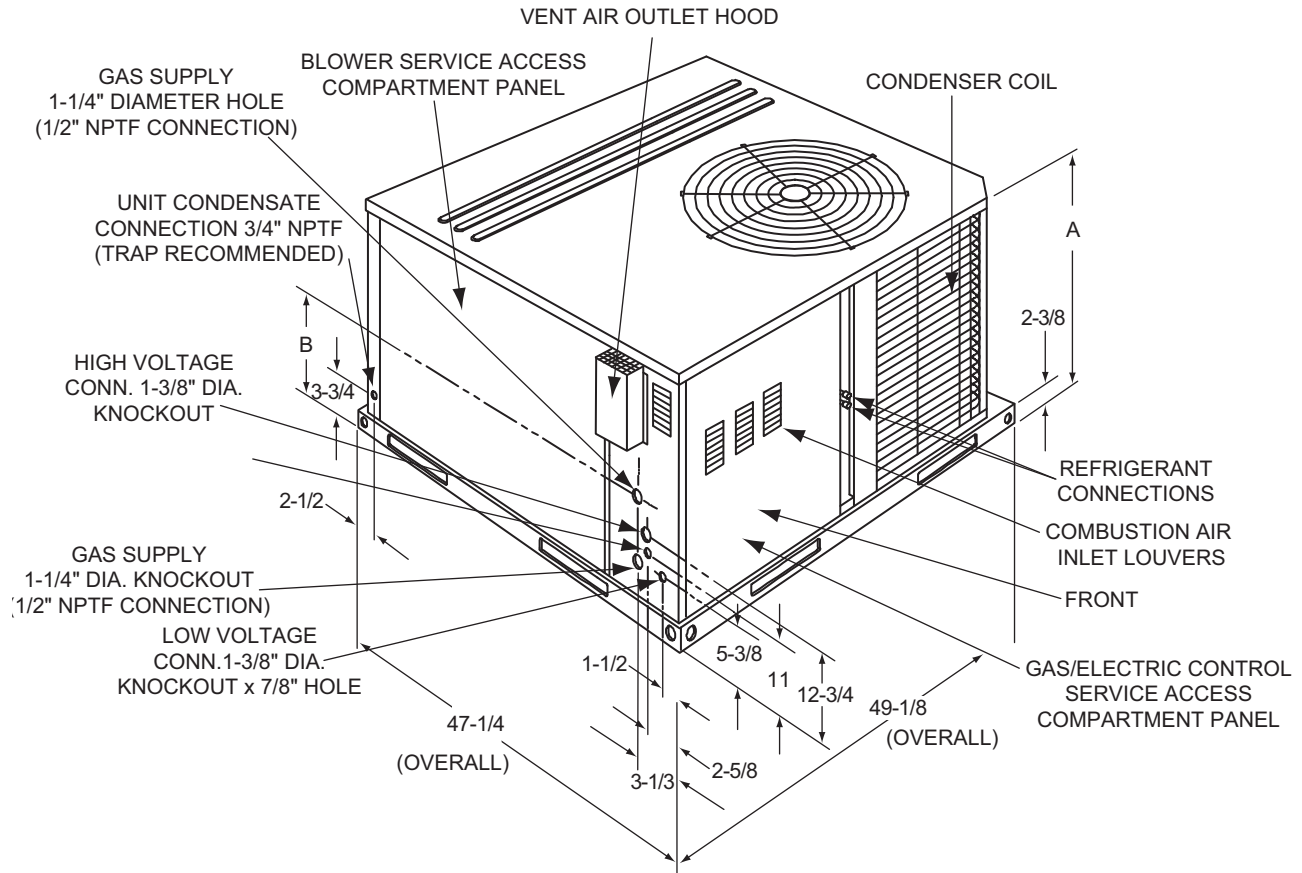

Gas Unit Dimensions

Unit Size	Dimensions	
	"A"	"B"
024, 030, 036 ¹	33-1/2	18-1/4
036 ² , 042, 048, 060	41-1/2	23-1/8

- 1. DNQ, DNZ Models.
- 2. DNX Models.

Gas Unit Clearances^{1 2}

Direction	Distance (in.)	Direction	Distance (in.)
Top ³	36	Right	12
Front	36	Left	24
Rear	0	Bottom ⁴	0

- 1. A 1" clearance must be provided between any combustible material and the supply air duct work.
- 2. The products of combustion must not be allowed to accumulate within a confined space and recirculate.
- 3. Units must be installed outdoors. Over hanging structure or shrubs should not obscure condenser air discharge outlet.
- 4. Units may be installed on combustible floors made from wood or class A, B or C roof covering materials.

Unit Accessory Weights

Unit Accessory	Model	Weight (lbs.)	
		Shipping	Operating
Add Economizer	All	45	40

Unit Dimensions Front and Bottom

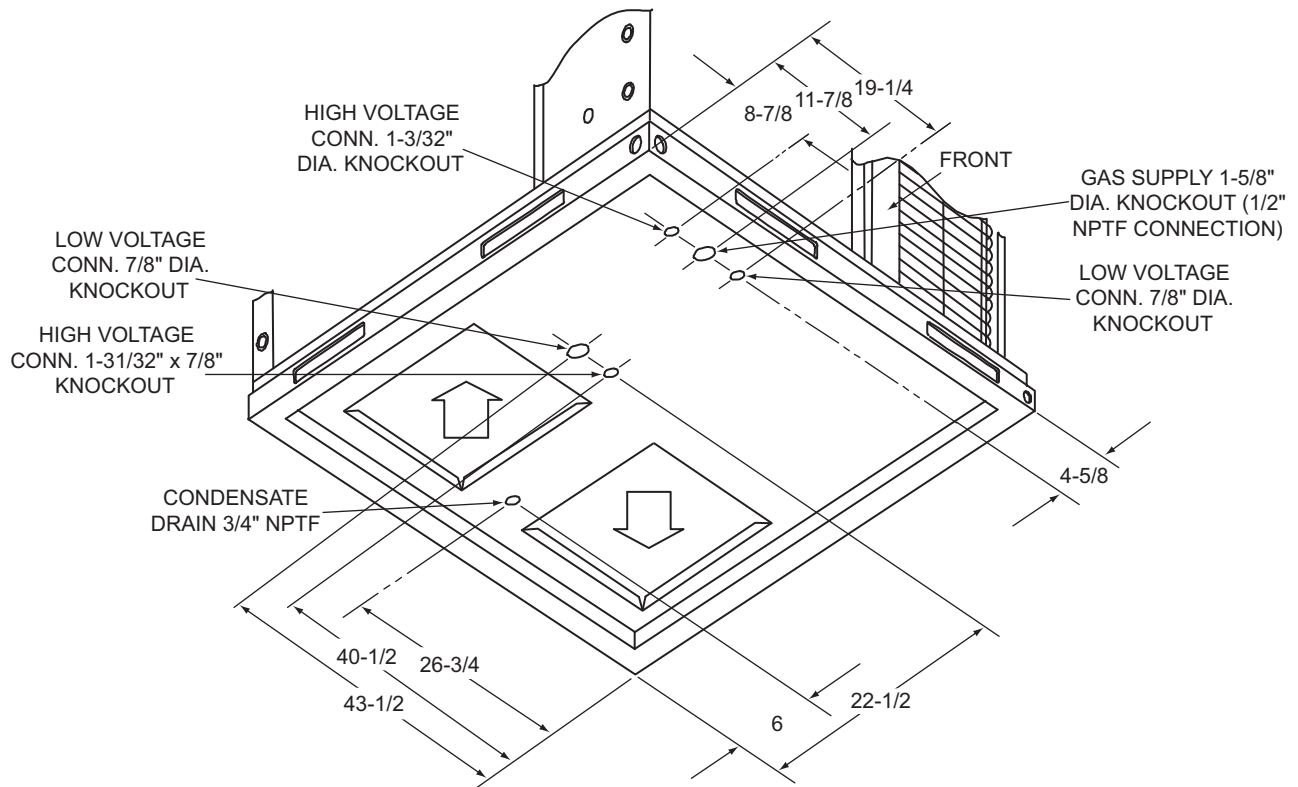

Unit Dimensions Back and Bottom

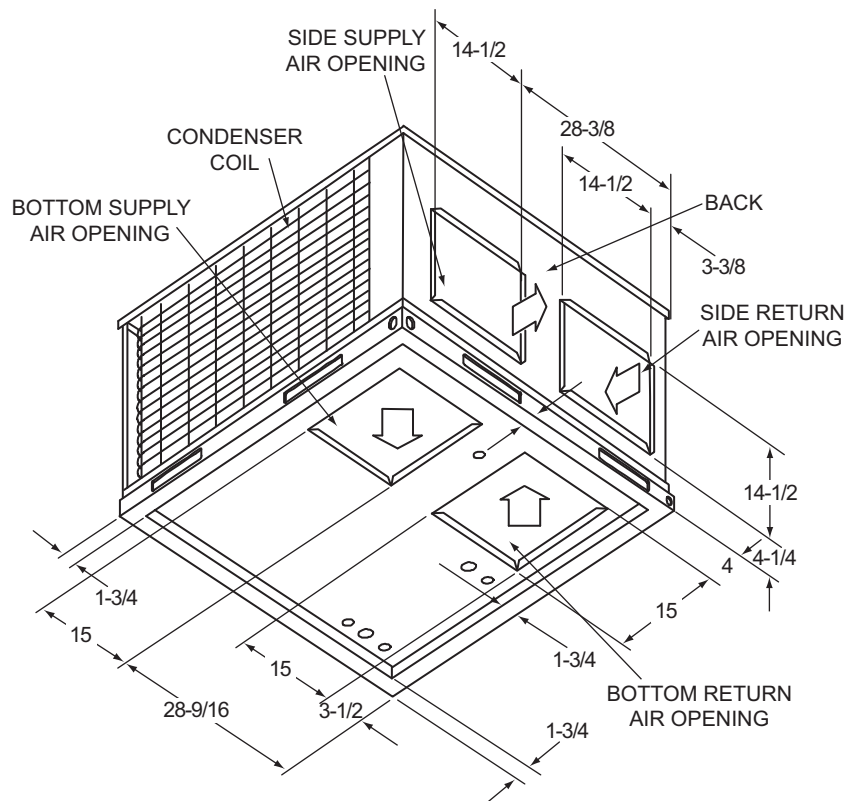

Unit Typical Duct Applications

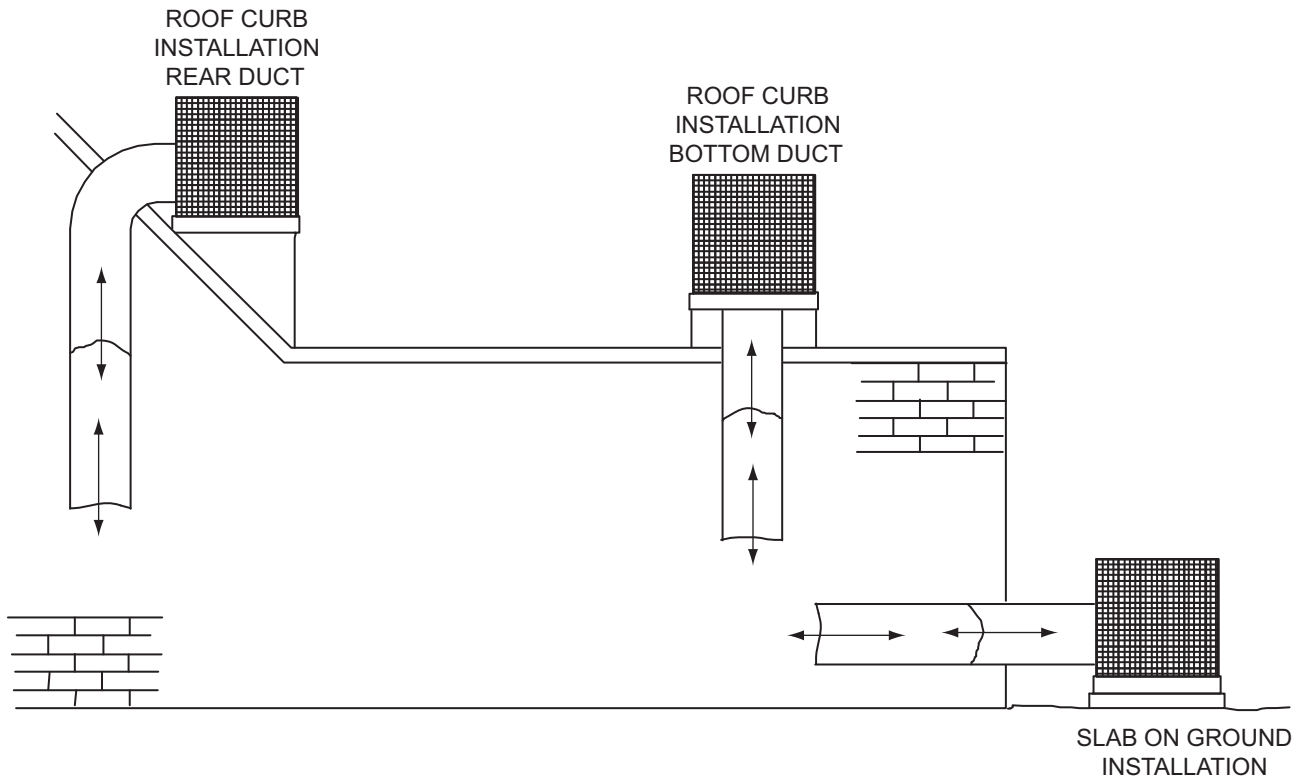

Unit Typical Slab on Ground Installation (Gas Model Shown)

