



Heating and Air Conditioning

TECHNICAL GUIDE

R-410A

ZF SERIES

6-1/2 - 12-1/2 TON

60 Hertz



ZF 6-1/2 THROUGH 10 TON



ZF 12-1/2 TON

PREDATOR[®]

Description

ASHRAE 90.1 COMPLIANT

YORK[®] Predator[®] units are convertible single packages with a common footprint cabinet and common roof curb for all 6-1/2 through 12-1/2 ton models. All units have two compressors with independent refrigeration circuits to provide 2 stages of cooling. The units were designed for light commercial applications and can be easily installed on a roof curb, slab, or frame.

All Predator[®] units are self-contained and assembled on rigid full perimeter base rails allowing for 3-way forklift access and overhead rigging. Every unit is completely charged, wired, piped, and tested at the factory to provide a quick and easy field installation.

All units are convertible between side and down airflow. Independent economizer designs are used on side and down discharge applications, as well as all tonnage sizes.

Predator[®] units are available in the following configurations: cooling only, cooling with electric heat, and cooling with gas heat. Electric heaters are available as factory-installed options or field-installed accessories.

All units provide constant supply air volume. A variable air volume (VAV) option, featuring a variable frequency drive, is available on 6-1/2 through 12-1/2 ton models.

Tested in accordance with:

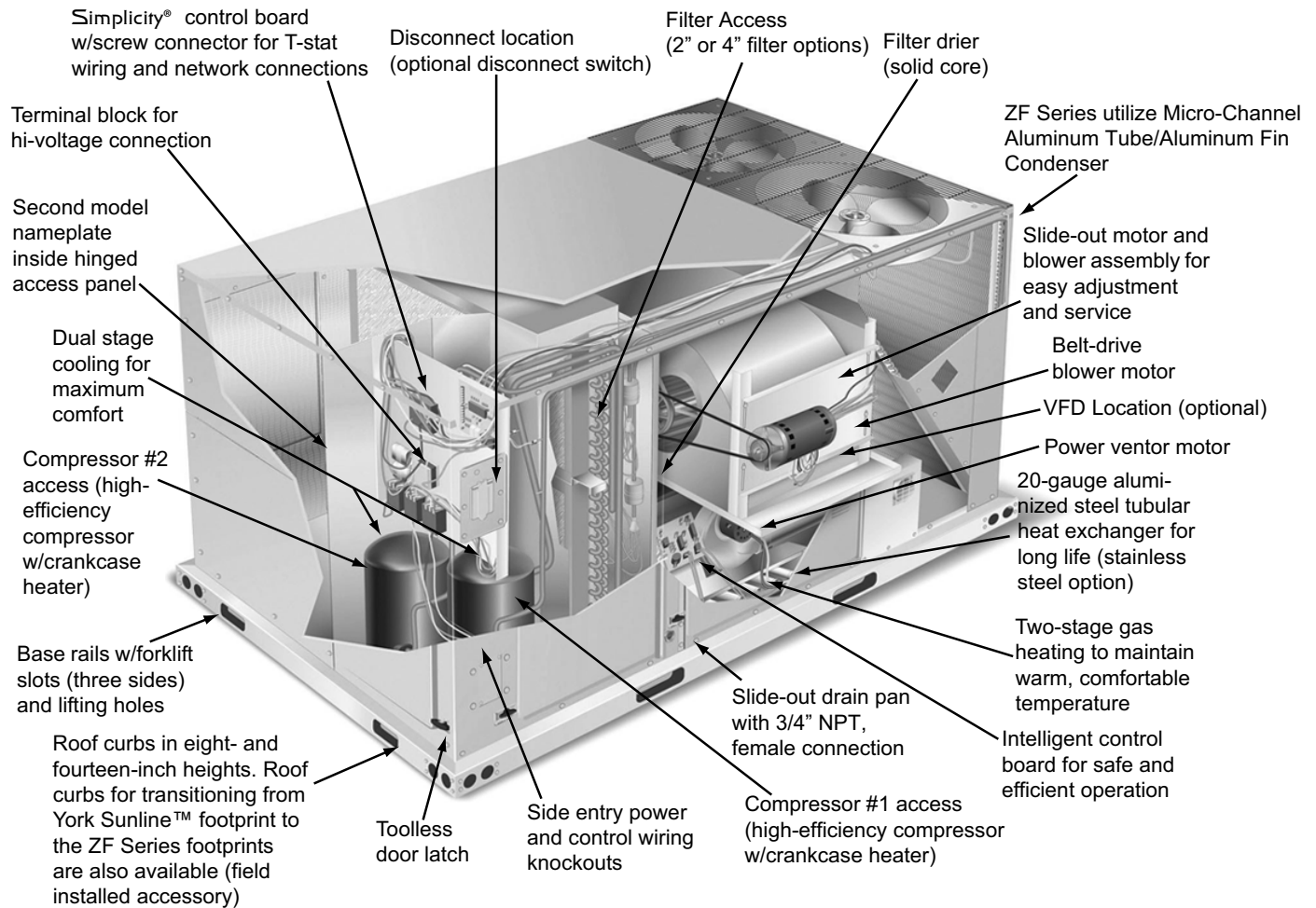

Table of Contents

Description	1
Table of Contents	2
Component Location	2
Nomenclature	3
Features and Benefits	4
Guide Specifications	10
Physical Data	15
Capacity Performance	20
Airflow Performance	50
Sound Performance	63
Electrical Data	64
Typical Wiring Diagrams	80
Weights and Dimensions	95
Economizer Options	106

Component Location

Cooling With Gas Heat



Nomenclature

6.5-12.5 Ton York® Model Number Nomenclature

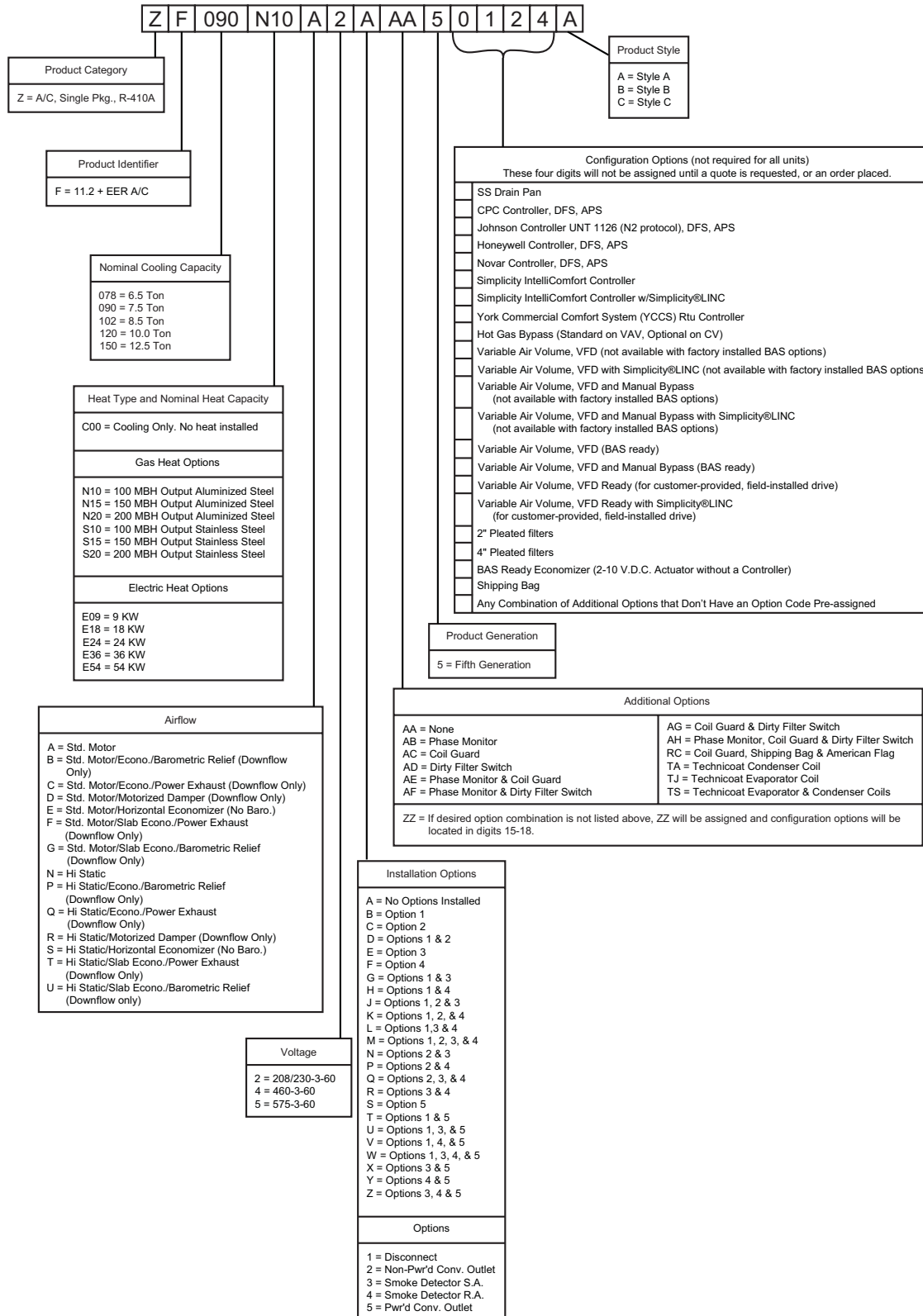

Features and Benefits

Standard Features

- **High Efficiency** – High efficiency units reach as high as 11.2 EER. Gas/electric units have electronic spark ignition and power vented combustion with steady state efficiencies of 80%. These efficiencies exceed all legislated minimum levels and provide low operating costs.

- **Service Friendly** – The Predator[®] incorporates a number of enhancements which improve serviceability.

The motor and blower slide out of the unit as a common assembly. This facilitates greater access to all the indoor airflow components, thus simplifying maintenance and adjustment.

Service time is reduced through the use of hinged, toolless panels. Such panels provide access to frequently inspected components and areas, including the control box, compressors, filters, indoor motor & blower, and the heating section. The panels are screwed in place at the factory to prevent access by children or other unauthorized persons. It is recommended that the panels be secured with screws once service is complete.

Service windows have been placed in both condenser section walls. Rotation of the cover allows easy access to the condenser coils for cleaning or inspection.

Both the unit control board and ignition control board utilize flash codes to aid in diagnosis of unit malfunctions. Unique alarm codes quickly identify the source of the unit alarm.

All units use the same standard filter size. This standardization removes any confusion on which filter sizes are needed for replacement.

The non-corrosive drain pan slides out of the unit to permit easy cleaning. The drain pan is accessed by removing the drain pan cover plate on the rear of the unit. Once the plate is removed, the drain pan slides out through the rear of the unit. All Predator[®] units have a second model nameplate located inside the control access door. This is to prevent deterioration of the nameplate through weathering.

- **Coil Technology** – ZF condensers utilize Micro-Channel “all aluminum” condensers which provide improved heat transfer capabilities and reduced charge volumes.
- **Environmentally Aware** – For improved Indoor Air Quality, a combination of foil faced and elastometric rubber insulation is used exclusively throughout the units.
- **Balanced Heating** – The Predator[®] offers “Ultimate Heating Comfort” with a balance between 1st and 2nd stage gas heating. The first stage of a gas heat Predator[®] unit provides 60% of the heating capacity. Balanced heating allows the unit to better maintain desired temperatures.
- **Convertible Airflow Design** – The side duct openings are covered when they leave the factory. If a side supply/return is desired, the installer simply removes the two side duct covers from the outside of the unit and installs them over the down shot openings. No panel cutting is required. Convertible airflow design allows maximum field flexibility and minimum inventory.

- **System Protection** - Suction line freezestats are supplied on all units to protect against loss of charge and coil frosting when the economizer operates at low outdoor air temperatures while the compressors are running. Every unit has solid-core liquid line filter-driers and high and low-pressure switches. Internal compressor protection is standard on all compressors. Crankcase heaters are standard on reciprocating compressors. Scroll compressors do not require crankcase heaters. Phase Monitors are standard on units with scroll compressors. This accessory monitors the incoming power to the unit and protects the unit from phase loss and reversed phase rotation.
- **Advanced Controls** - Simplicity[®] control boards have standardized a number of features previously available only as options or by utilizing additional controls.
 - **Low Ambient** - An integrated low-ambient control allows all units to operate in the cooling mode down to 0°F outdoor ambient without additional assistance. Optionally, the control board can be programmed to lockout the compressors when the outdoor air temperature is low or when free cooling is available.

CAUTION

The Simplicity[®] control board used in this product will effectively operate the cooling system down to 0°F when this product is applied in a comfort cooling application for people. An economizer is typically included in this type of application. When applying this product for process cooling applications (computer rooms, switchgear, etc.), please reference applications bulletin AE-011-07 or call the applications department for Unitary Products @ 1-877-UPG-SERV for guidance. Additional accessories may be needed for stable operation at temperatures below 30° F.

- **Anti-Short Cycle Protection** - To aid compressor life, an anti-short cycle delay is incorporated into the standard controls. Compressor reliability is further ensured by programmable minimum run times. For testing, the anti-short cycle delay can be temporarily overridden with the push of a button.
- **Fan Delays** - Fan on and fan off delays are fully programmable. Furthermore, the heating and cooling fan delay times are independent of one another. All units are programmed with default values based upon their configuration of cooling and heat.
- **Safety Monitoring** - The control board monitors the high and low-pressure switches, the freezestats, the gas valve, if applicable, and the temperature limit switch on gas and electric heat units. The unit control board will alarm on ignition failures, compressor lockouts and repeated limit switch trips.
- **Nuisance Trip Protection and Strikes** - To prevent nuisance trouble calls, the control board uses a “three times, you’re out” philosophy. The high and low-pres-

sure switches and the freezestats must trip three times within two hours before the unit control board will lock out the associated compressor.

- **On Board Diagnostics** - Each alarm will energize a trouble light on the thermostat, if so equipped, and flash an alarm code on the control board LED. Each high and low-pressure switch alarm as well as each freezestat alarm has its own flash code. The control board saves the five most recent alarms in memory, and these alarms can be reviewed at any time. Alarms and programmed values are retained through the loss of power.
- **Reliable** – From the beginning – All units undergo computer automated testing before they leave the factory. Units are tested for refrigerant charge and pressure, unit amperage, and 100% functionality. For the long term – All Predator® units are painted with a long lasting, powder paint that stands up over the life of the unit. The paint used has been proven by a 1000 hour salt spray test.
- **Flexible Placement** – All models and configurations share the same cabinet/footprint and thus the same roof curb. You have the flexibility to set one curb and choose the correct tonnage size and heating option after the internal loads have been determined.
To further simplify planning and installation, Predator® ZF cabinets are designed to fit your roof. With the optional roof curb, the unit ductwork is designed to fit around 24" on-center joists or between 48" on-center joists.
The drain pan can be rotated to drain to either the front or the rear of the unit. Additionally, the drain pan can be fitted to drain through the roof curb. As it is sometimes difficult to have a level installation, the drain pan features a generous slope to ensure proper drainage.
- **Full Perimeter Base Rails** – The permanently attached base rails provide a solid foundation for the entire unit and protect the unit during shipment. The rails offer forklift access from 3 sides, and rigging holes are available so that an overhead crane can be used to place the units on a roof.
- **Easy Installation** – Gas and electric utility knockouts are supplied in the unit underside as well as the side of the unit. A clearly identified location is provided to mount a field supplied electrical disconnect switch. Utility connections can be made quickly and with a minimum amount of field labor. All units are shipped with 2" throw-away filters installed.
- **Wide Range of Indoor Airflows** – All indoor fan motors are belt-drive type providing maximum flexibility to handle most airflow requirements. For high static applications, factory installed alternate indoor fan motors are available. With the optional indoor fan motor, all units can supply nominal airflow at a minimum of 1.5" ESP.
A variable air volume (VAV) option using a variable frequency drive is available on 6-1/2 through 12-1/2 ton, ZF models for applications requiring a constant supply duct pressure. A differential pressure transducer is used to monitor supply duct static pressure while a VAV control board provides a speed reference signal to the VFD to control the output of the indoor blower motor.

- **Warranty** - All models include a 1-year limited warranty on the complete unit. Compressors and electric heater elements each carry a 5-year warranty. Aluminized steel and stainless steel tubular heat exchangers carry a 10-year warranty.

Factory Installed Options

YORK® offers several equipment options factory installed, for the Predator® line.

- **Optional Factory Installed Economizers** - Predator units offer a variety of optional factory installed economizers with low leak dampers. The outdoor air enthalpy sensor enables economizer operation if the outdoor enthalpy is less than the setpoint of the economizer logic module. See economizer options section to determine the correct economizer for your application.
- **Downflow Economizer - (With barometric relief)** - The economizer is provided with a single enthalpy input. The economizer is 2% low leakage type, and is shipped installed and wired. The installer needs only to assemble and mount the outdoor air hood (Provided). The economizer has spring return, fully modulating damper actuators and is capable of introducing up to 100% outdoor air. As the outdoor air intake dampers open, the return air dampers close. The changeover from mechanical refrigeration to economizer operation is regulated by the standard single enthalpy input. There is an optional input dual dry bulb available. To meet regulated air standards, the economizer control accepts an optional CO₂ input for demand ventilation. With single enthalpy input, the economizer control monitors outdoor air. The dual enthalpy kit provides a second input used to monitor the return air. With a dual input kit installed, the economizer control compares the values of the two enthalpy or temperature inputs and positions the dampers to provide the maximum efficiency possible.
- **Horizontal Economizer - (Without barometric relief)** - All features of the downflow economizer exist except you must order the duct mount barometric relief separately. **You must order a 1EH0408 if you are installing a power exhaust. You can order a 1RD0411 Barometric Relief for horizontal flow economizers only.**
- **BAS Ready Economizer -(With barometric relief)** - The economizer is provided with an actuator that requires a 2-10V DC input from an external source (i.e., field installed building automation system controller). Power exhaust options are available. The economizer is 2% low leakage type with spring return and fully modulating dampers capable of introducing up to 100% outside air. Also include 2" pleated filters. BAS Ready actuators have an adjustable auxiliary end-switch for optional power exhaust control.
For units with optional VAV or Simplicity® Intelli-Comfort™ control, a factory-installed, dry bulb sensor determines if outdoor air temperature is low enough to provide free-cooling operation. (Field-installed humidity sensors for either outdoor air or outdoor & return air streams are available for single enthalpy and differential enthalpy configurations respectively).

• **Slab Economizer for Energy Recovery Ventilators (With barometric relief and Fresh Air Hood)** - The economizer is provided with a single enthalpy input. The economizer is 2% low leakage type, and is shipped installed and wired. The economizer has spring return, fully modulating damper actuators and is capable of introducing up to 100% outdoor air. As the outdoor air intake dampers open, the return air dampers close. The changeover from mechanical refrigeration to economizer operation is regulated by the standard single enthalpy input. There is an optional input dual dry bulb available. To meet regulated air standards, the economizer control accepts an optional CO₂ input for demand ventilation. With single enthalpy input, the economizer control monitors outdoor air. The dual enthalpy kit provides a second input used to monitor the return air. With a dual input kit installed, the economizer control compares the values of the two enthalpy or temperature inputs and positions the dampers to provide the maximum efficiency possible.

- **Power Exhaust (Downflow only)** - This accessory installs in the unit with a down flow economizer.
- **Motorized Outdoor Air Damper** - The motorized outdoor air damper includes a slide-in/plug-in damper assembly with an outdoor air hood and filters. The outdoor air dampers open to the preset position when the indoor fan motor is energized. The damper has a range of 0% to 100% outdoor air entry. Factory installed option or field installed accessory.
- **Alternate Indoor Blower Motor** - For applications with high static restrictions, units are offered with optional indoor motors that provide higher static output and/or higher airflow, depending upon the installer's needs.
- **Variable Air Volume (VAV); 6-1/2 through 12-1/2 ton** - A factory-installed variable frequency drive (VFD), mounted in the Blower Access compartment, is used to control the speed of the indoor blower motor in order to maintain a constant static pressure in the supply duct. A pressure transducer and VAV control board are mounted inside the control box. The drive comes completely wired and preprogrammed from the factory.

An optional, factory-installed manual bypass switch available with factory-installed VFD can be found in the Blower Motor Access compartment. The switch can be used to either route power to the VFD for modulating control of the blower motor, to bypass the drive and operate the motor at full speed, or to power the drive (and not the motor) for diagnostic purposes.

Due to space limitations, VAV is not available with any of the factory-installed BAS options, but is available with 'BAS-ready' models. Terminal blocks are provided in the control box for field wiring of the customer-installed BAS. A 'VFD-ready' option provides the provisions for a customer-installed drive. The unit comes with a mounting bracket installed in the Blower Access compartment which may accommodate other vendor's drives depending on their size. In order to utilize the unit's mounting bracket, the maximum recommended drive dimensions are limited to approximately 9" H x 5" W x 7.5" D.

If the drive will not fit in the allotted space, then it will have to be mounted elsewhere; either within the building on a perpendicular wall which is not subjected to excessive temperature, vibration, humidity, dust, corrosive gas, explosive gas, etc., or within an appropriate enclosure rated for outside installation to safeguard against moisture, dust and excessive heat. A terminal block located in the control box is provided for field connection of the VFD controls.

- **Aluminized Steel Gas Heat Exchanger** - For applications in non-corrosive environments.
- **Stainless Steel Gas Heat Exchanger** - For applications in corrosive environments, this option provides a full stainless steel heat exchanger assembly.
- **Stainless Steel Drain Pan** - An optional rust-proof stainless steel drain pan is available to provide years of trouble-free operation in corrosive environments.
- **Electric Heaters** - The electric heaters range from 9kW to 54kW and are available in all the voltage options of the base units. All heaters are dual staged. All heaters are intended for single point power supply.
- **Disconnect Switch** - For gas heat units and cooling units with electric heat, a HACR breaker sized to the unit is provided. For cooling only units, a switch sized to the largest electric heat available for the particular unit is provided. Factory installed option only.
- **Convenience Outlet - (Non-Powered/Powered)** - This option locates a 120V single-phase GFCI outlet with cover, on the corner of the unit housing adjacent to the compressors. The "Non-powered" option requires the installer to provide the 120V single-phase power source and wiring. The "Powered" option is powered by a stepdown transformer in the unit. Factory installed option only.
- **Smoke Detectors** - The smoke detectors stop operation of the unit by interrupting power to the control board if smoke is detected within the air compartment. Available for both the supply and/or return air configurations.
- **Filters** - 2" Pleated MERV 7 or 4" Pleated MERV 13 are available to meet LEED requirements. A 2" Throwaway is shipped as standard.

▲ WARNING

Factory-installed smoke detectors may be subjected to extreme temperatures during "off" times due to outside air infiltration. These smoke detectors have an operational range of -4 °F to 158°F. Smoke detectors installed in areas that could be outside this range will have to be relocated to prevent false alarms.

- **Phase Monitors** - Designed to prevent unit damage. The phase monitor will shut the unit down in an out-of phase condition. **(Standard on units with Scroll Compressors.)**
- **Coil Guard** - Customers can purchase a coil guard kit to protect the condenser coil from damage. Additionally, this kit stops animals and foreign objects from entering the space between the inner condenser coil and the main cabinet. This is not a hail guard kit.

- **Dirty Filter Switch** - This kit includes a differential pressure switch that energizes the fault light on the unit thermostat, indicating that there is an abnormally high pressure drop across the filters. Factory installed option or field installed accessory.
- **Technicoat Condenser Coils** - The condenser coils are coated with a phenolic coating for protection against corrosion due to harsh environments.
- **Technicoat Evaporator Coil** - The evaporator coils are coated with a phenolic coating for protection against corrosion due to harsh environments.
- **Hot Gas Bypass** - Allows operation during low load conditions while avoiding coil frosting and damage to compressor. When suction pressure falls below valve setpoint, the valve modulates hot gas to the inlet of the evaporator.
HGBP is standard on all units with VAV, and optional with constant-volume units.

Control Options

- **BAS - Building Automation System Controls Simplicity[®] INTELLI-Comfort[™] Control** - The York[®] Simplicity[®] INTELLI-Comfort[™] control is factory installed. It includes a supply air sensor, a return air sensor, and an outside air sensor. There are provisions for a field installed dirty filter indicator switch, an air-proving switch, an Outside Air Humidity sensor, a Return Air Humidity sensor, an Inside IAQ sensor, and an Outside Air IAQ sensor. Construction mode operation, 365-day real time clock with 7 day programming plus holiday scheduling is built-in. Two different modes of demand ventilation are achieved through the INTELLI-Comfort[™] using CO₂ sensors. It uses an inside CO₂ sensor to perform Demand Ventilation. It can also use an Outside CO₂ sensor to perform Differential Demand Ventilation. It uses a Patented Comfort Ventilation algorithm to provide comfortable ventilation air temperature. The patented economizer-loading algorithm will protect the equipment when harsh operating conditions exist. Humidity in the occupied space or return duct can be monitored and controlled via humidity sensors and the on-board connection for hot gas re-heat system. It uses the INTELLI-Start[™] algorithm to maximize energy savings by recovering the building from the Unoccupied Setpoints to the Occupied Setpoints just in time for the Occupied Time Period to begin. The Simplicity[®] INTELLI-Comfort[™] balances space temperature, ventilation air temperature, CO₂ and humidity for ultimate comfort.
- **Simplicity[®] INTELLI-Comfort[™] with Simplicity@LINC Control** - The York[®] Simplicity[®] INTELLI-Comfort[™] with Simplicity@LINC control is factory installed. It includes all the features of the INTELLI-Comfort[™] control with an additional control to translate communications from MODBUS to the BACnet MSTP protocol.
- **Novar[®] BAS Control** - The Novar[®] building automation system controller is factory installed. Includes supply air sensor, return air sensor, dirty filter indicator switch, and air proving switch.
- **Johnson Controls BAS Control** - The Johnson Control YK-UNT-1126 building automation system controller is factory installed. Includes supply air sensor, return air sensor, dirty filter indicator switch, and air proving switch.
- **CPC BAS Control** - The Computer Process Controls Model 810-3060 ARTC Advanced Rooftop building automation system controller is factory installed. Includes supply air sensor, return air sensor, dirty filter indicator switch and air proving switch.
- **Honeywell BAS Control** - The Honeywell W7750C building automation system controller is factory installed. Includes air supply sensor, return air sensor, dirty filter indicator switch, and air proving switch.
- **York Commercial Comfort System (YCCS)** - Provides rooftop system integration for YCCS single zone and change-over bypass systems (Not offered on ZR units.).

Field Installed Accessories

YORK[®] offers several equipment accessories for field installation, for the Predator[®] line.

- **Downflow Economizer - (With barometric relief)** - The economizer is provided with a single enthalpy input. The economizer is 2% low leakage type. The economizer has spring return, fully modulating damper actuators and is capable of introducing up to 100% outdoor air. As the outdoor air intake dampers open, the return air dampers close. The changeover from mechanical refrigeration to economizer operation is regulated by the standard single enthalpy input. There is an optional input dual dry bulb available. To meet regulated air standards, the economizer control accepts an optional CO₂ input for demand ventilation. With single enthalpy input, the economizer control monitors outdoor air. The dual enthalpy kit provides a second input used to monitor the return air. With a dual input kit installed, the economizer control compares the values of the two enthalpy or temperature inputs and positions the dampers to provide the maximum efficiency possible.
- **Horizontal Economizer - (Without barometric relief)** - All features of the downflow economizer exist except you must order the duct mount barometric relief separately. **You must order a 1EH0408 if you are installing a power exhaust. You can order a 1RD0411 Barometric Relief for horizontal flow economizer.**
- **Slab Economizer for Energy Recovery Ventilator - (Without barometric relief or Fresh Air Hood)** - The economizer is provided with a single enthalpy input. The economizer is 2% low leakage type. The economizer has spring return, fully modulating damper actuators and is capable of introducing up to 100% outdoor air. As the outdoor air intake dampers open, the return air dampers close. The changeover from mechanical refrigeration to economizer operation is regulated by the standard single enthalpy input. There is an optional input dual dry bulb available. To meet regulated air standards, the economizer control accepts an optional CO₂ input for demand ventilation. With single enthalpy input, the economizer control monitors outdoor air. The dual enthalpy kit provides a second input used to monitor the return air. With a dual input kit installed, the economizer control compares the values of the two enthalpy or temperature inputs and positions the dampers to provide the maximum efficiency possible.

You can order 1EH0409 Barometric Relief/FA Hood for field installations without an ERV.

- **Dual Enthalpy Control, Accessory** - This kit contains the required components to convert a single enthalpy economizer to dual enthalpy.
- **Barometric Relief Damper** - Zero to 100% capacity barometric relief dampers for use with horizontal flow, or field installed slab economizers.
- **Power Exhaust** - This accessory installs in the unit with a down flow economizer. Power exhaust plugs into the connector in the unit bulkhead. **You must purchase 1EH0408 barometric relief when applying to a horizontal flow application.**
- **Manual Outdoor Air Damper** - Like the motorized outdoor air damper, each manual outdoor air damper includes a slide-in damper assembly with an outdoor air hood and filters. Customers have a choice of dampers with ranges of 0% to 100% or 0% to 35% outdoor air entry.
- **Motorized Outdoor Air Damper** - The motorized outdoor air damper includes a slide-in/plug-in damper assembly with an outdoor air hood and filters. The outdoor air dampers open to the preset position when the indoor fan motor is energized. The damper has a range of 0% to 100% outdoor air entry. Factory installed option or field installed accessory.
- **Smoke Detectors** - The smoke detectors stop operation of the unit by interrupting power to the control board if smoke is detected within the air compartment.
- **CO₂ Sensor** - Senses CO₂ levels and automatically overrides the economizer when levels rise above the preset limits.
- **Dirty Filter Switch** - This kit includes a differential pressure switch that energizes the fault light on the unit thermostat, indicating that there is an abnormally high pressure drop across the filters.
- **Coil Guard** - Field installed decorative wire coil guard.
- **Hail Guard** - This kit includes a sloped hood which installs over the outside condenser coil and prevents damage to the coil fins from hail strikes. Field installed accessory only.
- **Flue Exhaust Extension Kit** - In locations with wind or weather conditions which may interfere with proper exhausting of furnace combustion products, this kit can be installed to prevent the flue exhaust from entering nearby fresh air intakes.
- **-60°F Gas Heat Kit** - For installations which require gas heat units to perform in low ambient temperatures, a gas section heating kit is available. This kit provides electric heat in the gas heat controls section to ensure the gas

valve and controls will continue to function properly at extremely low temperatures.

- **Gas Heat High Altitude Kit** - This kit converts a gas heat unit to operate at high altitudes, 2,000 to 6,000 feet. Conversion kits are available for natural gas and propane.
- **Gas Heat Propane Conversion Kit** - This kit converts a gas-fired heater from natural gas to propane. It contains the main burner orifices and gas valve replacement springs.
- **Gas Piping Kit** - Contains pipe nipples, fittings and gas cock required for gas supply connection with external shut off.
- **Electric Heaters** - The electric heaters range from 9 kW to 54kW and are available in all the voltage options of the base units. The 54kW/208-240 volt, Field-installed heater kit is not available with VAV units due to a lack of space to accommodate the heater's fuse block accessory.
All heaters are dual staged. Cooling units include an adapter panel for easy installation of the electric heaters. Necessary hardware and connectors are included with the heaters. All heaters are intended for single point power supply.
- **Low Limit / Compressor Lockout Kit**
 - **Compressor Lockout (CLO):** To prevent mechanical (compressorized) operation of the unit during cold outdoor conditions where there is a risk of returning liquid refrigerant back to the compressors.
 - **Low Limit Control (LLC):** To prevent the supply air from dropping below a specified setpoint by utilizing the units first stage heating means when there is a demand for cooling during cold outside conditions.
- **Metal Frame Filter Kit** - Metal frame with polyester filter medium.
- **Permanent Filters** - Permanent filters are available.
- **Roof Curbs** - The roof curbs have insulated decks and are shipped disassembled. The roof curbs are available in 8" and 14" heights. For applications with security concerns, burglar bars are available for the duct openings of the roof curbs.
- **Roof Curb Transition** - Single Piece Adapter (10" High) - Roof curbs for transitioning from Sunline™ units to Predator® units. Fits 7.5 to 12.5 Sunline™ roof curbs only.
- **Burglar Bars** - Mount in the supply and return openings to prevent entry into the duct work.
- **Thermostat** - The units are designed to operate with 24-volt electronic and electro-mechanical thermostats. All units (with or without an economizer) operate with two-stage heat/two-stage cool or two-stage cooling only thermostats, depending upon unit configuration.

Accessories

Field Installed Accessories - Non-Electrical

MODEL	VOLTAGE	DESCRIPTION	WHERE USED
1BD0408	All	Burglar Bars, Downflow	All Cabinets
1CG0419	All	Coil Guard	(Electric / Electric Models), 50" Tall Standard Cabinets
1CG0420	All	Coil Guard	(Gas / Electric Models), 50" Tall Standard Cabinets
1CG0427	All	Coil Guard	(Electric / Electric Models), 42" Tall Cabinets
1CG0428	All	Coil Guard	(Gas / Electric Models), 42" Tall Cabinets
1HG0411	All	Hail Guard Kit	All Tall (50") Standard Cabinets, (Excludes 12.5T "V" cabinets)
1HG0415	All	Hail Guard Kit	All Short (42") Standard Cabinets
1FE0411	All	Flue Exhaust Extension Kit	All Cabinets
1FF0414	All	2" only Metal Filter Frame Kit	All Tall 50" Cabinets
1FF0415	All	2" only Metal Filter Frame Kit	All Tall 42" Cabinets
1FL0402	All	Permanent 2" only Filter Kit Includes (4) Four Filters)	All Tall 50" Cabinets
1FL0423	All	Permanent 2" only Filter Kit (Includes (4) four Filters)	All Tall 42" Cabinets
1GP0405	All	Gas Piping Kit	All Cabinets
1HA0442	All	High Altitude Kit for Natural Gas	All 6 - 12T Cabinets
1HA0443	All	High Altitude Kit for Propane	All 6 - 12T Cabinets
1NP0442	All	Propane Conversion Kit	All 6 - 12T Cabinets
1RC0470	All	Roof Curb, 8" Height	All Cabinets
1RC0471	All	Roof Curb, 14" Height	All Cabinets
1RC0472	All	Roof Curb, Transition (7.5 T thru 12.5T Sunline to Predator 3- 12T)	All Cabinets
1WC0412	All	Wooden Crate for extra protection during shipping and handling	Standard Cabinets Only (not applicable to units 119" in length)

Field Installed Accessories - Electric Heat

MODEL	VOLTAGE	DESCRIPTION	WHERE USED
2TP04520925	230	9kW Electric Heat	All 50" Cabinet 6.5 and 8.5 Ton Models
2TP04520946	460		
2TP04520958	575		
2TP04531825	230	18kW Electric Heat	All 50" Cabinet 6.5, 8.5, 10 and 12.5 Ton Models
2TP04531846	460		
2TP04521858	575		
2TP04532425	230	24kW Electric Heat	All 50" Cabinet 6.5, 8.5, 10 and 12.5 Ton Models
2TP04532446	460		
2TP04522458	575		
2TP04533625	230	36kW Electric Heat	All 50" Cabinet 6.5, 8.5, 10 and 12.5 Ton Models
2TP04533646	460		
2TP04523658	575		
2TP04525425	230	54kW Electric Heat	All 50" 10 and 12.5 Ton Models
2TP04525446	460		
2TP04525458	575		
2TP04540925	230	9kW Electric Heat	All 42" Cabinet 6.5, 7.5 and 8.5 Ton Models
2TP04540946	460		
2TP04540958	575		
2TP04541825	230	18kW Electric Heat	All 42" 6.5, 7.5 and 8.5 Ton Models
2TP04541846	460		
2TP04541858	575		
2TP04542425	230	24kW Electric Heat	All 42" Cabinet 6.5, 7.5 and 8.5 Ton Models
2TP04542446	460		
2TP04542458	575		
2TP04543625	230	36kW Electric Heat	All 42" Cabinet 6.5, 7.5 and 8.5 Ton Models
2TP04543646	460		
2TP04543658	575		

Accessories (Continued)**Field Installed Accessories - Fresh Air**

MODEL	VOLTAGE	DESCRIPTION	WHERE USED
1EH0407	All	Barometric Relief Kit for Power Exhaust, Downflow Application (Includes Hood)	All Cabinets
1EH0408	All	Barometric Relief Kit for Power Exhaust, Horizontal Application	All Cabinets
1EH0409	All	Barometric Relief/Hood Kit - Required for field installed slab economizer without ERV	All Cabinets
1FA0413	All	Manual Outside Air Damper 0-35%, Downflow	All Cabinets
1FA0414	All	Manual Outside Air Damper 0-100%, Downflow	All Cabinets
1RD0411	All	Barometric Relief Kit for Horizontal Applications	All Cabinets
2EC04700924	All	Dual Enthalpy Control	All Cabinets
2EE04705724	All	Downflow Economizer, Slab type for ERV, (no Barometric Relief or FA hood)	All 50" Cabinets
2EE04705824	All	Downflow Economizer, Slab type for ERV, (no Barometric Relief or FA hood)	All 42" Cabinets
2EE04705924	All	Downflow Economizer with Barometric Relief	All Cabinets
2EE04706024	All	Horizontal Economizer without Barometric Relief	All Cabinets
2MD04703224	All	Motorized Damper, Downflow without Barometric Relief	All Cabinets
2MD04703724	All	Motorized Damper, Horizontal	All Cabinets
2PE04703225*	230	Power Exhaust 230V Downflow or Horizontal	All Cabinets
2PE04703246*	460	Power Exhaust 460V Downflow or Horizontal	All Cabinets
2PE04703258*	575	Power Exhaust 575V Downflow or Horizontal	All Cabinets

* Must be installed in return Duct on Horizontal Applications and a 1EH0408 is required.

Field Installed Accessories - Controls

MODEL	VOLTAGE	DESCRIPTION	WHERE USED
2AP0401	All	Air Proving Switch	All Units
2AQ04700324	All	CO ₂ Space Accessory	All Units
2AQ04700424	All	CO ₂ Unit Accessory	All Units
2DF0402	All	Dirty Air Switch	All Units
2DH04700024	All	Humidistat	All Units
2SD04700624	All	Smoke Detector for Supply or Return	All Gen 4 or older units with 2" Filter only capable Cabinets
2SD04700824	All	Smoke Detector for Supply	All Gen 5 units with 2" & 4" Filters
2SD04700924	All	Smoke Detector for Return	All Gen 5 units with 2" & 4" Filters
2SD04701024	All	Smoke Detector for Supply and Return	All Gen 5 units with 2" & 4" Filters

Field Installed Accessories - Electrical

MODEL	VOLTAGE	DESCRIPTION	WHERE USED
2BC04700106	230	Gas heat kit, -60°F	All Units
2BC04700151	460	Gas heat kit, -60°F	All Units
2BC04700154	575	Gas heat kit, -60°F	All Units
2LA04704632	All	Low Ambient Kit	All 3 - 10T units (excludes 12.5T "V" cabinets)

Guide Specifications**GENERAL**

Units shall be manufactured by York International Unitary Products in an ISO 9001 certified facility. YORK® Predator® units are convertible single packages with a common footprint cabinet and common roof curb for all 6-1/2 through 12-1/2 ton models. All units have two compressors with independent R-410A refrigeration circuits to provide 2 stages of cooling. The units were designed for light commercial applications and can be easily installed on a roof curb, slab, or frame. All Predator® units are self-contained and assembled on rigid full perimeter base rails allowing for 3-way forklift access and overhead rigging. Every unit is completely charged with R-410A, wired, piped, and tested at the factory to provide a quick and easy field installation. All units are convertible between side and down airflow. Independent economizer designs are used on side and down discharge applications, as well as all tonnage

sizes. Predator® units are available in the following configurations: cooling only, cooling with electric heat, cooling with gas heat, heat pump, and heat pump with electric heat. Electric heaters are available as factory-installed options or field-installed accessories.

DESCRIPTION

Units shall be factory assembled, single package, (Elec/Elec, Gas/Elec), designed for outdoor installation. They shall have built in field convertible duct connections for down discharge supply/return or horizontal discharge supply/return and be available with factory installed options or field installed accessories. The units shall be factory wired, piped and charged with R-410A refrigerant and factory tested prior to shipment. All unit wiring shall be both numbered and color coded. The cooling performance shall be rated in accordance with DOE and ARI test procedures. Units shall be CSA certified to ANSI Z21.47 and UL 1995/CAN/CSA No. 236-M90 standards.

UNIT CABINET

Unit cabinet shall be constructed of galvanized steel with exterior surfaces coated with a non-chalking, powder paint finish, certified at 1000 hour salt spray test per ASTM-B117 standards. Indoor blower sections shall be insulated with up to 1" thick insulation coated on the airside. Either aluminum foil faced or elastometric rubber insulation shall be used in the unit's compartments and be fastened to prevent insulation from entering the air stream. Cabinet doors shall be hinged with toolless access for easy servicing and maintenance. Full perimeter base rails shall be provided to assure reliable transit of equipment, overhead rigging, fork truck access and proper sealing on roof curb applications. Disposable 2" filters shall be furnished as standard and be accessible through hinged access door. Fan performance measuring ports shall be provided on the outside of the cabinet to allow accurate air measurements of evaporator fan performance without removing panels or creating bypass of the coils. Condensate pan shall be slide out design, constructed of a non corrosive material, internally sloped and conforming to ASHRAE 62-B9 standards. Condensate connection shall be a minimum of ¾" I.D. female and be rigid mount connection.

INDOOR (EVAPORATOR) FAN ASSEMBLY

Fan shall be a belt drive assembly and include an adjustable pitch motor pulley. Job site selected brake horsepower shall not exceed the motors nameplate horsepower rating plus the service factor. Units shall be designed to operate within the service factor. Fan wheel shall be double inlet type with forward curve blades, dynamically balanced to operate smoothly throughout the entire range of operation. Airflow design shall be constant volume. Bearings shall be sealed and permanently lubricated for longer life and no maintenance. Entire blower assembly and motor shall be slide out design.

OUTDOOR (CONDENSER) FAN ASSEMBLY

The outdoor fans shall be of the direct drive type, discharge air vertically, have aluminum blades riveted to corrosion resistant steel spider brackets and shall be dynamically balanced for smooth operation. The outdoor fan motors shall have permanently lubricated bearings internally protected against overload conditions and staged independently. A cleaning window shall be provided on two sides of the units for coil cleaning.

REFRIGERANT COMPONENTS

Compressors:

- a. Shall be fully hermetic type, direct drive, internally protected with internal high-pressure relief and over temperature protection. The hermetic motor shall be suction gas cooled and have a voltage range of + or - 10% of the unit nameplate voltage.
- b. Shall have internal spring isolation and sound muffling to minimize vibration and noise, and be externally isolated on a dedicated, independent mounting.

Coils:

- a. Evaporator coils shall have aluminum plate fins mechanically bonded to seamless internally enhanced copper tubes with all joints brazed. Special Phenolic coating shall be available as a factory option.
- b. Evaporator coils shall be of the direct expansion, draw-thru design.
- c. Condenser coils shall have Micro-Channel aluminum tube, aluminum fins.
- d. Condenser coils shall be of the direct expansion, draw-thru design.

Refrigerant Circuit and Refrigerant Safety Components shall include:

- a. Independent fixed-orifice or thermally operated expansion devices.
- b. Solid core filter drier/strainer to eliminate any moisture or foreign matter.
- c. Accessible service gage connections on both suction and discharge lines to charge, evacuate, and measure refrigerant pressure during any necessary servicing or troubleshooting, without losing charge.
- d. The unit shall have two independent refrigerant circuits, equally split in 50% capacity increments.

Unit Controls:

- a. Unit shall be complete with self-contained low-voltage control circuit protected by a resettable circuit breaker on the 24-volt transformer side.
- b. Unit shall incorporate a lockout circuit which provides reset capability at the space thermostat or base unit should any of the following standard safety devices trip and shut off compressor:
 - c. Loss-of-charge/Low-pressure switch.
 - High-pressure switch.
 - Freeze-protection thermostat, evaporator coil. If any of the above safety devices trip, an LED (light-emitting diode) indicator shall flash a diagnostic code that indicates which safety switch has tripped.
 - d. Unit shall incorporate "AUTO RESET" compressor over temperature, over current protection.
- e. Unit shall operate with conventional thermostat designs and have a low voltage terminal strip for easy hook-up.
- f. Unit control board shall have on-board diagnostics and fault code display.
- g. Standard controls shall include anti-short cycle and low voltage protection, and permit cooling operation down to 0 °F.
- h. Control board shall monitor each refrigerant safety switch independently.
- i. Control board shall retain last 5 fault codes in non-volatile memory, which will not be lost in the event of a power loss.

GAS HEATING SECTION (IF EQUIPPED)

Heat exchanger and exhaust system shall be constructed of aluminized steel and shall be designed with induced draft combustion with post purge logic, energy saving direct spark ignition, and redundant main gas valve. The heat exchanger shall be of the tubular type, constructed of T1-40 aluminized steel for corrosion resistance and allowing minimum mixed air entering temperature of 40 °F. Burners shall be of the in-shot type, constructed of aluminum-coated steel. All gas piping shall enter the unit cabinet at a single location, through either the side or bottom, without any field modifications. An integrated control board shall provide timed control of evaporator fan functioning and burner ignition. Heating section shall be provided with the following minimum protection:

- a. Primary and auxiliary high-temperature limit switches.
- b. Induced draft pressure sensor.
- c. Flame roll out switch (manual reset).
- d. Flame proving controls.
- e. All two stage units shall have two independent stages of capacity (60% 1st stage, 100% 2nd stage).

ELECTRIC HEATING SECTION (IF EQUIPPED)

An electric heating section, with nickel chromium elements, shall be provided in a range of 9 thru 54 KW, offering two states of capacity all sizes. The heating section shall have a primary limit control(s) (automatic reset) to prevent the heating element system from operating at an excessive temperature. The Heating Section assembly shall slide out of the unit for easy maintenance and service. Units with Electric Heating Sections shall be wired for a single point power supply with branch circuit fusing (where required).

UNIT OPERATING CHARACTERISTICS

Unit shall be capable of starting and running at 125 °F outdoor temperature, exceeding maximum load criteria of ARI Standard 340/360. The compressor, with standard controls, shall be capable of operation down to 0 °F outdoor temperature. Unit shall be provided with fan time delay to prevent cold air delivery before heat exchanger warms up. (Gas heat only)

ELECTRICAL REQUIREMENTS - All unit power wiring shall enter unit cabinet at a single factory provided location and be capable of side or bottom entry to minimize roof penetrations and avoid unit field modifications. Separate side and bottom openings shall be provided for the control wiring.

STANDARD LIMITED WARRANTIES - Compressor – 5 Years, Heat Exchanger – 10 Years, Elect. Heat Elem. – 5 Years, Parts – 1 Year

FACTORY INSTALLED OPTIONAL OUTDOOR AIR (Shall be made available by either/or):

- **ELECTRONIC ENTHALPY AUTOMATIC ECONOMIZER** – Outdoor and return air dampers that are interlocked and positioned by a fully-modulating, spring-return damper actuator. The maximum leakage rate for the outdoor air

intake dampers shall not exceed 2% when dampers are fully closed and operating against a pressure differential of 0.5 IWG. A unit-mounted potentiometer shall be provided to adjust the outdoor and return air damper assembly to take in outdoor air to meet the minimum ventilation requirement of the conditioned space during normal operation. During economizer operation, a mixed-air temperature control shall modulate the outdoor and return air damper assembly to prevent the supply air temperature from dropping below 55 °F. Changeover from compressor to economizer operation shall be provided by an integral electronic enthalpy control that feeds input into the basic module. The outdoor intake opening shall be covered with a rain hood that matches the exterior of the unit. Water eliminator/filters shall be provided. Simultaneous economizer/compressor operation is also possible. Dampers shall fully close on power loss. Available with barometric relief or power exhaust.

- **MOTORIZED OUTDOOR AIR DAMPERS** – Outdoor and return air dampers that are interlocked and positioned by a 2-position, spring-return damper actuator. The maximum leakage rate for the outdoor air intake dampers shall not exceed 2% when dampers are fully closed and operating against a pressure differential of 0.5 IWG. A unit-mounted potentiometer shall be provided to adjust the outdoor and return air damper assembly to take in the design CFM of outdoor air to meet the ventilation requirements of the conditioned space during normal operation. Whenever the indoor fan motor is energized, the dampers open up to one of two pre-selected positions – regardless of the outdoor air enthalpy. Dampers return to the fully closed position when the indoor fan motor is de-energized. Dampers shall fully close on power loss.

ADDITIONAL FACTORY INSTALLED OPTIONS

- **ALTERNATE INDOOR BLOWER MOTOR** – For applications with high restrictions, units are available with optional indoor blower motors that provide higher static output and/or higher airflow.
- **Variable Air Volume (VAV)** – The VAV option using a variable frequency drive (VFD) shall be available on 6-1/2 through 12-1/2 ton, models for applications requiring a constant supply-duct static pressure. Units equipped for VAV shall be controlled by a duct pressure transducer with a 0 - 5" WC pressure range. The pressure transducer shall provide a 0 - 5 VDC output signal to a VAV control board which, in turn shall provide a 2 - 10 VDC speed reference signal to the VFD. The VAV control board shall operate using factory-installed Supply Air, Return Air and Outside Air Temperature Sensors with a nominal resistance of 10,000 Ohms. Units equipped with VFD's shall have factory-installed manual bypass as an option.
- **CONVENIENCE OUTLET (POWERED/NON-POWERED)** – Unit can be provided with an optional 120VAC GFCI outlet with cover on the corner of the unit housing the compressors.
- **ELECTRIC HEAT** - Electric Heaters range from 9 kW to 54 kW and are available in all the voltage options of the base unit.

- **PHASE MONITOR** - Designed to prevent damage in out-of-phase condition.
- **COIL GUARD** - Designed to prevent condenser coil damage.
- **BAS CONTROLS** - Include supply air sensor, return air sensor, dirty filter indicator and air proving switch.
- **DIRTY FILTER SWITCH** – This kit includes a differential pressure switch that energizes the fault light on the unit thermostat, indicating that there is an abnormally high-pressure drop across the filters.
- **BREAKER** – An HACR breaker can be factory installed on gas heat units or cooling units with electric heat.
- **DISCONNECT SWITCH** - A disconnect can be factory installed on a cooling only units sized for the largest electric heat available.
- **STAINLESS STEEL HEAT EXCHANGER** – For applications in a corrosive environment, this option provides a full stainless steel heat exchanger assembly.
- **SMOKE DETECTOR** – A smoke detector can be factory mounted and wired in the supply and/or return air compartments.

OTHER PRE-ENGINEERED ACCESSORIES AVAILABLE

- **ROOF CURB** - 14" and 8" high, full perimeter knockdown curb, with hinged design for quick assembly.
- **BAROMETRIC RELIEF DAMPER** – (Unit mounted – Downflow, Duct Mounted – Horizontal) – Contains a rain hood, air inlet screen, exhaust damper and mounting hardware. Used to relieve internal air pressure through the unit during economizer operation.
- **PROPANE CONVERSION KIT** – Contains new orifices and gas valve springs to convert from natural to L.P. gas.
- **60°F GAS HEAT KIT** – Provides an electric heat kit for the gas compartment for use in extreme low ambient conditions.
- **ECONOMIZER** (Downflow and Horizontal flow)
- **POWER EXHAUST** – (Unit mount – Downflow, Duct mount – Horizontal flow)
- **DUAL ENTHALPY KIT** - Provides a second input to economizer to monitor return air.

Physical Data

ZF078-150 Physical Data

Component	Models									
	ZF078		ZF090		ZF102		ZF120		ZF150	
Nominal Tonnage	6.5		7.5		8.5		10		12.5	
ARI COOLING PERFORMANCE										
Gross Capacity @ ARI A point (Mbh)	81000		90000		104000		126000		156000	
ARI net capacity (Mbh)	78000		88000		101000		120000		150000	
EER	11.2		11.2		11.2		11.2		11.2	
IEER	13		12.1		12.5		12.5		12.7	
IPLV	12.9		12.1		12.5		12.6		13.06	
Nominal CFM	2600		2500		3000		4000		4100	
System power (KW)	6.95		7.87		8.60		10.70		13.40	
Refrigerant type	R-410A		R-410A		R-410A		R-410A		R-410A	
Refrigerant charge (lb-oz)										
System 1	4-12		4-12		4-14		6-8		7-8	
System 2	4-10		4-10		5-0		6-8		7-8	
ARI HEATING PERFORMANCE										
Heating model	10	15	10	15	10	15	15	20	15	20
Heat input (K Btu)	120	180	120	180	120	180	180	240	180	240
Heat output (K Btu)	96	144	96	144	96	144	144	192	144	192
AFUE %	-	-	-	-	-	-	-	-	-	-
Steady state efficiency (%)	80	80	80	80	80	80	80	80	80	80
No. burners	4	6	4	6	4	6	6	8	6	8
No. stages	2 ¹	2 ¹	2 ¹	2 ¹	2 ¹	2 ¹	2 ¹	2 ¹	2 ¹	2 ¹
Temperature Rise Range (°F)	20-50	35-65	15-45	30-60	10-40	25-55	20-50	35-65	10-40	25-55
Gas Limit Setting (°F)	165	165	165	165	215	195	195	160	195	160
Gas piping connection (in.)	3/4	3/4	3/4	3/4	3/4	3/4	3/4	3/4	3/4	3/4
DIMENSIONS (inches)										
Length	89		89		89		89		119-1/2	
Width	59		59		59		59		59	
Height	42		42		50-3/4		50-3/4		50-3/4	
OPERATING WT. (lbs.)										
	860		880		1020		1060		1253	
COMPRESSORS										
Type	Recip		Recip		Recip		Recip		Scroll	
Quantity	2		2		2		2		2	
Unit Capacity Steps (%)	50 / 100		50 / 100		50 / 100		50 / 100		50 / 100	
CONDENSER COIL DATA										
Face area (Sq. Ft.)	18.5		18.5		18.5		29.0		29.0	
Rows	1		1		1		1		1	
Fins per inch	23		23		23		23		23	
Tube diameter (in./mm)	.71/18		.71/18		.71/18		.71/18		1/25	
Circuitry Type	2-pass Microchannel		2-pass Microchannel		2-pass Microchannel		2-pass Microchannel		2-pass Microchannel	
EVAPORATOR COIL DATA										
Face area (Sq. Ft.)	10.6		10.6		13.2		13.2		13.2	
Rows	3		3		3		4		3	
Fins per inch	15		15		15		15		15	
Tube diameter	0.375		0.375		0.375		0.375		0.375	
Circuitry Type	Intertwined		Intertwined		Intertwined		Intertwined		Intertwined	
Refrigerant control	TXV		TXV		TXV		TXV		TXV	

ZF078-150 Physical Data (Continued)

Component	Models									
	ZF078		ZF090		ZF102		ZF120		ZF150	
Nominal Tonnage	6.5		7.5		8.5		10		12.5	
CONDENSER FAN DATA										
Quantity of Fans	2		2		2		2		4	
Fan diameter (Inch)	24		24		24		24		24	
Type	Prop		Prop		Prop		Prop		Prop	
Drive type	Direct		Direct		Direct		Direct		Direct	
Quantity of motors	2		2		2		2		4	
Motor HP each	1/3		3/4		3/4		3/4		3/4	
No. speeds	1		1		1		1		1	
RPM	850		1110		1110		1110		1110	
Nominal total CFM	6200		7600		8300		9500		13900	
BELT DRIVE EVAP FAN DATA										
Quantity	1		1		1		1		1	
Fan Size (Inch)	12 x 12		12 x 12		15 x 15		15 x 15		15 x 15	
Type	Centrifugal		Centrifugal		Centrifugal		Centrifugal		Centrifugal	
Motor Sheave	1VM50	1VM50	1VM50	1VM50	1VM50	1VM50	1VM50	1VM50	1VM50	1VP56
Blower Sheave	AK74	AK64	AK74	AK61	AK89	AK74	AK84	AK74	AK74	BK77
Belt	A49	A49	A49	A49	A56	A54	A56	A54	A54	BX55
Motor HP each	1-1/2	2	1-1/2	3	2	3	2	3	3	5
RPM	1725	1725	1725	1725	1725	1725	1725	1725	1725	1725
Frame size	56	56	56	56	56	56	56	56	56	184T
FILTERS										
Quantity - Size	4 - (24 x 16 x 2) ^{2,3}		4 - (24 x 16 x 2) ^{2,3}		4 - (24 x 20 x 2) ^{2,3}		4 - (24 x 20 x 2) ^{2,3}		4 - (24 x 20 x 2) ^{2,3}	
	4 - (24 x 16 x 4) ⁴		4 - (24 x 16 x 4) ⁴		4 - (24 x 20 x 4) ⁴		4 - (24 x 20 x 4) ⁴		4 - (24 x 20 x 4) ⁴	

1. 1ST Stage 60% of 2nd Stage
2. 2 In. Throwaway, Standard, MERV (Minimum Efficiency Reporting Value) 3
3. 2 In. Pleated, Optional, MERV 7
4. 4 In. Pleated, Optional, MERV 13

ZF078-150 Unit Limitations

Size (Tons)	Model	Unit Voltage	Unit Limitations		
			Applied Voltage		Outdoor DB Temp
			Min	Max	Max (°F)
078 (6.5)	ZF	208/230-3-60	187	252	125
		460-3-60	432	504	125
		575-3-60	540	630	125
090 (7.5)	ZF	208/230-3-60	187	252	125
		460-3-60	432	504	125
		575-3-60	540	630	125
102 (8.5)	ZF	208/230-3-60	187	252	125
		460-3-60	432	504	125
		575-3-60	540	630	125
120 (10)	ZF	208/230-3-60	187	252	125
		460-3-60	432	504	125
		575-3-60	540	630	125
150 (12.5)	ZF	208/230-3-60	187	252	125
		460-3-60	432	504	125
		575-3-60	540	630	125

ZF078 (6.5 Ton) (Continued)

Air on Evaporator Coil		Temperature of Air on Condenser Coil															
CFM	WB (°F)	Total Capacity ¹ (MBh)	Total Input (kW) ²	Sensible Capacity (MBh)						Total Capacity ¹ (MBh)	Total Input (kW) ²	Sensible Capacity (MBh)					
				Return Dry Bulb (°F)								Return Dry Bulb (°F)					
				90	85	80	75	70	65			90	85	80	75	70	65
				115°F						125°F							
1625	77	75.2	7.3	29.2	26.1	18.9	-	-	-	68.0	7.9	28.3	22.9	16.6	-	-	-
	72	67.9	7.1	43.8	36.6	29.3	22.1	-	-	60.9	7.7	41.0	33.9	26.8	19.6	-	-
	67	60.5	7.0	58.4	47.1	39.8	32.6	25.4	-	53.8	7.5	53.8	44.1	36.9	29.8	22.7	-
	62	56.1	6.8	56.1	56.1	47.7	40.5	33.3	26.0	50.9	7.3	50.9	50.9	43.7	36.6	29.4	22.3
1950	77	77.6	7.3	37.8	29.4	20.9	-	-	-	70.1	7.9	37.5	26.8	18.5	-	-	-
	72	70.0	7.2	49.4	41.0	32.6	24.2	-	-	62.7	7.7	46.5	38.1	29.8	21.5	-	-
	67	62.4	7.0	61.0	52.6	44.2	35.8	27.4	-	55.4	7.5	55.4	49.5	41.2	32.9	24.5	-
	62	57.8	6.9	57.8	57.8	52.9	44.5	36.1	27.7	52.4	7.4	52.4	52.4	48.7	40.4	32.1	23.8
	57	53.2	6.8	53.2	53.2	46.1	37.7	29.2	20.8	45.1	7.2	45.1	45.1	38.3	29.9	21.6	13.3
2275	77	80.0	7.4	46.3	32.6	23.0	-	-	-	72.1	8.0	46.8	30.8	20.4	-	-	-
	72	72.2	7.2	55.0	45.4	35.8	26.2	-	-	64.6	7.8	51.9	42.4	32.9	23.4	-	-
	67	64.3	7.0	63.6	58.2	48.6	39.0	29.4	-	57.0	7.6	57.0	54.9	45.4	35.9	26.4	-
	62	59.6	6.9	59.6	59.6	58.2	48.6	39.0	29.4	53.9	7.4	53.9	53.9	53.8	44.3	34.8	25.3
	57	54.8	6.8	54.8	54.8	50.6	41.0	31.4	21.8	46.4	7.2	46.4	46.4	42.2	32.7	23.2	13.7
2600	77	82.3	7.4	54.9	35.9	25.1	-	-	-	74.2	8.0	56.0	34.7	22.3	-	-	-
	72	74.3	7.2	60.6	49.8	39.0	28.2	-	-	66.4	7.8	57.3	46.7	36.0	25.3	-	-
	67	66.2	7.1	66.2	63.7	52.9	42.1	31.4	-	58.6	7.6	58.6	58.6	49.7	39.0	28.3	-
	62	61.4	7.0	61.4	61.4	63.4	52.6	41.9	31.1	55.5	7.5	55.5	55.5	55.5	48.1	37.4	26.8
	57	56.5	6.9	56.5	56.5	55.2	44.4	33.6	22.8	47.7	7.3	47.7	47.7	46.2	35.6	24.9	14.2
2925	72	75.5	7.3	65.8	53.9	42.0	30.1	-	-	67.4	7.8	62.5	50.7	38.9	27.0	-	-
	67	67.3	7.1	67.3	66.1	57.0	45.1	33.2	-	59.5	7.6	59.5	59.5	53.6	41.8	30.0	-
	62	62.4	7.0	62.4	62.4	63.4	51.5	39.7	27.8	56.3	7.5	56.3	56.3	56.3	46.2	34.4	22.6
	57	57.4	6.9	57.4	57.4	56.8	44.9	33.0	21.1	48.4	7.3	48.4	48.4	47.7	35.9	24.1	12.3
3250	72	76.8	7.3	71.0	58.0	45.0	32.0	-	-	68.5	7.9	67.6	54.7	41.7	28.8	-	-
	67	68.4	7.1	68.4	68.4	61.1	48.1	35.1	-	60.5	7.7	60.5	60.5	57.6	44.6	31.7	-
	62	63.4	7.0	63.4	63.4	63.4	50.4	37.5	24.5	57.2	7.5	57.2	57.2	57.2	44.3	31.3	18.4
	57	58.4	6.9	58.4	58.4	58.4	45.4	32.4	19.4	49.1	7.4	49.1	49.1	49.1	36.2	23.3	10.3

1. These capacities are gross ratings. For net capacity, deduct air blower motor, MBh = 3.415 x kW. Refer to the appropriate Blower Performance Table for the kW of the supply air blower motor.
2. These ratings include the condenser fan motors (total 1 kW) and the compressor motors but not the supply air blower motor.

ZF090 (7.5 Ton)

Air on Evaporator Coil		Temperature of Air on Condenser Coil															
CFM	WB (°F)	Total Capacity ¹ (MBh)	Total Input (kW) ²	Sensible Capacity (MBh)						Total Capacity ¹ (MBh)	Total Input (kW) ²	Sensible Capacity (MBh)					
				Return Dry Bulb (°F)								Return Dry Bulb (°F)					
				90	85	80	75	70	65			90	85	80	75	70	65
				75°F						85°F							
1875	77	119.9	6.0	49.5	41.4	33.3	-	-	-	112.2	6.6	47.2	39.2	31.3	-	-	-
	72	110.5	6.0	63.2	55.1	47.0	38.8	-	-	103.0	6.6	60.2	52.3	44.3	36.4	-	-
	67	101.1	6.0	76.9	68.8	60.7	52.5	44.4	-	93.7	6.6	73.2	65.3	57.3	49.4	41.4	-
	62	91.2	6.1	91.2	82.1	72.7	64.6	56.4	48.3	84.5	6.6	84.5	79.2	68.8	60.8	52.9	44.9
2250	77	123.0	6.0	54.1	45.0	35.8	-	-	-	115.1	6.7	51.8	42.7	33.7	-	-	-
	72	113.3	6.0	68.8	59.7	50.6	41.4	-	-	105.6	6.7	65.8	56.8	47.8	38.8	-	-
	67	103.6	6.1	83.6	74.5	65.3	56.2	47.1	-	96.1	6.6	79.8	70.8	61.8	52.8	43.8	-
	62	93.6	6.1	93.6	87.4	78.3	69.2	60.0	50.9	86.7	6.6	86.7	83.1	74.1	65.1	56.1	47.1
2625	77	126.0	6.1	58.7	48.5	38.4	-	-	-	118.0	6.7	56.3	46.2	36.2	-	-	-
	72	116.1	6.1	74.5	64.3	54.2	44.1	-	-	108.2	6.7	71.4	61.3	51.2	41.2	-	-
	67	106.2	6.1	90.3	80.1	70.0	59.9	49.7	-	98.5	6.7	86.4	76.4	66.3	56.2	46.1	-
	62	95.9	6.1	95.9	92.8	83.9	73.8	63.7	53.5	88.8	6.6	88.8	87.1	79.5	69.4	59.3	49.3
3000	77	129.1	6.1	63.2	52.1	41.0	-	-	-	120.8	6.8	60.9	49.7	38.6	-	-	-
	72	118.9	6.1	80.1	69.0	57.8	46.7	-	-	110.9	6.7	76.9	65.8	54.7	43.5	-	-
	67	108.8	6.1	97.0	85.8	74.7	63.6	52.4	-	100.9	6.7	93.0	81.9	70.7	59.6	48.5	-
	62	98.2	6.1	98.2	98.2	89.5	78.4	67.3	56.1	91.0	6.7	91.0	91.0	84.8	73.7	62.6	51.4
3375	77	122.5	6.1	85.8	73.6	61.4	49.3	-	-	114.0	6.7	82.8	70.6	58.4	46.2	-	-
	72	112.0	6.1	106.1	91.5	79.4	67.2	55.0	-	103.7	6.7	99.8	87.8	75.6	63.4	51.2	-
	67	101.1	6.1	101.1	101.1	96.8	84.6	72.5	60.3	93.5	6.7	93.5	93.5	90.5	78.3	66.1	53.9
	62	102.8	6.0	102.8	102.8	101.6	89.4	77.3	65.1	95.3	6.6	95.3	95.3	94.4	82.2	70.0	57.9
3750	72	126.1	6.1	91.5	78.3	65.1	51.9	-	-	117.1	6.7	88.7	75.5	62.2	48.9	-	-
	67	115.3	6.1	115.3	97.3	84.1	70.9	57.6	-	106.5	6.7	106.5	93.7	80.5	67.2	53.9	-
	62	104.1	6.1	104.1	104.1	104.1	90.9	77.7	64.5	96.1	6.7	96.1	96.1	96.1	82.8	69.6	56.3
	57	105.8	6.0	105.8	105.8	105.8	92.6	79.4	66.1	97.9	6.6	97.9	97.9	97.9	84.6	71.4	58.1
				95°F						105°F							
1875	77	104.6	7.3	44.9	37.1	29.3	-	-	-	95.9	7.9	40.1	33.5	25.7	-	-	-
	72	95.4	7.2	57.2	49.5	41.7	33.9	-	-	87.2	7.8	53.9	46.1	38.2	30.4	-	-
	67	86.3	7.1	69.6	61.8	54.0	46.3	38.5	-	78.5	7.6	67.7	58.6	50.8	43.0	35.1	-
	62	77.8	7.0	77.8	76.3	64.8	57.1	49.3	41.5	71.0	7.5	71.0	70.3	60.2	52.3	44.5	36.7
2250	77	107.2	7.3	49.4	40.5	31.6	-	-	-	98.3	8.0	45.5	36.7	27.8	-	-	-
	72	97.9	7.3	62.8	53.9	45.0	36.1	-	-	89.4	7.8	59.1	50.2	41.4	32.5	-	-
	67	88.6	7.2	76.1	67.2	58.3	49.4	40.5	-	80.5	7.7	72.7	63.8	54.9	46.1	37.2	-
	62	79.8	7.1	79.8	78.8	69.9	61.0	52.2	43.3	72.8	7.6	72.8	72.3	65.1	56.2	47.3	38.5
2625	77	109.9	7.4	54.0	44.0	34.0	-	-	-	100.8	8.0	50.9	39.8	29.9	-	-	-
	72	100.4	7.3	68.3	58.3	48.2	38.2	-	-	91.6	7.9	64.3	54.4	44.5	34.6	-	-
	67	90.8	7.2	82.6	72.6	62.5	52.5	42.5	-	82.5	7.8	77.6	69.0	59.1	49.2	39.3	-
	62	81.8	7.1	81.8	81.3	75.0	65.0	55.0	45.0	74.6	7.6	74.6	74.3	70.0	60.1	50.2	40.3
3000	77	112.6	7.4	58.5	47.4	36.3	-	-	-	103.2	8.1	56.3	42.9	32.0	-	-	-
	72	102.8	7.4	73.8	62.7	51.5	40.4	-	-	93.9	7.9	69.4	58.5	47.6	36.7	-	-
	67	93.0	7.3	89.1	77.9	66.8	55.7	44.5	-	84.5	7.8	82.5	74.1	63.2	52.3	41.4	-
	62	83.8	7.2	83.8	83.8	80.2	69.0	57.9	46.8	76.4	7.7	76.4	76.4	74.9	64.0	53.0	42.1
3375	77	105.4	7.4	79.9	67.6	55.4	43.2	-	-	96.0	8.0	75.0	63.0	51.0	39.1	-	-
	72	95.4	7.3	93.4	84.1	71.8	59.6	47.4	-	86.5	7.8	85.5	79.4	67.8	55.8	43.9	-
	67	86.0	7.2	86.0	86.0	84.1	71.9	59.7	47.4	78.2	7.7	78.2	78.2	77.4	65.4	53.5	41.5
	62	87.9	7.2	87.9	87.9	87.3	75.0	62.8	50.6	80.5	7.7	80.5	80.5	79.9	67.9	55.9	43.9
3750	72	108.1	7.4	86.0	72.6	59.3	46.0	-	-	98.2	8.0	80.6	67.5	54.5	41.5	-	-
	67	97.8	7.3	97.8	90.2	76.9	63.5	50.2	-	88.4	7.9	88.4	84.6	72.4	59.4	46.3	-
	62	88.1	7.2	88.1	88.1	88.1	74.8	61.4	48.1	79.9	7.7	79.9	79.9	79.9	66.9	53.9	40.9
	57	90.1	7.2	90.1	90.1	90.1	76.7	63.4	50.1	82.4	7.7	82.4	82.4	82.4	69.4	56.3	43.3

ZF090 (7.5 Ton) (Continued)

Air on Evaporator Coil		Temperature of Air on Condenser Coil															
		Total Capacity ¹ (MBh)	Total Input (kW) ²	Sensible Capacity (MBh)						Total Capacity ¹ (MBh)	Total Input (kW) ²	Sensible Capacity (MBh)					
				Return Dry Bulb (°F)								Return Dry Bulb (°F)					
				90	85	80	75	70	65			90	85	80	75	70	65
		115°F								125°F							
1875	77	87.3	8.6	35.4	30.0	22.1	-	-	-	78.6	9.2	31.6	26.4	18.5	-	-	-
	72	79.0	8.4	50.6	42.7	34.8	26.9	-	-	70.8	8.9	47.3	39.3	31.4	23.4	-	-
	67	70.7	8.1	65.8	55.4	47.5	39.6	31.7	-	62.9	8.6	62.9	52.3	44.3	36.3	28.4	-
	62	64.2	8.0	64.2	64.2	55.5	47.6	39.7	31.8	57.4	8.5	57.4	57.4	50.8	42.9	34.9	27.0
2250	77	89.5	8.6	41.6	32.8	24.0	-	-	-	80.6	9.3	39.1	28.9	20.1	-	-	-
	72	81.0	8.4	55.4	46.6	37.8	28.9	-	-	72.5	9.0	51.8	43.0	34.2	25.4	-	-
	67	72.5	8.2	69.2	60.4	51.6	42.7	33.9	-	64.5	8.7	64.5	57.0	48.2	39.4	30.6	-
	62	65.8	8.1	65.8	65.8	60.2	51.4	42.5	33.7	58.7	8.5	58.7	58.7	55.3	46.5	37.7	28.9
	57	68.5	8.0	68.5	68.5	60.7	51.9	43.0	34.2	61.9	8.5	61.9	61.9	54.2	45.4	36.6	27.7
2625	77	91.6	8.7	47.9	35.6	25.8	-	-	-	82.5	9.3	46.5	31.4	21.8	-	-	-
	72	82.9	8.5	60.2	50.5	40.7	30.9	-	-	74.2	9.1	56.2	46.6	36.9	27.3	-	-
	67	74.3	8.3	72.6	65.4	55.6	45.8	36.0	-	66.0	8.8	66.0	61.8	52.1	42.5	32.8	-
	62	67.4	8.1	67.4	67.4	64.9	55.1	45.4	35.6	60.1	8.6	60.1	60.1	59.8	50.2	40.5	30.9
	57	70.1	8.1	70.1	70.1	65.4	55.7	45.9	36.1	63.4	8.6	63.4	63.4	58.6	48.9	39.3	29.6
3000	77	93.8	8.7	54.1	38.4	27.7	-	-	-	84.4	9.4	53.9	33.9	23.4	-	-	-
	72	84.9	8.5	65.1	54.4	43.7	32.9	-	-	75.9	9.1	60.7	50.2	39.7	29.2	-	-
	67	76.0	8.3	76.0	70.3	59.6	48.9	38.2	-	67.5	8.9	67.5	66.5	56.0	45.5	35.0	-
	62	68.9	8.2	68.9	68.9	69.6	58.9	48.2	37.5	61.5	8.7	61.5	61.5	61.5	53.8	43.3	32.8
	57	71.8	8.2	71.8	71.8	70.2	59.5	48.7	38.0	64.8	8.7	64.8	64.8	63.0	52.5	42.0	31.5
3375	72	86.6	8.6	70.1	58.4	46.7	35.0	-	-	77.2	9.2	65.2	53.8	42.3	30.9	-	-
	67	77.6	8.4	77.6	74.7	63.8	52.0	40.3	-	68.6	8.9	68.6	68.6	59.7	48.3	36.8	-
	62	70.3	8.2	70.3	70.3	70.7	59.0	47.2	35.5	62.5	8.7	62.5	62.5	62.5	52.5	41.0	29.6
	57	73.2	8.2	73.2	73.2	72.4	60.7	49.0	37.3	65.9	8.7	65.9	65.9	65.0	53.5	42.1	30.6
3750	72	88.3	8.6	75.2	62.4	49.7	37.0	-	-	78.5	9.2	69.8	57.3	44.9	32.5	-	-
	67	79.1	8.4	79.1	79.1	67.9	55.2	42.4	-	69.8	8.9	69.8	69.8	63.4	51.0	38.6	-
	62	71.7	8.2	71.7	71.7	71.7	59.0	46.3	33.6	63.6	8.8	63.6	63.6	63.6	51.2	38.7	26.3
	57	74.7	8.2	74.7	74.7	74.7	62.0	49.3	36.5	67.0	8.8	67.0	67.0	67.0	54.6	42.2	29.8

1. These capacities are gross ratings. For net capacity, deduct air blower motor, MBh = 3.415 x kW. Refer to the appropriate Blower Performance Table for the kW of the supply air blower motor.
2. These ratings include the condenser fan motors (total 1 kW) and the compressor motors but not the supply air blower motor.

ZF102 (8.5 Ton) (Continued)

Air on Evaporator Coil		Temperature of Air on Condenser Coil															
CFM	WB (°F)	Total Capacity ¹ (MBh)	Total Input (kW) ²	Sensible Capacity (MBh)						Total Capacity ¹ (MBh)	Total Input (kW) ²	Sensible Capacity (MBh)					
				Return Dry Bulb (°F)								Return Dry Bulb (°F)					
				90	85	80	75	70	65			90	85	80	75	70	65
				115°F						125°F							
2125	77	98.1	9.8	38.6	35.3	26.2	-	-	-	89.4	10.5	38.9	30.9	23.7	-	-	-
	72	88.7	9.5	57.8	48.7	39.5	30.4	-	-	80.2	10.1	54.9	45.8	36.7	27.6	-	-
	67	79.2	9.2	77.0	62.0	52.8	43.7	34.6	-	70.9	9.7	70.9	58.8	49.7	40.6	31.4	-
	62	75.1	9.0	75.1	75.1	62.5	53.4	44.2	35.1	68.8	9.6	68.8	68.8	57.6	48.4	39.3	30.2
2550	77	101.4	9.9	50.6	39.9	29.2	-	-	-	91.9	10.6	51.5	37.0	26.4	-	-	-
	72	91.6	9.6	65.5	54.7	44.0	33.3	-	-	82.4	10.2	62.2	51.5	40.9	30.2	-	-
	67	81.8	9.3	80.3	69.6	58.9	48.2	37.5	-	72.9	9.8	72.9	66.1	55.4	44.8	34.1	-
	62	77.6	9.1	77.6	77.6	69.7	59.0	48.3	37.6	70.7	9.7	70.7	70.7	64.2	53.5	42.9	32.2
	57	78.2	9.1	78.2	78.2	67.7	57.0	46.3	35.6	71.3	9.7	71.3	71.3	61.4	50.7	40.1	29.4
2975	77	104.6	10.0	62.6	44.5	32.2	-	-	-	94.4	10.7	64.1	43.2	29.1	-	-	-
	72	94.5	9.7	73.1	60.8	48.6	36.3	-	-	84.6	10.3	69.5	57.3	45.1	32.9	-	-
	67	84.4	9.4	83.6	77.2	64.9	52.7	40.4	-	74.8	9.9	74.8	73.3	61.1	48.9	36.8	-
	62	80.0	9.2	80.0	80.0	76.8	64.6	52.3	40.0	72.6	9.8	72.6	72.6	70.8	58.6	46.4	34.3
	57	80.7	9.2	80.7	80.7	74.7	62.4	50.2	37.9	73.3	9.8	73.3	73.3	67.7	55.6	43.4	31.2
3400	77	107.8	10.1	74.5	49.0	35.2	-	-	-	96.8	10.8	76.7	49.3	31.8	-	-	-
	72	97.4	9.8	80.8	66.9	53.1	39.3	-	-	86.8	10.4	76.7	63.0	49.3	35.6	-	-
	67	87.0	9.5	87.0	84.8	71.0	57.2	43.3	-	76.7	10.1	76.7	76.7	66.8	53.1	39.4	-
	62	82.5	9.3	82.5	82.5	84.0	70.2	56.3	42.5	74.5	9.9	74.5	74.5	74.5	63.7	50.0	36.3
	57	83.2	9.3	83.2	83.2	81.6	67.8	54.0	40.2	75.2	9.9	75.2	75.2	74.1	60.4	46.7	33.0
3825	72	95.3	9.8	86.8	71.6	56.5	41.4	-	-	83.9	10.5	82.5	67.6	52.6	37.6	-	-
	67	85.1	9.5	85.1	84.0	75.6	60.5	45.3	-	74.1	10.1	74.1	74.1	71.2	56.2	41.2	-
	62	80.7	9.3	80.7	80.7	81.5	66.3	51.2	36.1	72.1	10.0	72.1	72.1	72.1	58.5	43.5	28.5
	57	81.4	9.4	81.4	81.4	80.6	65.5	50.4	35.3	72.7	10.0	72.7	72.7	72.1	57.1	42.1	27.2
4250	72	93.2	9.9	92.7	76.3	59.9	43.5	-	-	81.0	10.6	81.0	72.1	55.8	39.6	-	-
	67	83.2	9.6	83.2	83.2	80.2	63.8	47.4	-	71.5	10.2	71.5	71.5	71.5	59.3	43.1	-
	62	78.9	9.4	78.9	78.9	78.9	62.5	46.1	29.7	69.6	10.0	69.6	69.6	69.6	53.3	37.0	20.8
	57	79.6	9.4	79.6	79.6	79.6	63.2	46.8	30.4	70.2	10.1	70.2	70.2	70.2	53.9	37.6	21.4

1. These capacities are gross ratings. For net capacity, deduct air blower motor, MBh = 3.415 x kW. Refer to the appropriate Blower Performance Table for the kW of the supply air blower motor.
2. These ratings include the condenser fan motors (total 1 kW) and the compressor motors but not the supply air blower motor.

ZF120 (10 Ton) (Continued)

Air on Evaporator Coil		Temperature of Air on Condenser Coil															
CFM	WB (°F)	Total Capacity ¹ (MBh)	Total Input (kW) ²	Sensible Capacity (MBh)						Total Capacity ¹ (MBh)	Total Input (kW) ²	Sensible Capacity (MBh)					
				Return Dry Bulb (°F)								Return Dry Bulb (°F)					
				90	85	80	75	70	65			90	85	80	75	70	65
				115°F						125°F							
2500	77	117.2	11.2	54.3	43.9	33.2	-	-	-	104.6	12.1	64.4	42.9	31.5	-	-	-
	72	106.1	10.8	74.7	63.9	53.2	42.5	-	-	94.9	11.6	74.8	64.0	53.3	42.6	-	-
	67	95.0	10.4	95.0	84.0	73.3	62.6	51.8	-	85.2	11.1	85.2	85.2	75.2	64.5	53.8	-
	62	85.5	10.1	85.5	85.5	81.6	70.9	60.1	49.4	76.3	10.8	76.3	76.3	76.3	70.2	59.4	48.7
3000	77	120.1	11.2	64.1	47.2	34.5	-	-	-	106.6	12.3	71.1	45.8	31.5	-	-	-
	72	108.7	10.9	80.7	68.1	55.4	42.7	-	-	96.7	11.7	78.9	66.3	53.7	41.0	-	-
	67	97.4	10.5	97.4	88.9	76.3	63.6	51.0	-	86.8	11.2	86.8	86.8	75.9	63.2	50.6	-
	62	87.5	10.2	87.5	87.5	87.5	74.9	62.2	49.6	77.7	10.9	77.7	77.7	77.7	72.6	60.0	47.3
	57	90.8	10.3	90.8	90.8	87.8	75.2	62.5	49.8	83.7	11.0	83.7	83.7	83.7	72.1	59.4	46.8
3500	77	122.9	11.3	73.9	50.5	35.9	-	-	-	108.6	12.4	77.9	48.7	31.5	-	-	-
	72	111.3	10.9	86.8	72.2	57.6	43.0	-	-	98.5	11.8	83.1	68.6	54.0	39.4	-	-
	67	99.7	10.6	99.7	93.9	79.3	64.7	50.1	-	88.4	11.3	88.4	88.4	76.5	62.0	47.4	-
	62	89.6	10.3	89.6	89.6	93.5	78.9	64.3	49.7	79.2	11.0	79.2	79.2	79.2	75.0	60.5	45.9
	57	93.0	10.4	93.0	93.0	91.3	76.7	62.1	47.5	85.3	11.1	85.3	85.3	85.2	70.6	56.1	41.5
4000	77	125.8	11.4	83.7	53.8	37.2	-	-	-	110.6	12.5	84.6	51.6	31.5	-	-	-
	72	113.9	11.0	92.9	76.3	59.8	43.2	-	-	100.3	11.9	87.3	70.8	54.3	37.8	-	-
	67	102.0	10.6	102.0	98.8	82.3	65.7	49.2	-	90.0	11.4	90.0	90.0	77.2	60.7	44.2	-
	62	91.7	10.4	91.7	91.7	99.5	82.9	66.4	49.8	80.6	11.1	80.6	80.6	80.6	77.4	61.0	44.5
	57	95.1	10.5	95.1	95.1	94.7	78.2	61.6	45.1	86.9	11.2	86.9	86.9	85.7	69.2	52.7	36.2
4500	72	115.9	11.1	99.2	81.4	63.6	45.8	-	-	102.2	12.0	93.1	75.4	57.7	40.1	-	-
	67	103.8	10.7	103.8	102.2	87.6	69.8	52.0	-	91.7	11.5	91.7	91.7	82.0	64.4	46.7	-
	62	93.3	10.4	93.3	93.3	97.2	79.4	61.6	43.8	82.2	11.1	82.2	82.2	82.2	71.2	53.5	35.8
	57	96.8	10.5	96.8	96.8	96.6	78.8	61.0	43.2	88.5	11.3	88.5	88.5	87.9	70.3	52.6	34.9
5000	72	117.9	11.1	105.5	86.5	67.4	48.4	-	-	104.2	12.1	98.9	80.0	61.2	42.3	-	-
	67	105.6	10.7	105.6	105.6	92.8	73.8	54.7	-	93.5	11.5	93.5	93.5	86.9	68.0	49.2	-
	62	95.0	10.5	95.0	95.0	95.0	75.9	56.8	37.8	83.7	11.2	83.7	83.7	83.7	64.9	46.0	27.2
	57	98.5	10.6	98.5	98.5	98.5	79.4	60.4	41.3	90.2	11.3	90.2	90.2	90.2	71.4	52.5	33.7

1. These capacities are gross ratings. For net capacity, deduct air blower motor, MBh = 3.415 x kW. Refer to the appropriate Blower Performance Table for the kW of the supply air blower motor.
2. These ratings include the condenser fan motors (total 1 kW) and the compressor motors but not the supply air blower motor.

ZF150 (12.5 Ton)

Air on Evaporator Coil		Temperature of Air on Condenser Coil															
CFM	WB (°F)	Total Capacity ¹ (MBh)	Total Input (kW) ²	Sensible Capacity (MBh)						Total Capacity ¹ (MBh)	Total Input (kW) ²	Sensible Capacity (MBh)					
				Return Dry Bulb (°F)								Return Dry Bulb (°F)					
				90	85	80	75	70	65			90	85	80	75	70	65
				75°F						85°F							
3125	77	192.8	10.1	75.6	62.8	49.9	-	-	-	185.3	11.1	73.4	60.7	48.0	-	-	-
	72	179.7	9.8	99.3	86.4	73.5	60.6	-	-	171.3	10.9	96.2	83.5	70.8	58.1	-	-
	67	166.6	9.6	122.9	110.0	97.1	84.3	71.4	-	157.2	10.7	119.1	106.4	93.6	80.9	68.2	-
	62	150.6	9.5	150.6	133.0	119.1	106.2	93.3	80.4	142.2	10.6	142.2	132.0	115.5	102.8	90.1	77.4
3750	77	200.7	10.1	83.8	69.2	54.6	-	-	-	192.2	11.1	81.3	66.8	52.4	-	-	-
	72	187.1	9.9	109.7	95.1	80.5	66.0	-	-	177.6	10.9	106.2	91.8	77.4	63.0	-	-
	67	173.4	9.6	135.6	121.0	106.5	91.9	77.3	-	163.0	10.8	131.2	116.8	102.4	88.0	73.5	-
	62	156.8	9.5	156.8	145.1	130.5	115.9	101.3	86.7	147.5	10.6	147.5	140.7	126.3	111.9	97.4	83.0
57	152.3	9.5	152.3	152.3	138.3	123.7	109.1	94.5	144.4	10.6	144.4	144.4	132.5	118.1	103.7	89.3	
4375	77	208.7	10.1	92.0	75.7	59.4	-	-	-	199.1	11.2	89.2	73.0	56.9	-	-	-
	72	194.5	9.9	120.2	103.9	87.6	71.3	-	-	184.0	11.0	116.3	100.1	84.0	67.9	-	-
	67	180.2	9.7	148.3	132.1	115.8	99.5	83.2	-	168.9	10.8	143.4	127.2	111.1	95.0	78.8	-
	62	163.0	9.6	163.0	157.1	141.9	125.6	109.3	93.0	152.8	10.7	152.8	149.4	137.0	120.9	104.8	88.6
57	158.3	9.5	158.3	158.3	150.4	134.1	117.8	101.5	149.5	10.6	149.5	149.5	143.9	127.7	111.6	95.4	
5000	77	216.6	10.1	100.2	82.2	64.2	-	-	-	206.0	11.2	97.1	79.2	61.4	-	-	-
	72	201.8	9.9	130.6	112.6	94.6	76.7	-	-	190.3	11.0	126.3	108.5	90.6	72.8	-	-
	67	187.1	9.7	161.1	143.1	125.1	107.1	89.1	-	174.7	10.8	155.5	137.7	119.8	102.0	84.1	-
	62	169.2	9.6	169.2	169.2	153.3	135.3	117.3	99.3	158.1	10.7	158.1	158.1	147.8	130.0	112.1	94.3
57	164.3	9.6	164.3	164.3	162.5	144.5	126.5	108.5	154.7	10.7	154.7	154.7	155.2	137.3	119.5	101.6	
5625	72	203.6	9.9	138.4	119.4	100.5	81.5	-	-	193.2	11.1	134.4	115.4	96.4	77.5	-	-
	67	188.7	9.7	171.4	151.7	132.8	113.8	94.8	-	177.3	10.9	165.5	146.5	127.6	108.6	89.6	-
	62	170.7	9.6	170.7	170.7	162.7	143.8	124.8	105.8	160.4	10.8	160.4	160.4	155.3	136.3	117.3	98.3
	57	165.7	9.6	165.7	165.7	164.8	145.8	126.9	107.9	157.0	10.7	157.0	157.0	157.2	138.2	119.2	100.3
6250	72	205.4	10.0	146.2	126.2	106.3	86.3	-	-	196.0	11.1	142.5	122.4	102.3	82.1	-	-
	67	190.4	9.8	181.6	160.4	140.4	120.5	100.5	-	179.9	10.9	175.5	155.4	135.3	115.1	95.0	-
	62	172.2	9.7	172.2	172.2	172.2	152.2	132.2	112.3	162.8	10.8	162.8	162.8	162.8	142.7	122.5	102.4
	57	167.2	9.7	167.2	167.2	167.2	147.2	127.2	107.3	159.3	10.8	159.3	159.3	159.3	139.2	119.0	98.9
				95°F						105°F							
3125	77	177.9	12.1	71.1	58.6	46.0	-	-	-	165.4	13.5	65.9	53.7	41.2	-	-	-
	72	162.8	12.0	93.2	80.6	68.1	55.6	-	-	151.1	13.4	88.4	75.9	63.4	51.0	-	-
	67	147.8	11.8	115.2	102.7	90.1	77.6	65.1	-	136.8	13.3	111.0	98.2	85.7	73.2	60.7	-
	62	133.8	11.7	133.8	131.0	111.9	99.4	86.9	74.3	125.4	13.1	125.4	124.0	106.1	93.6	81.1	68.6
3750	77	183.7	12.2	78.7	64.5	50.2	-	-	-	170.9	13.5	73.4	59.2	45.1	-	-	-
	72	168.2	12.0	102.8	88.5	74.3	60.0	-	-	156.1	13.4	97.7	83.6	69.4	55.3	-	-
	67	152.6	11.9	126.8	112.6	98.3	84.0	69.8	-	141.4	13.3	122.1	107.9	93.8	79.6	65.5	-
	62	138.2	11.7	138.2	136.3	122.1	107.8	93.5	79.3	129.6	13.1	129.6	128.7	116.1	102.0	87.8	73.7
57	136.4	11.7	136.4	136.4	126.8	112.5	98.3	84.0	127.8	13.1	127.8	127.8	118.7	104.6	90.4	76.3	
4375	77	189.6	12.2	86.3	70.3	54.4	-	-	-	176.4	13.6	80.9	64.8	49.0	-	-	-
	72	173.5	12.1	112.4	96.4	80.4	64.4	-	-	161.2	13.5	107.0	91.2	75.4	59.6	-	-
	67	157.5	11.9	138.4	122.4	106.5	90.5	74.5	-	145.9	13.3	133.2	117.7	101.9	86.1	70.3	-
	62	142.6	11.8	142.6	141.7	132.2	116.2	100.2	84.2	133.8	13.2	133.8	133.3	126.2	110.4	94.6	78.8
57	140.7	11.8	140.7	140.7	137.3	121.3	105.4	89.4	131.9	13.2	131.9	131.9	129.0	113.2	97.4	81.6	
5000	77	195.4	12.3	93.9	76.2	58.5	-	-	-	181.9	13.6	88.4	70.3	52.9	-	-	-
	72	178.9	12.1	122.0	104.3	86.6	68.9	-	-	166.2	13.5	116.3	98.9	81.4	64.0	-	-
	67	162.3	12.0	150.0	132.3	114.6	96.9	79.2	-	150.5	13.4	144.3	127.5	110.0	92.5	75.1	-
	62	147.0	11.8	147.0	147.0	142.3	124.6	106.9	89.2	138.0	13.2	138.0	138.0	136.2	118.7	101.3	83.8
57	145.1	11.8	145.1	145.1	147.8	130.1	112.4	94.7	136.0	13.2	136.0	136.0	139.2	121.8	104.3	86.9	
5625	72	182.7	12.2	130.4	111.4	92.4	73.4	-	-	169.5	13.5	124.3	105.6	86.9	68.2	-	-
	67	165.9	12.0	159.7	141.3	122.3	103.4	84.4	-	153.5	13.4	150.4	136.1	117.4	98.7	80.0	-
	62	150.2	11.9	150.2	150.2	147.9	128.9	109.9	90.9	140.7	13.2	140.7	140.7	139.8	121.1	102.4	83.7
	57	148.2	11.8	148.2	148.2	149.6	130.6	111.6	92.6	138.7	13.2	138.7	138.7	140.3	121.6	102.9	84.2
6250	72	186.6	12.2	138.8	118.5	98.3	78.0	-	-	172.8	13.5	132.3	112.4	92.4	72.5	-	-
	67	169.4	12.0	169.4	150.4	130.1	109.8	89.5	-	156.5	13.4	156.5	144.8	124.8	104.9	84.9	-
	62	153.4	11.9	153.4	153.4	153.4	133.1	112.8	92.5	143.4	13.2	143.4	143.4	143.4	123.5	103.5	83.6
	57	151.4	11.9	151.4	151.4	151.4	131.1	110.8	90.5	141.4	13.2	141.4	141.4	141.4	121.4	101.5	81.5

ZF150 (12.5 Ton) (Continued)

Air on Evaporator Coil		Temperature of Air on Condenser Coil																	
CFM	WB (°F)	Total Capacity ¹ (MBh)	Total Input (kW) ²	Sensible Capacity (MBh)								Total Capacity ¹ (MBh)	Total Input (kW) ²	Sensible Capacity (MBh)					
				Return Dry Bulb (°F)										Return Dry Bulb (°F)					
				90	85	80	75	70	65	90	85			80	75	70	65		
				115°F								125°F							
3125	77	152.8	14.9	60.7	48.8	36.4	-	-	-	140.3	16.2	52.4	44.0	31.5	-	-	-		
	72	139.4	14.8	83.7	71.3	58.8	46.3	-	-	127.6	16.2	79.0	66.6	54.2	41.7	-	-		
	67	125.9	14.7	106.7	93.7	81.2	68.8	56.3	-	114.9	16.1	102.4	89.2	76.8	64.4	51.9	-		
	62	117.0	14.5	117.0	117.0	100.3	87.8	75.4	62.9	108.6	15.9	108.6	108.6	94.4	82.0	69.6	57.2		
3750	77	158.0	14.9	68.1	54.0	40.0	-	-	-	145.1	16.3	62.7	48.8	34.9	-	-	-		
	72	144.1	14.8	92.7	78.7	64.6	50.6	-	-	132.0	16.2	87.7	73.8	59.8	45.9	-	-		
	67	130.1	14.7	117.4	103.3	89.3	75.2	-	-	118.9	16.1	112.6	98.7	84.8	70.8	56.9	-		
	62	121.0	14.5	121.0	121.0	110.2	96.2	82.1	68.1	112.4	15.9	112.4	112.4	104.3	90.3	76.4	62.5		
	57	119.1	14.6	119.1	119.1	110.7	96.6	82.6	68.5	110.5	16.0	110.5	110.5	102.6	88.6	74.7	60.8		
4375	77	163.2	14.9	75.4	59.2	43.6	-	-	-	150.0	16.3	73.0	53.7	38.2	-	-	-		
	72	148.8	14.8	101.7	86.1	70.5	54.8	-	-	136.4	16.2	96.4	80.9	65.5	50.0	-	-		
	67	134.4	14.7	128.0	113.0	97.3	81.7	-	-	122.9	16.1	122.8	108.2	92.8	77.3	61.9	-		
	62	125.0	14.6	125.0	125.0	120.1	104.5	88.9	73.3	116.1	15.9	116.1	116.1	114.1	98.7	83.2	67.8		
	57	123.0	14.6	123.0	123.0	120.6	105.0	89.4	73.8	114.2	16.0	114.2	114.2	112.3	96.8	81.4	66.0		
5000	77	168.3	15.0	82.8	64.4	47.2	-	-	-	154.8	16.3	83.3	58.5	41.5	-	-	-		
	72	153.5	14.9	110.7	93.5	76.3	59.1	-	-	140.8	16.3	105.1	88.1	71.2	54.2	-	-		
	67	138.7	14.8	138.7	122.6	105.4	88.2	71.0	-	126.8	16.2	126.8	117.7	100.8	83.8	66.8	-		
	62	128.9	14.6	128.9	128.9	130.1	112.9	95.7	78.4	119.9	16.0	119.9	119.9	119.9	107.0	90.0	73.1		
	57	126.9	14.6	126.9	126.9	130.6	113.4	96.2	79.0	117.9	16.0	117.9	117.9	117.9	105.0	88.1	71.1		
5625	72	156.2	14.9	118.3	99.9	81.4	63.0	-	-	143.0	16.2	112.2	94.1	75.9	57.8	-	-		
	67	141.1	14.8	141.1	130.9	112.5	94.1	75.6	-	128.7	16.2	128.7	125.7	107.6	89.4	71.3	-		
	62	131.2	14.6	131.2	131.2	131.8	113.3	94.9	76.5	121.7	16.0	121.7	121.7	121.7	105.6	87.5	69.3		
	57	129.2	14.6	129.2	129.2	131.0	112.6	94.2	75.7	119.6	16.0	119.6	119.6	119.6	103.6	85.4	67.3		
6250	72	158.9	14.9	125.8	106.2	86.6	66.9	-	-	145.1	16.2	119.4	100.0	80.7	61.4	-	-		
	67	143.6	14.8	143.6	139.2	119.6	99.9	80.3	-	130.6	16.2	130.6	130.6	114.3	95.0	75.7	-		
	62	133.5	14.6	133.5	133.5	133.5	113.8	94.2	74.6	123.5	16.0	123.5	123.5	123.5	104.2	84.9	65.6		
	57	131.4	14.6	131.4	131.4	131.4	111.8	92.1	72.5	121.4	16.0	121.4	121.4	121.4	102.1	82.8	63.5		

1. These capacities are gross ratings. For net capacity, deduct air blower motor, MBh = 3.415 x kW. Refer to the appropriate Blower Performance Table for the kW of the supply air blower motor.
2. These ratings include the condenser fan motors (total 1 kW) and the compressor motors but not the supply air blower motor.

Airflow Performance

ZF078-150 Side Duct Application

ZF078 (6.5 Ton) Side Duct

Air Flow (CFM)	Available External Static Pressure - IWG ¹																			
	0.2		0.4		0.6		0.8		1.0		1.2		1.4		1.6		1.8		2.0	
	RPM	BHP	RPM	BHP	RPM	BHP	RPM	BHP	RPM	BHP	RPM	BHP	RPM	BHP	RPM	BHP	RPM	BHP	RPM	BHP
	Field Supplied Drive						Standard 1.5 HP & Drive						Hi Static 2 HP & Drive							
1800	751	0.22	813	0.43	872	0.62	929	0.78	985	0.93	1040	1.07	1095	1.20	1150	1.33	1206	1.46	1265	1.59
2000	776	0.35	838	0.56	897	0.75	954	0.92	1010	1.07	1064	1.20	1119	1.33	1175	1.46	1231	1.59	1289	1.72
2200	804	0.50	866	0.71	925	0.90	982	1.06	1038	1.21	1092	1.35	1147	1.48	1203	1.61	1259	1.73	1317	1.87
2400	835	0.66	897	0.87	956	1.06	1013	1.22	1069	1.37	1124	1.51	1178	1.64	1234	1.77	1290	1.90	1348	2.03
2600	869	0.84	931	1.05	990	1.24	1047	1.40	1103	1.55	1158	1.69	1212	1.82	1268	1.95	1324	2.07	1382	2.21
2800	906	1.03	968	1.25	1027	1.43	1084	1.60	1139	1.75	1194	1.89	1249	2.02	1304	2.14	1361	2.27	-	-
3000	945	1.25	1007	1.46	1066	1.65	1123	1.81	1179	1.96	1234	2.10	1288	2.23	-	-	-	-	-	-
3200	987	1.48	1048	1.69	1107	1.88	1165	2.04	1220	2.19	-	-	-	-	-	-	-	-	-	-
3400	1030	1.73	1092	1.94	1151	2.12	1208	2.29	-	-	-	-	-	-	-	-	-	-	-	-
	2 HP & Field Supplied Drive																			

1. Blower performance includes gas heat exchangers and 2" filters. See STATIC RESISTANCE table for additional applications.
2. See RPM SELECTION table to determine desired motor sheave setting and to determine the maximum continuous BHP.
3. kW = BHP x 0.932.

ZF090 (7.5 Ton) Side Duct

Air Flow (CFM)	Available External Static Pressure - IWG ¹																			
	0.2		0.4		0.6		0.8		1.0		1.2		1.4		1.6		1.8		2.0	
	RPM	BHP	RPM	BHP	RPM	BHP	RPM	BHP	RPM	BHP	RPM	BHP	RPM	BHP	RPM	BHP	RPM	BHP	RPM	BHP
	Field Supplied Drive				Standard 1.5 HP & Drive				Hi Static 3 HP & Drive											
2000	776	0.35	838	0.56	897	0.75	954	0.92	1010	1.07	1064	1.20	1119	1.33	1175	1.46	1231	1.59	1289	1.72
2200	804	0.50	866	0.71	925	0.90	982	1.06	1038	1.21	1092	1.35	1147	1.48	1203	1.61	1259	1.73	1317	1.87
2400	835	0.66	897	0.87	956	1.06	1013	1.22	1069	1.37	1124	1.51	1178	1.64	1234	1.77	1290	1.90	1348	2.03
2600	869	0.84	931	1.05	990	1.24	1047	1.40	1103	1.55	1158	1.69	1212	1.82	1268	1.95	1324	2.07	1382	2.21
2800	906	1.03	968	1.25	1027	1.43	1084	1.60	1139	1.75	1194	1.89	1249	2.02	1304	2.14	1361	2.27	1419	2.40
3000	945	1.25	1007	1.46	1066	1.65	1123	1.81	1179	1.96	1234	2.10	1288	2.23	1344	2.36	1400	2.48	1458	2.62
3200	987	1.48	1048	1.69	1107	1.88	1165	2.04	1220	2.19	1275	2.33	1330	2.46	1385	2.59	1442	2.71	1500	2.85
3400	1030	1.73	1092	1.94	1151	2.12	1208	2.29	1264	2.44	1319	2.58	1374	2.71	1429	2.84	1485	2.96	1544	3.10
3600	1076	1.99	1138	2.20	1197	2.39	1254	2.56	1310	2.71	1364	2.84	1419	2.97	1475	3.10	1531	3.23	1589	3.36
3800	1124	2.27	1185	2.48	1245	2.67	1302	2.84	1357	2.99	1412	3.12	1467	3.25	1522	3.38	-	-	-	-
	3 HP & Field Supplied Drive																			

1. Blower performance includes gas heat exchangers and 2" filters. See STATIC RESISTANCE table for additional applications.
2. See RPM SELECTION table to determine desired motor sheave setting and to determine the maximum continuous BHP.
3. kW = BHP x 0.932.

ZF102 (8.5 Ton) Side Duct

Air Flow (CFM)	Available External Static Pressure - IWG ¹																			
	0.2		0.4		0.6		0.8		1.0		1.2		1.4		1.6		1.8		2.0	
	RPM	BHP	RPM	BHP	RPM	BHP	RPM	BHP	RPM	BHP	RPM	BHP	RPM	BHP	RPM	BHP	RPM	BHP	RPM	BHP
	Field Supplied Drive				Standard 2 HP & Drive				Hi Static 3 HP & Drive											
2600	628	0.56	678	0.76	730	0.93	781	1.09	833	1.25	883	1.41	933	1.59	980	1.80	1025	2.05	1068	2.35
2800	648	0.67	698	0.87	750	1.04	801	1.20	853	1.36	903	1.52	953	1.70	1000	1.91	1046	2.16	1088	2.46
3000	666	0.80	717	1.00	768	1.17	820	1.33	871	1.49	922	1.65	971	1.83	1019	2.04	1064	2.29	1106	2.59
3200	684	0.95	735	1.15	786	1.32	838	1.48	889	1.63	940	1.80	989	1.98	1037	2.19	1082	2.44	1124	2.74
3400	702	1.11	753	1.31	804	1.48	856	1.64	907	1.79	958	1.96	1007	2.14	1055	2.35	1100	2.60	1142	2.90
3600	721	1.28	772	1.48	824	1.65	875	1.81	927	1.97	977	2.13	1027	2.31	1074	2.52	1119	2.77	-	-
3800	742	1.47	793	1.67	844	1.84	896	2.00	947	2.15	998	2.32	1047	2.50	1095	2.71	1140	2.96	-	-
4000	765	1.67	815	1.86	867	2.04	918	2.19	970	2.35	1020	2.51	1070	2.70	1117	2.91	-	-	-	-
4200	789	1.87	840	2.07	891	2.24	943	2.40	995	2.56	1045	2.72	1094	2.90	-	-	-	-	-	-
	3 HP & Field Supplied Drive																			

1. Blower performance includes gas heat exchangers and 2" filters. See STATIC RESISTANCE table for additional applications.
2. See RPM SELECTION table to determine desired motor sheave setting and to determine the maximum continuous BHP.
3. kW = BHP x 0.932.

ZF120 (10 Ton) Side Duct

Air Flow (CFM)	Available External Static Pressure - IWG ¹																			
	0.2		0.4		0.6		0.8		1.0		1.2		1.4		1.6		1.8		2.0	
	RPM	BHP	RPM	BHP	RPM	BHP	RPM	BHP	RPM	BHP	RPM	BHP	RPM	BHP	RPM	BHP	RPM	BHP	RPM	BHP
	Field Supplied Drive						Standard 2 HP & Drive						Hi Static 3 HP & Drive							
2600	675	0.53	726	0.74	776	0.94	824	1.12	870	1.30	914	1.48	957	1.65	1000	1.82	1041	1.99	1082	2.17
2800	686	0.63	738	0.84	787	1.04	835	1.23	881	1.41	925	1.58	969	1.76	1011	1.93	1052	2.10	1093	2.27
3000	699	0.75	750	0.96	800	1.16	847	1.34	893	1.52	938	1.70	981	1.87	1024	2.04	1065	2.21	1106	2.39
3200	713	0.88	764	1.09	814	1.28	861	1.47	907	1.65	952	1.83	995	2.00	1037	2.17	1079	2.34	1119	2.52
3400	728	1.02	779	1.23	829	1.43	877	1.61	923	1.79	967	1.97	1010	2.14	1053	2.31	1094	2.48	1135	2.66
3600	745	1.18	796	1.39	846	1.59	893	1.77	939	1.95	984	2.13	1027	2.30	1069	2.47	1111	2.64	1152	2.82
3800	763	1.36	815	1.57	864	1.76	912	1.95	958	2.13	1002	2.31	1046	2.48	1088	2.65	1129	2.82	1170	3.00
4000	783	1.55	835	1.76	884	1.96	932	2.15	978	2.33	1022	2.50	1066	2.67	1108	2.84	1149	3.02	1190	3.19
4200	805	1.77	856	1.98	906	2.17	953	2.36	999	2.54	1044	2.72	1087	2.89	1129	3.06	1171	3.23	1211	3.41
4400	828	2.00	879	2.21	929	2.41	976	2.59	1022	2.77	1067	2.95	1110	3.12	1152	3.29	-	-	-	-
4600	852	2.25	904	2.46	953	2.66	1001	2.85	1047	3.03	1092	3.20	1135	3.37	-	-	-	-	-	-
4800	879	2.52	930	2.73	980	2.93	1027	3.12	1073	3.30	-	-	-	-	-	-	-	-	-	-
5000	906	2.81	958	3.02	1007	3.22	1055	3.41	-	-	-	-	-	-	-	-	-	-	-	-
	3 HP & Field Supplied Drive																			

1. Blower performance includes gas heat exchangers and 2" filters. See STATIC RESISTANCE table for additional applications.
2. See RPM SELECTION table to determine desired motor sheave setting and to determine the maximum continuous BHP.
3. kW = BHP x 0.932.

ZF150 (12.5 Ton) Side Duct

Air Flow (CFM)	Available External Static Pressure - IWG ¹																			
	0.2		0.4		0.6		0.8		1.0		1.2		1.4		1.6		1.8		2.0	
	RPM	BHP	RPM	BHP	RPM	BHP	RPM	BHP	RPM	BHP	RPM	BHP	RPM	BHP	RPM	BHP	RPM	BHP	RPM	BHP
	3 HP & Field Supplied Drive						Standard 3 HP & Drive						Hi Static 5 HP & Drive							
3200	684	1.00	741	1.16	794	1.32	844	1.48	892	1.65	940	1.81	988	1.97	1036	2.12	1087	2.27	1141	2.42
3400	709	1.15	765	1.30	818	1.46	868	1.62	916	1.79	964	1.95	1012	2.11	1061	2.26	1112	2.42	1166	2.56
3600	734	1.30	791	1.46	844	1.62	894	1.78	942	1.94	990	2.10	1038	2.26	1087	2.42	1137	2.57	1191	2.72
3800	761	1.48	818	1.63	871	1.79	921	1.95	969	2.12	1017	2.28	1065	2.44	1114	2.59	1164	2.75	1218	2.89
4000	789	1.66	846	1.82	899	1.98	949	2.14	997	2.31	1045	2.47	1093	2.63	1142	2.78	1192	2.93	1246	3.08
4200	818	1.87	875	2.03	928	2.19	978	2.35	1026	2.51	1074	2.67	1121	2.83	1170	2.99	1221	3.14	1275	3.29
4400	847	2.09	904	2.25	957	2.41	1007	2.57	1055	2.73	1103	2.90	1151	3.06	1199	3.21	1250	3.36	1304	3.51
4600	877	2.33	934	2.49	986	2.65	1036	2.81	1085	2.97	1132	3.14	1180	3.29	1229	3.45	1280	3.60	1334	3.75
4800	907	2.59	963	2.75	1016	2.91	1066	3.07	1115	3.23	1162	3.39	1210	3.55	1259	3.71	1310	3.86	1364	4.01
5000	937	2.86	993	3.02	1046	3.18	1096	3.34	1145	3.50	1192	3.66	1240	3.82	1289	3.98	1340	4.13	1394	4.28
5200	967	3.15	1023	3.31	1076	3.47	1126	3.63	1175	3.79	1222	3.95	1270	4.11	1319	4.27	1370	4.42	1424	4.57
5400	997	3.45	1053	3.61	1106	3.77	1156	3.93	1205	4.09	1252	4.26	1300	4.41	1349	4.57	1400	4.72	1454	4.87
5600	1027	3.77	1083	3.93	1136	4.09	1186	4.25	1235	4.41	1282	4.57	1330	4.73	1379	4.89	1430	5.04	1484	5.19
5800	1057	4.11	1113	4.26	1166	4.42	1216	4.59	1264	4.75	1312	4.91	1360	5.07	1409	5.22	-	-	-	-
6000	1086	4.46	1143	4.61	1196	4.77	1246	4.93	1294	5.10	1342	5.26	-	-	-	-	-	-	-	-
6200	1116	4.82	1172	4.98	1225	5.14	1275	5.30	-	-	-	-	-	-	-	-	-	-	-	-
	Hi Static 5 HP & Drive						5 HP & Field Supplied Drive													

1. Blower performance includes gas heat exchangers and 2" filters. See STATIC RESISTANCE table for additional applications.
2. See RPM SELECTION table to determine desired motor sheave setting and to determine the maximum continuous BHP.
3. kW = BHP x 0.932.

ZF078-150 Bottom Duct Application

ZF078 (6.5 Ton) Bottom Duct

Air Flow (CFM)	Available External Static Pressure - IWG ¹																			
	0.2		0.4		0.6		0.8		1.0		1.2		1.4		1.6		1.8		2.0	
	RPM	BHP	RPM	BHP	RPM	BHP	RPM	BHP	RPM	BHP	RPM	BHP	RPM	BHP	RPM	BHP	RPM	BHP	RPM	BHP
	Field Supplied Drive				Standard 1.5 HP & Drive				Hi Static 2 HP & Drive											
1800	775	0.31	850	0.53	924	0.72	998	0.89	1072	1.05	1147	1.20	1224	1.35	1303	1.51	1384	1.69	1469	1.89
2000	803	0.45	878	0.67	952	0.86	1026	1.03	1100	1.19	1175	1.34	1252	1.49	1331	1.65	1412	1.83	1497	2.03
2200	838	0.60	913	0.82	986	1.01	1060	1.19	1134	1.34	1210	1.49	1286	1.65	1365	1.81	1447	1.98	1532	2.18
2400	878	0.78	953	1.00	1027	1.19	1100	1.36	1174	1.52	1250	1.67	1327	1.82	1405	1.98	1487	2.16	-	-
2600	923	0.98	997	1.20	1071	1.39	1145	1.56	1219	1.72	1294	1.87	1371	2.02	1450	2.18	-	-	-	-
2800	971	1.20	1046	1.42	1119	1.61	1193	1.78	1267	1.94	1343	2.09	1419	2.24	-	-	-	-	-	-
3000	1023	1.44	1097	1.66	1171	1.85	1245	2.03	1319	2.18	-	-	-	-	-	-	-	-	-	-
3200	1077	1.71	1151	1.93	1225	2.12	1299	2.29	-	-	-	-	-	-	-	-	-	-	-	-
3400	1133	1.99	1208	2.21	-	-	-	-	-	-	-	-	-	-	-	-	-	-	-	-
	2 HP & Field Supplied Drive																			

1. Blower performance includes gas heat exchangers and 2" filters. See STATIC RESISTANCE table for additional applications.
2. See RPM SELECTION table to determine desired motor sheave setting and to determine the maximum continuous BHP.
3. kW = BHP x 0.932.

ZF090 (7.5 Ton) Bottom Duct

Air Flow (CFM)	Available External Static Pressure - IWG ¹																			
	0.2		0.4		0.6		0.8		1.0		1.2		1.4		1.6		1.8		2.0	
	RPM	BHP	RPM	BHP	RPM	BHP	RPM	BHP	RPM	BHP	RPM	BHP	RPM	BHP	RPM	BHP	RPM	BHP	RPM	BHP
	Field Supplied Drive				Standard 1.5 HP & Drive				Hi Static 3 HP & Drive											
2000	803	0.45	878	0.67	952	0.86	1026	1.03	1100	1.19	1175	1.34	1252	1.49	1331	1.65	1412	1.83	1497	2.03
2200	838	0.60	913	0.82	986	1.01	1060	1.19	1134	1.34	1210	1.49	1286	1.65	1365	1.81	1447	1.98	1532	2.18
2400	878	0.78	953	1.00	1027	1.19	1100	1.36	1174	1.52	1250	1.67	1327	1.82	1405	1.98	1487	2.16	1572	2.36
2600	923	0.98	997	1.20	1071	1.39	1145	1.56	1219	1.72	1294	1.87	1371	2.02	1450	2.18	1532	2.36	1617	2.56
2800	971	1.20	1046	1.42	1119	1.61	1193	1.78	1267	1.94	1343	2.09	1419	2.24	1498	2.40	1580	2.58	1665	2.78
3000	1023	1.44	1097	1.66	1171	1.85	1245	2.03	1319	2.18	1394	2.33	1471	2.49	1550	2.65	1632	2.82	1717	3.02
3200	1077	1.71	1151	1.93	1225	2.12	1299	2.29	1373	2.45	1448	2.60	1525	2.75	1604	2.91	1686	3.09	1771	3.29
3400	1133	1.99	1208	2.21	1282	2.41	1356	2.58	1430	2.73	1505	2.88	1582	3.04	1661	3.20	1742	3.37	-	-
3600	1192	2.30	1267	2.52	1341	2.71	1414	2.88	1489	3.04	1564	3.19	1641	3.34	-	-	-	-	-	-
3800	1253	2.63	1327	2.85	1401	3.04	1475	3.21	1549	3.37	-	-	-	-	-	-	-	-	-	-
	3 HP & Field Supplied Drive																			

1. Blower performance includes gas heat exchangers and 2" filters. See STATIC RESISTANCE table for additional applications.
2. See RPM SELECTION table to determine desired motor sheave setting and to determine the maximum continuous BHP.
3. kW = BHP x 0.932.

ZF102 (8.5 Ton) Bottom Duct

Air Flow (CFM)	Available External Static Pressure - IWG ¹																			
	0.2		0.4		0.6		0.8		1.0		1.2		1.4		1.6		1.8		2.0	
	RPM	BHP	RPM	BHP	RPM	BHP	RPM	BHP	RPM	BHP	RPM	BHP	RPM	BHP	RPM	BHP	RPM	BHP	RPM	BHP
	FS ⁴				Standard 2 HP & Drive				Hi Static 3 HP & Drive											
2600	674	0.71	731	0.88	786	1.05	838	1.24	887	1.42	933	1.59	974	1.74	1010	1.87	1040	1.97	1064	2.03
2800	689	0.86	746	1.02	801	1.20	854	1.38	903	1.56	948	1.73	989	1.88	1025	2.01	1056	2.11	1080	2.17
3000	707	1.01	764	1.17	819	1.35	872	1.53	921	1.71	966	1.88	1007	2.03	1043	2.16	1074	2.26	1098	2.32
3200	728	1.17	785	1.33	840	1.51	892	1.69	941	1.87	987	2.04	1028	2.20	1064	2.33	1094	2.42	1118	2.48
3400	751	1.34	808	1.51	863	1.68	915	1.87	964	2.05	1010	2.22	1051	2.37	1087	2.50	1117	2.60	1141	2.66
3600	776	1.53	833	1.70	888	1.87	941	2.06	990	2.24	1035	2.41	1076	2.56	1112	2.69	1142	2.79	1167	2.85
3800	804	1.74	861	1.90	916	2.08	969	2.26	1018	2.44	1063	2.61	1104	2.77	1140	2.90	1170	2.99	1194	-
4000	835	1.97	892	2.13	947	2.31	999	2.49	1048	2.67	1094	2.84	1135	2.99	-	-	-	-	-	-
4200	867	2.21	924	2.37	979	2.55	1032	2.73	1081	2.91	1127	3.08	-	-	-	-	-	-	-	-
	3 HP & Field Supplied Drive																			

1. Blower performance includes gas heat exchangers and 2" filters. See STATIC RESISTANCE table for additional applications.
2. See RPM SELECTION table to determine desired motor sheave setting and to determine the maximum continuous BHP.
3. kW = BHP x 0.932
4. Field Supplied Drive.

ZF120 (10 Ton) Bottom Duct

Air Flow (CFM)	Available External Static Pressure - IWG ¹																			
	0.2		0.4		0.6		0.8		1.0		1.2		1.4		1.6		1.8		2.0	
	RPM	BHP	RPM	BHP	RPM	BHP	RPM	BHP	RPM	BHP	RPM	BHP	RPM	BHP	RPM	BHP	RPM	BHP	RPM	BHP
	Field Supplied Drive				Standard 2 HP & Drive						Hi Static 3 HP & Drive									
2600	722	0.83	776	0.97	828	1.11	878	1.25	926	1.37	973	1.50	1018	1.62	1063	1.74	1106	1.86	1149	1.99
2800	744	0.97	798	1.12	850	1.26	900	1.39	949	1.52	995	1.64	1041	1.76	1085	1.88	1128	2.00	1171	2.13
3000	769	1.13	823	1.28	875	1.42	925	1.55	974	1.68	1020	1.80	1066	1.92	1110	2.05	1153	2.17	1196	2.29
3200	797	1.32	851	1.46	903	1.60	953	1.74	1001	1.86	1048	1.99	1093	2.11	1138	2.23	1181	2.35	1224	2.48
3400	828	1.52	882	1.67	934	1.81	983	1.94	1032	2.07	1078	2.19	1124	2.32	1168	2.44	1212	2.56	1254	2.68
3600	861	1.75	915	1.90	967	2.04	1017	2.17	1065	2.30	1112	2.42	1157	2.54	1201	2.67	1245	2.79	1287	2.91
3800	897	2.00	951	2.15	1002	2.29	1052	2.42	1101	2.55	1147	2.67	1193	2.80	1237	2.92	1280	3.04	1323	3.16
4000	935	2.27	989	2.42	1041	2.56	1091	2.69	1139	2.82	1186	2.95	1231	3.07	1275	3.19	1319	3.31	1362	3.43
4200	976	2.57	1030	2.72	1082	2.86	1132	2.99	1180	3.12	1227	3.24	1272	3.36	-	-	-	-	-	-
4400	1019	2.88	1073	3.03	1125	3.17	1175	3.30	1223	3.43	-	-	-	-	-	-	-	-	-	-
4600	1065	3.22	1119	3.36	-	-	-	-	-	-	-	-	-	-	-	-	-	-	-	-
	3 HP & Field Supplied Drive																			

1. Blower performance includes gas heat exchangers and 2" filters. See STATIC RESISTANCE table for additional applications.
2. See RPM SELECTION table to determine desired motor sheave setting and to determine the maximum continuous BHP.
3. kW = BHP x 0.932.

ZF150 (12.5 Ton) Bottom Duct

Air Flow (CFM)	Available External Static Pressure - IWG ¹																			
	0.2		0.4		0.6		0.8		1.0		1.2		1.4		1.6		1.8		2.0	
	RPM	BHP	RPM	BHP	RPM	BHP	RPM	BHP	RPM	BHP	RPM	BHP	RPM	BHP	RPM	BHP	RPM	BHP	RPM	BHP
	3 HP & Field Supplied Drive				Standard 3 HP & Drive						Hi Static 5 HP & Drive									
3200	823	1.28	861	1.47	906	1.64	955	1.80	1007	1.95	1059	2.12	1109	2.29	1155	2.50	1194	2.73	1225	3.01
3400	860	1.48	898	1.67	942	1.84	992	2.00	1044	2.16	1095	2.32	1145	2.50	1191	2.70	1231	2.94	1262	3.22
3600	898	1.71	935	1.90	980	2.07	1030	2.23	1081	2.39	1133	2.55	1183	2.73	1229	2.94	1269	3.17	1300	3.45
3800	936	1.97	974	2.16	1019	2.33	1068	2.49	1120	2.64	1172	2.81	1222	2.98	1267	3.19	1307	3.42	1338	3.70
4000	975	2.24	1013	2.43	1057	2.60	1107	2.76	1158	2.92	1210	3.08	1260	3.26	1306	3.46	1346	3.70	1377	3.97
4200	1014	2.54	1052	2.73	1096	2.90	1146	3.05	1197	3.21	1249	3.38	1299	3.55	1345	3.76	1385	3.99	1416	4.27
4400	1053	2.85	1091	3.04	1135	3.21	1185	3.37	1236	3.53	1288	3.69	1338	3.87	1384	4.07	1424	4.31	1455	4.58
4600	1091	3.19	1129	3.38	1174	3.55	1223	3.71	1275	3.86	1327	4.03	1377	4.20	1423	4.41	1462	4.64	1494	4.92
4800	1130	3.54	1168	3.73	1213	3.90	1262	4.06	1314	4.22	1365	4.38	1415	4.56	1461	4.76	1501	5.00	1532	5.27
5000	1168	3.92	1206	4.11	1251	4.28	1300	4.44	1352	4.59	1404	4.76	1454	4.94	1500	5.14	1539	5.37	-	-
5200	1206	4.31	1244	4.50	1288	4.67	1338	4.83	1389	4.99	1441	5.15	1491	5.33	1537	5.53	-	-	-	-
5400	1243	4.72	1281	4.91	1326	5.08	1375	5.24	1427	5.40	1479	5.56	-	-	-	-	-	-	-	-
5600	1280	5.15	1318	5.34	1362	5.51	-	-	-	-	-	-	-	-	-	-	-	-	-	-
5800	1316	5.60	-	-	-	-	-	-	-	-	-	-	-	-	-	-	-	-	-	-
	5 HP & Field Supplied Drive																			

1. Blower performance includes gas heat exchangers and 2" filters. See STATIC RESISTANCE table for additional applications.
2. See RPM SELECTION table to determine desired motor sheave setting and to determine the maximum continuous BHP.
3. kW = BHP x 0.932.

RPM Selection

Size (Tons)	Model	HP	Max BHP	Motor Sheave	Blower Sheave	6 Turns Open	5 Turns Open	4 Turns Open	3 Turns Open	2 Turns Open	1 Turn Open	Fully Closed
078 (6.5)	ZF	1.5	1.73	1VM50	AK74	N/A	887	936	986	1035	1084	1134
		2	2.30	1VM50	AK64	N/A	1039	1094	1150	1207	1256	1308
090 (7.5)	ZF	1.5	1.73	1VM50	AK74	N/A	887	936	986	1035	1084	1134
		3	3.45	1VM50	AK61	N/A	1088	1147	1205	1265	1312	1365
102 (8.5)	ZF	2	2.30	1VM50	AK94	N/A	690	728	767	805	843	882
		3	3.45	1VM50	AK74	N/A	887	936	986	1035	1084	1134
120 (10)	ZF	2	2.30	1VM50	AK84	N/A	776	819	863	906	949	992
		3	3.45	1VM50	AK74	N/A	887	936	986	1035	1084	1134
150 (12.5)	ZF	3	3.45	1VM50	AK74	N/A	887	936	986	1035	1084	1134
		5	5.75	1VP56	BK77	1052	1095	1136	1175	1216	1272	N/A

Additional Static Resistance

Size (Tons)	Model	CFM	Cooling Only ¹	Economizer ^{2,3}	4" Filter ²	Electric Heat kW ²				
						9	18	24	36	54
078 (6.5) 090 (7.5)	ZF	1900	0.00	0.07	0.10	0.05	0.06	0.07	0.08	0.10
		2100	-0.01	0.09	0.11	0.06	0.07	0.08	0.09	0.11
		2300	-0.01	0.11	0.12	0.07	0.08	0.09	0.10	0.13
		2500	-0.02	0.13	0.14	0.08	0.09	0.10	0.11	0.14
		2700	-0.03	0.16	0.15	0.09	0.10	0.12	0.13	0.16
		2900	-0.04	0.18	0.16	0.10	0.11	0.13	0.14	0.18
		3100	-0.05	0.20	0.18	0.12	0.13	0.15	0.16	0.20
		3300	-0.06	0.22	0.19	0.13	0.14	0.17	0.18	0.22
		3500	-0.07	0.24	0.20	0.15	0.16	0.19	0.20	0.24
		3700	-0.08	0.27	0.21	0.17	0.18	0.21	0.22	0.26
		3900	-0.09	0.29	0.23	0.19	0.20	0.23	0.24	0.28
		4100	-0.09	0.31	0.24	0.21	0.22	0.25	0.26	0.31
		4300	-0.10	0.30	0.25	0.23	0.24	0.28	0.29	0.34
		4500	-0.11	0.35	0.26	0.25	0.26	0.30	0.31	0.37
102 (8.5) 120 (10) 150 (12.5)	ZF	1900	0.06	0.02	0.12	0.05	0.06	0.07	0.08	0.10
		2100	0.07	0.02	0.13	0.06	0.07	0.08	0.09	0.11
		2300	0.08	0.02	0.14	0.07	0.08	0.09	0.10	0.13
		2500	0.09	0.02	0.16	0.08	0.09	0.10	0.11	0.14
		2700	0.11	0.03	0.17	0.09	0.10	0.12	0.13	0.16
		2900	0.12	0.03	0.19	0.10	0.11	0.13	0.14	0.18
		3100	0.14	0.03	0.20	0.12	0.13	0.15	0.16	0.20
		3300	0.16	0.03	0.22	0.13	0.14	0.17	0.18	0.22
		3500	0.18	0.04	0.26	0.15	0.16	0.19	0.20	0.24
		3700	0.20	0.04	0.27	0.17	0.18	0.21	0.22	0.26
		3900	0.23	0.04	0.29	0.19	0.20	0.23	0.24	0.28
		4100	0.25	0.04	0.32	0.21	0.22	0.25	0.26	0.31
		4300	0.28	0.05	0.35	0.23	0.24	0.28	0.29	0.34
		4500	0.30	0.05	0.38	0.25	0.26	0.30	0.31	0.37
		4700	0.33	0.05	0.41	0.28	0.29	0.33	0.34	0.40
		4900	0.36	0.05	0.44	0.30	0.31	0.35	0.37	0.43
		5100	0.39	0.06	0.47	0.33	0.34	0.38	0.40	0.46
		5300	0.42	0.06	0.51	0.35	0.37	0.41	0.43	0.49
		5500	0.45	0.06	0.55	0.38	0.40	0.44	0.46	0.53
5700	0.48	0.06	0.58	0.41	0.43	0.47	0.49	0.56		
5900	0.52	0.07	0.62	0.44	0.46	0.50	0.53	0.59		
6100	0.56	0.07	0.67	0.47	0.49	0.53	0.56	0.62		
6300	0.60	0.07	0.71	0.50	0.53	0.56	0.59	0.65		

1. Add these values to the available static resistance in the respective Blower Performance Tables.
2. Deduct these values from the available external static pressure shown in the respective Blower Performance Tables.
3. The pressure drop through the economizer is greater for 100% outdoor air than for 100% return air. If the resistance of the return air duct is less than 0.25 IWG, the unit will deliver less CFM during full economizer operation.

Drive Selection

1. Determine side or bottom supply duct Application.
2. Determine desired airflow.
3. Calculate or measure the amount of external static pressure.
4. Using the operating point determined from steps 1, 2 & 3, locate this point on the appropriate supply air blower performance table. (Linear interpolation may be necessary.)
5. Noting the RPM and BHP from step 4, locate the appropriate motor and, or drive on the RPM selection table.
6. Review the BHP compared to the motor options available. Select the appropriate motor and, or drive.
7. Review the RPM range for the motor options available. Select the appropriate drive if multiple drives are available for the chosen motor.
8. Determine turns open to obtain the desired operation point.

Example

1. 2600 CFM
2. 1.6 iwg
3. Using the supply air blower performance table below, the following data point was located: 1268 RPM & 1.95 BHP.
4. Using the RPM selection table below, Size X and Model Y is found.
5. 1.95 BHP exceeds the maximum continuous BHP rating of the 1.5 HP motor. The 2 HP motor is required.
6. 1268 RPM is within the range of the 2 HP drives.
7. Using the 2 HP motor and drive, .5 turns open will achieve 1268 RPM.

Airflow Performance**Example Supply Air Blower Performance**

Air Flow (CFM)	Available External Static Pressure - IWG																			
	0.2		0.4		0.6		0.8		1.0		1.2		1.4		1.6		1.8		2.0	
	RPM	BHP	RPM	BHP	RPM	BHP	RPM	BHP	RPM	BHP	RPM	BHP	RPM	BHP	RPM	BHP	RPM	BHP	RPM	BHP
	1.5 HP & Field Supplied Drive						Standard 1.5 HP & Drive						Alternate 2 HP & Drive							
2200	804	0.50	866	0.71	925	0.90	982	1.06	1038	1.21	1092	1.35	1147	1.48	1203	1.61	1259	1.73	1317	1.87
2400	835	0.66	897	0.87	956	1.06	1013	1.22	1069	1.37	1124	1.51	1178	1.64	1234	1.77	1290	1.90	1348	2.03
2600	869	0.84	931	1.05	990	1.24	1047	1.40	1103	1.55	1158	1.69	1212	1.82	1268	1.95	1324	2.07	1382	2.21
2800	906	1.03	968	1.25	1027	1.43	1084	1.60	1139	1.75	1194	1.89	1249	2.02	1304	2.14	1361	2.27	-	-

Table X: RPM Selection

Size (Tons)	Model	HP	Max BHP	Motor Sheave	Blower Sheave	6 Turns Open	5 Turns Open	4 Turns Open	3 Turns Open	2 Turns Open	1 Turn Open	Fully Closed
X	Y	1.5	1.73	1VM50	AK74	N/A	897	945	991	1035	1079	1126
		2	2.30	1VM50	AK64	N/A	1039	1094	1150	1207	1256	1308

Altitude/Temperature Correction Factors

Air Temp.	Altitude (Ft.)										
	0	1000	2000	3000	4000	5000	6000	7000	8000	9000	10000
40	1.060	1.022	0.986	0.950	0.916	0.882	0.849	0.818	0.788	0.758	0.729
50	1.039	1.002	0.966	0.931	0.898	0.864	0.832	0.802	0.772	0.743	0.715
60	1.019	0.982	0.948	0.913	0.880	0.848	0.816	0.787	0.757	0.729	0.701
70	1.000	0.964	0.930	0.896	0.864	0.832	0.801	0.772	0.743	0.715	0.688
80	0.982	0.947	0.913	0.880	0.848	0.817	0.787	0.758	0.730	0.702	0.676
90	0.964	0.929	0.897	0.864	0.833	0.802	0.772	0.744	0.716	0.689	0.663
100	0.946	0.912	0.880	0.848	0.817	0.787	0.758	0.730	0.703	0.676	0.651

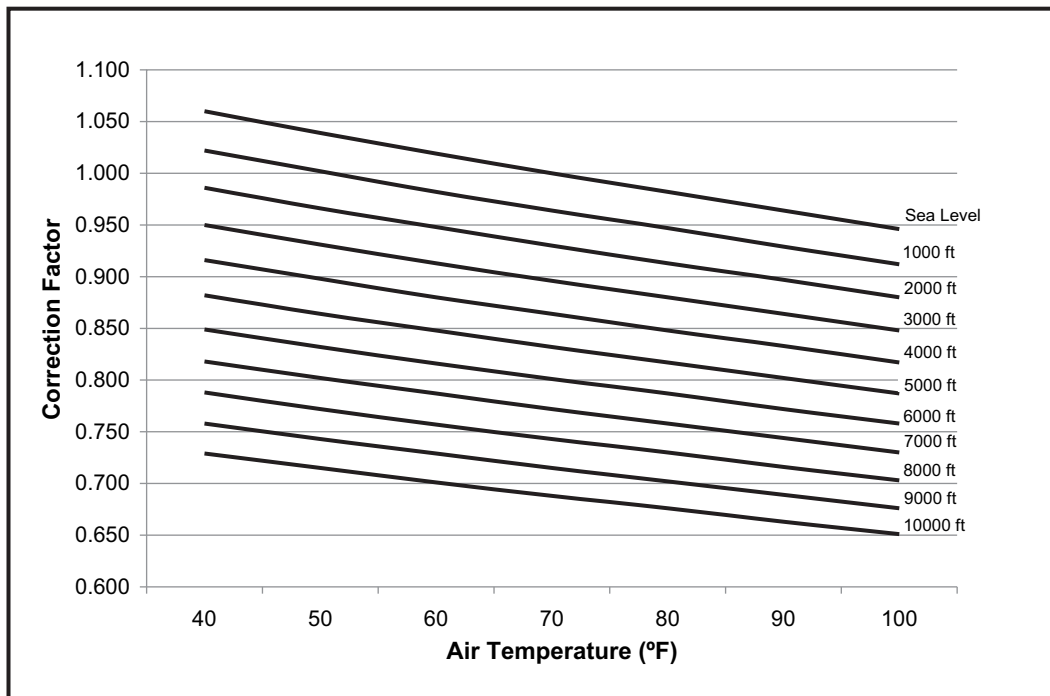

Gas Heat Minimum Supply Air

Size (Tons)	Model	Heat Size	Supply Air (CFM)			
			Cooling		Heating	
			Min	Max	Min	Max
078 (6.5)	ZF	10	1950	3250	1950	3250
		15	1950	3250	1950	3250
090 (7.5)	ZF	10	2250	3750	2250	3750
		15	2250	3750	2250	3750
102 (8.5)	ZF	10	2550	4250	2550	4250
		15	2550	4250	2550	4250
120 (10)	ZF	15	3000	5000	3000	5000
		20	3000	5000	3000	5000
150 (12.5)	ZF	15	3750	6250	3750	6250
		20	3750	6250	3750	6250

Electric Heat Minimum Supply Air

Size (Tons)	Model	Voltage	Minimum Supply Air (CFM)				
			Heater kW				
			9	18	24	36	54
078 (6.5)	ZF	208/230-3-60	1950	1950	1950	1950	-
		460-3-60	1950	1950	1950	1950	-
		600-3-60	1950	1950	1950	1950	-
090 (7.5)	ZF	208/230-3-60	2250	2250	2250	2250	-
		460-3-60	2250	2250	2250	2250	-
		600-3-60	2250	2250	2250	2250	-
102 (8.5)	ZF	208/230-3-60	2550	2550	2550	2550	-
		460-3-60	2550	2550	2550	2550	-
		600-3-60	2550	2550	2550	2550	-
120 (10)	ZF	208/230-3-60	-	3000	3000	3000	3500
		460-3-60	-	3000	3000	3000	3000
		600-3-60	-	3000	3000	3000	3500
150 (12.5)	ZF	208/230-3-60	-	3750	3750	3750	4000
		460-3-60	-	3750	3750	3750	3750
		600-3-60	-	3750	3750	3750	3750

Indoor Blower Specifications

Size (Tons)	Model	Motor					Motor Sheave			Blower Sheave			Belt
		HP	RPM	Eff.	SF	Frame	Datum Dia. (in.)	Bore (in.)	Model	Datum Dia. (in.)	Bore (in.)	Model	
078 (6.5)	ZF	1-1/2	1725	0.8	1.15	56	3.4 - 4.4	7/8	1VM50	7.0	1	AK74	A49
		2	1725	0.8	1.15	56	3.4 - 4.4	7/8	1VM50	6.0	1	AK64	A49
090 (7.5)	ZF	1-1/2	1725	0.8	1.15	56	3.4 - 4.4	7/8	1VM50	7.0	1	AK74	A49
		3	1725	0.8	1.15	56	3.4 - 4.4	7/8	1VM50	5.7	1	AK61	A49
102 (8.5)	ZF	2	1725	0.8	1.15	56	3.4 - 4.4	7/8	1VM50	9.0	1	AK94	A56
		3	1725	0.8	1.15	56	3.4 - 4.4	7/8	1VM50	7.0	1	AK74	A54
120 (10)	ZF	2	1725	0.8	1.15	56	3.4 - 4.4	7/8	1VM50	8.0	1	AK84	A56
		3	1725	0.8	1.15	56	3.4 - 4.4	7/8	1VM50	7.0	1	AK74	A54
150 (12.5)	ZF	3	1725	0.8	1.15	56	3.4 - 4.4	7/8	1VM50	7.0	1	AK74	A54
		5	1725	0.87	1.15	184T	4.3 - 5.3	1-1/8	1VP56	6.7	1	BK77	BX55

Power Exhaust Specifications

Model	Voltage	Motor			Motor			Fuse Size	CFM @ 0.1 ESP
		HP	RPM ¹	QTY	LRA	FLA	MCA		
2PE04703225	208/230-1-60	3/4	1075	1	7.8	5	6.3	10	3800
2PE04703246	460-1-60	3/4	1075	1	3.4	2.2	2.8	5	3800
2PE04703258	575-1-60	3/4	1050	1	2.9	1.5	1.9	4	3800

1. Motors are multi-tapped and factory wired for high speed.

Electric Heat Multipliers

Voltage		kW Capacity Multipliers ¹
Nominal	Applied	
240	208	0.75
	230	0.92
480	460	0.92
600	575	0.92

1. Electric heaters are rated at nominal voltage. Use this table to determine the electric heat capacity for heaters applied at lower voltages.

Sound Performance

Indoor Sound Power Levels

Size (Tons)	Model	CFM	ESP (IWG)	Blower		Sound Power, dB (10 ⁻¹²) Watts								
						RPM	BHP	Sound Rating ¹ dB (A)	Octave Band Centerline Frequency (Hz)					
				63	125				250	500	1000	2000	4000	8000
078 (6.5)	ZF	2600	0.6	812	1.14	74	71	73	73	71	69	65	65	60
090 (7.5)	ZF	3000	0.6	854	1.47	77	74	76	76	74	72	68	68	63
102 (8.5)	ZF	3400	0.6	872	1.65	80	77	79	79	77	75	71	71	66
120 (10)	ZF	4000	0.6	959	2.29	83	80	82	82	80	78	74	74	69
150 (12.5)	ZF	5000	0.6	1132	3.74	87	84	86	86	84	82	78	78	73

1. These values have been accessed using a model of sound propagation from a point source into the hemispheric/free field. The dBA values provided are to be used for reference only. Calculation of dBA values cover matters of system design and the fan manufacture has no way of knowing the details of each system. This constitutes an exception to any specification or guarantee requiring a dBA value of sound data in any other form than sound power level ratings.

Outdoor Sound Power Levels

ZF078-150

Size (Tons)	Model	Sound Rating ¹ dB (A)	Octave Band Centerline Frequency (Hz)							
			63	125	250	500	1000	2000	4000	8000
078 (6.5)	ZF	84	86.0	87.5	86.0	82.5	79.0	73.5	68.5	62.0
090 (7.5)	ZF	89	89.5	92.0	89.0	87.5	84.0	78.5	73.5	66.5
102 (8.5)	ZF	91	91.5	93.5	92.5	89.0	85.5	80.5	76.0	71.0
120 (10)	ZF	92	99.5	94.5	92.0	90.0	87.0	81.0	76.0	70.0
150 (12.5)	ZF	88	91.0	92.5	90.0	85.0	81.5	77.0	73.0	66.5

1. Rated in accordance with ARI 270 standard.

Electrical Data

ZF078-150 Standard Motor - Without Powered Convenience Outlet

Size (Tons)	Volt	Compressors (each)			OD Fan Motors (each)	Supply Blower Motor	Pwr Exh Motor	Pwr Conv Outlet	Electric Heat Option				MCA ¹ (Amps)	MCA ¹ w/Pwr Exh (Amps)	Max Fuse ² / Breaker ³ Size (Amps)	Max Fuse ² / Breaker ³ Size w/ Pwr Exh (Amps)
		RLA	LRA	MCC	FLA	FLA	FLA	FLA	Model	kW	Stages	Amps				
078 (6.5)	208	9.3	68	14.5	1.5	6.0	5.5	0	None	-	-	-	29.9	35.4	35	40
									E09	6.8	1	18.9	31.1	38	35	40
									E18	13.5	2	37.5	54.3	61.2	60	70
									E24	18	2	50.0	70	76.8	70	80
									E36	25.5	2	70.8	96	102.9	100	110
	230	9.3	68	14.5	1.5	6.0	5.5	0	None	-	-	-	29.9	35.4	35	40
									E09	9	1	21.7	34.6	41.4	35	45
									E18	18	2	43.3	61.6	68.5	70	70
									E24	24	2	57.7	79.7	86.5	80	90
									E36	34	2	81.8	109.7	116.6	110	125
	460	4.9	34	7.7	0.8	3.0	2.2	0	None	-	-	-	15.6	17.8	20	20
									E09	9	1	10.8	17.3	20	20	20
									E18	18	2	21.7	30.8	33.6	35	35
									E24	24	2	28.9	39.8	42.6	40	45
									E36	34	2	40.9	54.9	57.6	60	60
	575	3.8	28	6	0.6	2.4	1.8	0	None	-	-	-	12.2	14	15	15
									E09	9	1	8.7	13.8	16.1	15	20
									E18	18	2	17.3	24.7	26.9	25	30
									E24	24	2	23.1	31.9	34.1	35	35
									E36	34	2	32.7	43.9	46.1	45	50
090 (7.5)	208	11.9	88	18.5	3.5	6.0	5.5	0	None	-	-	-	39.8	45.3	50	50
									E09	6.8	1	18.9	39.8	45.3	50	50
									E18	13.5	2	37.5	54.3	61.2	60	70
									E24	18	2	50.0	70	76.8	70	80
									E36	25.5	2	70.8	96	102.9	100	110
	230	11.9	88	18.5	3.5	6.0	5.5	0	None	-	-	-	39.8	45.3	50	50
									E09	9	1	21.7	39.8	45.3	50	50
									E18	18	2	43.3	61.6	68.5	70	70
									E24	24	2	57.7	79.7	86.5	80	90
									E36	34	2	81.8	109.7	116.6	110	125
	460	5.2	44	8.1	1.6	3.0	2.2	0	None	-	-	-	17.9	20.1	20	25
									E09	9	1	10.8	17.9	20.1	20	25
									E18	18	2	21.7	30.8	33.6	35	35
									E24	24	2	28.9	39.8	42.6	40	45
									E36	34	2	40.9	54.9	57.6	60	60
	575	4.8	36	7.5	1.3	2.4	1.8	0	None	-	-	-	15.8	17.6	20	20
									E09	9	1	8.7	15.8	17.6	20	20
									E18	18	2	17.3	24.7	26.9	25	30
									E24	24	2	23.1	31.9	34.1	35	35
									E36	34	2	32.7	43.9	46.1	45	50
102 (8.5)	208	12.2	88	19	3.5	6.8	5.5	0	None	-	-	-	41.3	46.8	50	50
									E09	6.8	1	18.9	41.3	46.8	50	50
									E18	13.5	2	37.5	55.3	62.2	60	70
									E24	18	2	50.0	71	77.8	80	80
									E36	25.5	2	70.8	97	103.9	100	110
	230	12.2	88	19	3.5	6.8	5.5	0	None	-	-	-	41.3	46.8	50	50
									E09	9	1	21.7	41.3	46.8	50	50
									E18	18	2	43.3	62.6	69.5	70	70
									E24	24	2	57.7	80.7	87.5	90	90
									E36	34	2	81.8	110.7	117.6	125	125
	460	5.8	44	9	1.6	3.4	2.2	0	None	-	-	-	19.7	21.9	25	25
									E09	9	1	10.8	19.7	21.9	25	25
									E18	18	2	21.7	31.3	34.1	35	35
									E24	24	2	28.9	40.3	43.1	45	45
									E36	34	2	40.9	55.4	58.1	60	60
	575	4.4	36	5.5	1.3	2.7	1.8	0	None	-	-	-	15.2	17	20	20
									E09	9	1	8.7	15.2	17	20	20
									E18	18	2	17.3	25	27.3	25	30
									E24	24	2	23.1	32.2	34.5	35	35
									E36	34	2	32.7	44.3	46.5	45	50

ZF078-150 Standard Motor - Without Powered Convenience Outlet (Continued)

Size (Tons)	Volt	Compressors (each)			OD Fan Motors (each)	Supply Blower Motor	Pwr Exh Motor	Pwr Conv Outlet	Electric Heat Option				MCA ¹ (Amps)	MCA ¹ w/Pwr Exh (Amps)	Max Fuse ² / Breaker ³ Size (Amps)	Max Fuse ² / Breaker ³ Size w/ Pwr Exh (Amps)
		RLA	LRA	MCC	FLA	FLA	FLA	FLA	Model	kW	Stages	Amps				
120 (10)	208	13.9	110	21.7	3.5	6.8	5.5	0	None	-	-	-	45.1	50.6	50	60
									E18	13.5	2	37.5	55.3	62.2	60	70
									E24	18	2	50.0	71	77.8	80	80
									E36	25.5	2	70.8	97	103.9	100	110
									E54	40.6	2	112.7	149.4	156.2	150	175
	230	13.9	110	21.7	3.5	6.8	5.5	0	None	-	-	-	45.1	50.6	50	60
									E18	18	2	43.3	62.6	69.5	70	70
									E24	24	2	57.7	80.7	87.5	90	90
									E36	34	2	81.8	110.7	117.6	125	125
									E54	54	2	129.9	138.4	145.3	150	175
	460	7.4	55	11.5	1.6	3.4	2.2	0	None	-	-	-	23.3	25.5	30	30
									E18	18	2	21.7	31.3	34.1	35	35
									E24	24	2	28.9	40.3	43.1	45	45
									E36	34	2	40.9	55.4	58.1	60	60
									E54	54	2	65.0	69.2	72	80	80
	575	5.6	43	8.7	1.3	2.7	1.8	0	None	-	-	-	17.9	19.7	20	25
									E18	18	2	17.3	25	27.3	25	30
									E24	24	2	23.1	32.2	34.5	35	35
									E36	34	2	32.7	44.3	46.5	45	50
									E54	54	2	52.0	55.3	57.6	60	60
150 (12.5)	208	23.1	160	36	3.5	9.6	5.5	0	None	-	-	-	75.6	81.1	90	100
									E18	13.5	2	37.5	75.6	81.1	90	100
									E24	18	2	50.0	75.6	81.3	90	100
									E36	25.5	2	70.8	100.5	107.4	110	110
									E54	40.6	2	112.7	152.9	159.7	175	175
	230	23.1	160	36	3.5	9.6	5.5	0	None	-	-	-	75.6	81.1	90	100
									E18	18	2	43.3	75.6	81.1	90	100
									E24	24	2	57.7	84.2	91.0	90	100
									E36	34	2	81.8	114.2	121.1	125	125
									E54	54	2	129.9	141.9	148.8	175	175
	460	12.2	87	19	1.6	4.8	2.2	0	None	-	-	-	38.7	40.9	50	50
									E18	18	2	21.7	38.7	40.9	50	50
									E24	24	2	28.9	42.1	44.8	50	50
									E36	34	2	40.9	57.1	59.9	60	60
									E54	54	2	65.0	71.0	73.7	80	80
	575	8.7	62	13.5	1.3	3.9	1.8	0	None	-	-	-	28.7	30.5	35	35
									E18	18	2	17.3	28.7	30.5	35	35
									E24	24	2	23.1	33.7	36.0	35	40
									E36	34	2	32.7	45.8	48.0	50	50
									E54	54	2	52.0	56.8	59.1	70	70

1. Minimum Circuit Ampacity.
2. Dual Element, Time Delay Type.
3. HACR type per NEC.

ZF078-150 Hi Static Motor - Without Powered Convenience Outlet

Size (Tons)	Volt	Compressors (each)			OD Fan Motors (each)	Supply Blower Motor	Pwr Exh Motor	Pwr Conv Outlet	Electric Heat Option				MCA ¹ (Amps)	MCA ¹ w/Pwr Exh (Amps)	Max Fuse ^{2/} Breaker ³ Size (Amps)	Max Fuse ^{2/} Breaker ³ Size w/ Pwr Exh (Amps)
		RLA	LRA	MCC	FLA	FLA	FLA	FLA	Model	kW	Stages	Amps				
078 (6.5)	208	9.3	68	14.5	1.5	6.8	5.5	0	None	-	-	-	30.7	36.2	40	45
									E09	6.8	1	18.9	32.1	39	40	45
									E18	13.5	2	37.5	55.3	62.2	60	70
									E24	18	2	50.0	71	77.8	80	80
									E36	25.5	2	70.8	97	103.9	100	110
	230	9.3	68	14.5	1.5	6.8	5.5	0	None	-	-	-	30.7	36.2	40	45
									E09	9	1	21.7	35.6	42.4	40	45
									E18	18	2	43.3	62.6	69.5	70	70
									E24	24	2	57.7	80.7	87.5	90	90
									E36	34	2	81.8	110.7	117.6	125	125
	460	4.9	34	7.7	0.8	3.4	2.2	0	None	-	-	-	16	18.2	20	20
									E09	9	1	10.8	17.8	20.5	20	25
									E18	18	2	21.7	31.3	34.1	35	35
									E24	24	2	28.9	40.3	43.1	45	45
									E36	34	2	40.9	55.4	58.1	60	60
	575	3.8	28	6	0.6	2.7	1.8	0	None	-	-	-	12.5	14.3	15	15
									E09	9	1	8.7	14.2	16.5	15	20
									E18	18	2	17.3	25	27.3	25	30
									E24	24	2	23.1	32.2	34.5	35	35
									E36	34	2	32.7	44.3	46.5	45	50
090 (7.5)	208	11.9	88	18.5	3.5	9.6	5.5	0	None	-	-	-	43.4	48.9	50	60
									E09	6.8	1	18.9	43.4	48.9	50	60
									E18	13.5	2	37.5	58.8	65.7	60	70
									E24	18	2	50.0	74.5	81.3	80	90
									E36	25.5	2	70.8	100.5	107.4	110	110
	230	11.9	88	18.5	3.5	9.6	5.5	0	None	-	-	-	43.4	48.9	50	60
									E09	9	1	21.7	43.4	48.9	50	60
									E18	18	2	43.3	66.1	73	70	80
									E24	24	2	57.7	84.2	91	90	100
									E36	34	2	81.8	114.2	121.1	125	125
	460	5.2	44	8.1	1.6	4.8	2.2	0	None	-	-	-	19.7	21.9	20	25
									E09	9	1	10.8	19.7	22.3	20	25
									E18	18	2	21.7	33.1	35.8	35	40
									E24	24	2	28.9	42.1	44.8	45	45
									E36	34	2	40.9	57.1	59.9	60	60
	575	4.8	36	7.5	1.3	3.9	1.8	0	None	-	-	-	17.3	19.1	20	20
									E09	9	1	8.7	17.3	19.1	20	20
									E18	18	2	17.3	26.5	28.8	30	30
									E24	24	2	23.1	33.7	36	35	40
									E36	34	2	32.7	45.8	48	50	50
102 (8.5)	208	12.2	88	19	3.5	9.6	5.5	0	None	-	-	-	44.1	49.6	50	60
									E09	6.8	1	18.9	44.1	49.6	50	60
									E18	13.5	2	37.5	58.8	65.7	60	70
									E24	18	2	50.0	74.5	81.3	80	90
									E36	25.5	2	70.8	100.5	107.4	110	110
	230	12.2	88	19	3.5	9.6	5.5	0	None	-	-	-	44.1	49.6	50	60
									E09	9	1	21.7	44.1	49.6	50	60
									E18	18	2	43.3	66.1	73	70	80
									E24	24	2	57.7	84.2	91	90	100
									E36	34	2	81.8	114.2	121.1	125	125
	460	5.8	44	9	1.6	4.8	2.2	0	None	-	-	-	21.1	23.3	25	25
									E09	9	1	10.8	21.1	23.3	25	25
									E18	18	2	21.7	33.1	35.8	35	40
									E24	24	2	28.9	42.1	44.8	45	45
									E36	34	2	40.9	57.1	59.9	60	60
	575	4.4	36	5.5	1.3	3.9	1.8	0	None	-	-	-	16.4	18.2	20	20
									E09	9	1	8.7	16.4	18.2	20	20
									E18	18	2	17.3	26.5	28.8	30	30
									E24	24	2	23.1	33.7	36	35	40
									E36	34	2	32.7	45.8	48	50	50

ZF078-150 Hi Static Motor - Without Powered Convenience Outlet (Continued)

Size (Tons)	Volt	Compressors (each)			OD Fan Motors (each)	Supply Blower Motor	Pwr Exh Motor	Pwr Conv Outlet	Electric Heat Option				MCA ¹ (Amps)	MCA ¹ w/Pwr Exh (Amps)	Max Fuse ² / Breaker ³ Size (Amps)	Max Fuse ² / Breaker ³ Size w/ Pwr Exh (Amps)
		RLA	LRA	MCC	FLA	FLA	FLA	FLA	Model	kW	Stages	Amps				
120 (10)	208	13.9	110	21.7	3.5	9.6	5.5	0	None	-	-	-	47.9	53.4	60	60
									E18	13.5	2	37.5	58.8	65.7	60	70
									E24	18	2	50.0	74.5	81.3	80	90
									E36	25.5	2	70.8	100.5	107.4	110	110
									E54	40.6	2	112.7	152.9	159.7	175	175
	230	13.9	110	21.7	3.5	9.6	5.5	0	None	-	-	-	47.9	53.4	60	60
									E18	18	2	43.3	66.1	73	70	80
									E24	24	2	57.7	84.2	91	90	100
									E36	34	2	81.8	114.2	121.1	125	125
									E54	54	2	129.9	141.9	148.8	175	175
	460	7.4	55	11.5	1.6	4.8	2.2	0	None	-	-	-	24.7	26.9	30	30
									E18	18	2	21.7	33.1	35.8	35	40
									E24	24	2	28.9	42.1	44.8	45	45
									E36	34	2	40.9	57.1	59.9	60	60
									E54	54	2	65.0	71	73.7	80	80
	575	5.6	43	8.7	1.3	3.9	1.8	0	None	-	-	-	19.1	20.9	20	25
									E18	18	2	17.3	26.5	28.8	30	30
									E24	24	2	23.1	33.7	36	35	40
									E36	34	2	32.7	45.8	48	50	50
									E54	54	2	52.0	56.8	59.1	70	70
150 (12.5)	208	23.1	160	36	3.5	15.2	5.5	0	None	-	-	-	81.2	86.7	100	100
									E18	13.5	2	37.5	81.2	86.7	100	100
									E24	18	2	50.0	81.5	88.3	100	100
									E36	25.5	2	70.8	107.5	114.4	110	125
									E54	40.6	2	112.7	159.9	166.7	175	175
	230	23.1	160	36	3.5	15.2	5.5	0	None	-	-	-	81.2	86.7	100	100
									E18	18	2	43.3	81.2	86.7	100	100
									E24	24	2	57.7	91.2	98.0	100	100
									E36	34	2	81.8	121.2	128.1	125	150
									E54	54	2	129.9	148.9	155.8	175	175
	460	12.2	87	19	1.6	7.6	2.2	0	None	-	-	-	41.5	43.7	50	50
									E18	18	2	21.7	41.5	43.7	50	50
									E24	24	2	28.9	45.6	48.3	50	50
									E36	34	2	40.9	60.6	63.4	70	70
									E54	54	2	65.0	74.5	77.2	90	90
	575	8.7	62	13.5	1.3	6.1	1.8	0	None	-	-	-	30.9	32.7	35	40
									E18	18	2	17.3	30.9	32.7	35	40
									E24	24	2	23.1	36.5	38.7	40	40
									E36	34	2	32.7	48.5	50.8	50	60
									E54	54	2	52.0	59.6	61.8	70	70

1. Minimum Circuit Ampacity.
2. Dual Element, Time Delay Type.
3. HACR type per NEC.

ZF078-150 Standard Motor - With Powered Convenience Outlet

Size (Tons)	Volt	Compressors (each)			OD Fan Motors (each)	Supply Blower Motor	Pwr Exh Motor	Pwr Conv Outlet	Electric Heat Option				MCA ¹ (Amps)	MCA ¹ w/Pwr Exh (Amps)	Max Fuse ² / Breaker ³ Size (Amps)	Max Fuse ² / Breaker ³ Size w/ Pwr Exh (Amps)
		RLA	LRA	MCC	FLA	FLA	FLA	FLA	Model	kW	Stages	Amps				
078 (6.5)	208	9.3	68	14.5	1.5	6.0	5.5	10	None	-	-	-	40.1	45.6	50	50
									E09	6.8	1	18.9	43.6	50.5	50	60
									E18	13.5	2	37.5	66.8	73.7	70	80
									E24	18	2	50.0	82.5	89.3	90	90
									E36	25.5	2	70.8	108.5	115.4	110	125
	230	9.3	68	14.5	1.5	6.0	5.5	10	None	-	-	-	40.1	45.6	50	50
									E09	9	1	21.7	47.1	53.9	50	60
									E18	18	2	43.3	74.1	81	80	90
									E24	24	2	57.7	92.2	99	100	100
									E36	34	2	81.8	122.2	129.1	125	150
	460	4.9	34	7.7	0.8	3.0	2.2	5	None	-	-	-	20.7	22.9	25	25
									E09	9	1	10.8	23.5	26.3	25	30
									E18	18	2	21.7	37.1	39.8	40	40
									E24	24	2	28.9	46.1	48.8	50	50
									E36	34	2	40.9	61.1	63.9	70	70
	575	3.8	28	6	0.6	2.4	1.8	4	None	-	-	-	16.2	18	20	20
									E09	9	1	8.7	18.8	21.1	20	25
									E18	18	2	17.3	29.7	31.9	30	35
									E24	24	2	23.1	36.9	39.1	40	40
									E36	34	2	32.7	48.9	51.1	50	60
090 (7.5)	208	11.9	88	18.5	3.5	6.0	5.5	10	None	-	-	-	49.8	55.3	60	60
									E09	6.8	1	18.9	49.8	55.3	60	60
									E18	13.5	2	37.5	66.8	73.7	70	80
									E24	18	2	50.0	82.5	89.3	90	90
									E36	25.5	2	70.8	108.5	115.4	110	125
	230	11.9	88	18.5	3.5	6.0	5.5	10	None	-	-	-	49.8	55.3	60	60
									E09	9	1	21.7	49.8	55.3	60	60
									E18	18	2	43.3	74.1	81	80	90
									E24	24	2	57.7	92.2	99	100	100
									E36	34	2	81.8	122.2	129.1	125	150
	460	5.2	44	8.1	1.6	3.0	2.2	5	None	-	-	-	22.9	25.1	25	30
									E09	9	1	10.8	23.5	26.3	25	30
									E18	18	2	21.7	37.1	39.8	40	40
									E24	24	2	28.9	46.1	48.8	50	50
									E36	34	2	40.9	61.1	63.9	70	70
	575	4.8	36	7.5	1.3	2.4	1.8	4	None	-	-	-	19.8	21.6	20	25
									E09	9	1	8.7	19.8	21.6	20	25
									E18	18	2	17.3	29.7	31.9	30	35
									E24	24	2	23.1	36.9	39.1	40	40
									E36	34	2	32.7	48.9	51.1	50	60
102 (8.5)	208	12.2	88	19	3.5	6.8	5.5	10	None	-	-	-	51.3	56.8	60	60
									E09	6.8	1	18.9	51.3	56.8	60	60
									E18	13.5	2	37.5	67.8	74.7	70	80
									E24	18	2	50.0	83.5	90.3	90	100
									E36	25.5	2	70.8	109.5	116.4	110	125
	230	12.2	88	19	3.5	6.8	5.5	10	None	-	-	-	51.3	56.8	60	60
									E09	9	1	21.7	51.3	56.8	60	60
									E18	18	2	43.3	75.1	82	80	90
									E24	24	2	57.7	93.2	100	100	100
									E36	34	2	81.8	123.2	130.1	125	150
	460	5.8	44	9	1.6	3.4	2.2	5	None	-	-	-	24.7	26.9	30	30
									E09	9	1	10.8	24.7	26.9	30	30
									E18	18	2	21.7	37.6	40.3	40	45
									E24	24	2	28.9	46.6	49.3	50	50
									E36	34	2	40.9	61.6	64.4	70	70
	575	4.4	36	5.5	1.3	2.7	1.8	4	None	-	-	-	19.2	21	20	25
									E09	9	1	8.7	19.2	21.5	20	25
									E18	18	2	17.3	30	32.3	30	35
									E24	24	2	23.1	37.2	39.5	40	40
									E36	34	2	32.7	49.3	51.5	50	60

ZF078-150 Standard Motor - With Powered Convenience Outlet (Continued)

Size (Tons)	Volt	Compressors (each)			OD Fan Motors (each)	Supply Blower Motor	Pwr Exh Motor	Pwr Conv Outlet	Electric Heat Option				MCA ¹ (Amps)	MCA ¹ w/Pwr Exh (Amps)	Max Fuse ² / Breaker ³ Size (Amps)	Max Fuse ² / Breaker ³ Size w/ Pwr Exh (Amps)
		RLA	LRA	MCC	FLA	FLA	FLA	FLA	Model	kW	Stages	Amps				
120 (10)	208	13.9	110	21.7	3.5	6.8	5.5	10	None	-	-	-	55.1	60.6	60	70
									E18	13.5	2	37.5	67.8	74.7	70	80
									E24	18	2	50.0	83.5	90.3	90	100
									E36	25.5	2	70.8	109.5	116.4	110	125
									E54	40.6	2	112.7	161.9	168.7	175	175
	230	13.9	110	21.7	3.5	6.8	5.5	10	None	-	-	-	55.1	60.6	60	70
									E18	18	2	43.3	75.1	82	80	90
									E24	24	2	57.7	93.2	100	100	100
									E36	34	2	81.8	123.2	130.1	125	150
									E54	54	2	129.9	150.9	157.8	175	175
	460	7.4	55	11.5	1.6	3.4	2.2	5	None	-	-	-	28.3	30.5	35	35
									E18	18	2	21.7	37.6	40.3	40	45
									E24	24	2	28.9	46.6	49.3	50	50
									E36	34	2	40.9	61.6	64.4	70	70
									E54	54	2	65.0	75.5	78.2	80	90
	575	5.6	43	8.7	1.3	2.7	1.8	4	None	-	-	-	21.9	23.7	25	25
									E18	18	2	17.3	30	32.3	30	35
									E24	24	2	23.1	37.2	39.5	40	40
									E36	34	2	32.7	49.3	51.5	50	60
									E54	54	2	52.0	60.3	62.6	70	70
150 (12.5)	208	23.1	160	36	3.5	9.6	5.5	10	None	-	-	-	85.6	91.1	100	110
									E18	13.5	2	37.5	85.6	91.1	100	110
									E24	18	2	50.0	87.0	93.8	100	110
									E36	25.5	2	70.8	113.0	119.9	125	125
									E54	40.6	2	112.7	165.4	172.2	175	175
	230	23.1	160	36	3.5	9.6	5.5	10	None	-	-	-	85.6	91.1	100	110
									E18	18	2	43.3	85.6	91.1	100	110
									E24	24	2	57.7	96.7	103.5	100	110
									E36	34	2	81.8	126.7	133.6	150	150
									E54	54	2	129.9	154.4	161.3	175	175
	460	12.2	87	19	1.6	4.8	2.2	5	None	-	-	-	43.7	45.9	50	50
									E18	18	2	21.7	43.7	45.9	50	50
									E24	24	2	28.9	48.3	51.1	50	60
									E36	34	2	40.9	63.4	66.1	70	70
									E54	54	2	65.0	77.2	80.0	90	90
	575	8.7	62	13.5	1.3	3.9	1.8	4	None	-	-	-	32.7	34.5	40	40
									E18	18	2	17.3	32.7	34.5	40	40
									E24	24	2	23.1	38.7	41.0	40	45
									E36	34	2	32.7	50.8	53.0	60	60
									E54	54	2	52.0	61.8	64.1	70	70

1. Minimum Circuit Ampacity.
2. Dual Element, Time Delay Type.
3. HACR type per NEC.

ZF078-150 Hi Static Motor - With Powered Convenience Outlet

Size (Tons)	Volt	Compressors (each)			OD Fan Motors (each)	Supply Blower Motor	Pwr Exh Motor	Pwr Conv Outlet	Electric Heat Option				MCA ¹ (Amps)	MCA ¹ w/Pwr Exh (Amps)	Max Fuse ² / Breaker ³ (Amps)	Max Fuse ² / Breaker ³ Size w/ Pwr Exh (Amps)
		RLA	LRA	MCC	FLA	FLA	FLA	FLA	Model	kW	Stages	Amps				
078 (6.5)	208	9.3	68	14.5	1.5	6.8	5.5	10	None	-	-	-	40.9	46.4	50	50
									E09	6.8	1	18.9	44.6	51.5	50	60
									E18	13.5	2	37.5	67.8	74.7	70	80
									E24	18	2	50.0	83.5	90.3	90	100
									E36	25.5	2	70.8	109.5	116.4	110	125
	230	9.3	68	14.5	1.5	6.8	5.5	10	None	-	-	-	40.9	46.4	50	50
									E09	9	1	21.7	48.1	54.9	50	60
									E18	18	2	43.3	75.1	82	80	90
									E24	24	2	57.7	93.2	100	100	100
									E36	34	2	81.8	123.2	130.1	125	150
	460	4.9	34	7.7	0.8	3.4	2.2	5	None	-	-	-	21.1	23.3	25	25
									E09	9	1	10.8	24	26.8	25	30
									E18	18	2	21.7	37.6	40.3	40	45
									E24	24	2	28.9	46.6	49.3	50	50
									E36	34	2	40.9	61.6	64.4	70	70
	575	3.8	28	6	0.6	2.7	1.8	4	None	-	-	-	16.5	18.3	20	20
									E09	9	1	8.7	19.2	21.5	20	25
									E18	18	2	17.3	30	32.3	30	35
									E24	24	2	23.1	37.2	39.5	40	40
									E36	34	2	32.7	49.3	51.5	50	60
090 (7.5)	208	11.9	88	18.5	3.5	9.6	5.5	10	None	-	-	-	53.4	58.9	60	70
									E09	6.8	1	18.9	53.4	58.9	60	70
									E18	13.5	2	37.5	71.3	78.2	80	80
									E24	18	2	50.0	87	93.8	90	100
									E36	25.5	2	70.8	113	119.9	125	125
	230	11.9	88	18.5	3.5	9.6	5.5	10	None	-	-	-	53.4	58.9	60	70
									E09	9	1	21.7	53.4	58.9	60	70
									E18	18	2	43.3	78.6	85.5	80	90
									E24	24	2	57.7	96.7	103.5	100	110
									E36	34	2	81.8	126.7	133.6	150	150
	460	5.2	44	8.1	1.6	4.8	2.2	5	None	-	-	-	24.7	26.9	25	30
									E09	9	1	10.8	25.8	28.5	30	30
									E18	18	2	21.7	39.3	42.1	40	45
									E24	24	2	28.9	48.3	51.1	50	60
									E36	34	2	40.9	63.4	66.1	70	70
	575	4.8	36	7.5	1.3	3.9	1.8	4	None	-	-	-	21.3	23.1	25	25
									E09	9	1	8.7	21.3	23.1	25	25
									E18	18	2	17.3	31.5	33.8	35	35
									E24	24	2	23.1	38.7	41	40	45
									E36	34	2	32.7	50.8	53	60	60
102 (8.5)	208	12.2	88	19	3.5	9.6	5.5	10	None	-	-	-	54.1	59.6	60	70
									E09	6.8	1	18.9	54.1	59.6	60	70
									E18	13.5	2	37.5	71.3	78.2	80	80
									E24	18	2	50.0	87	93.8	90	100
									E36	25.5	2	70.8	113	119.9	125	125
	230	12.2	88	19	3.5	9.6	5.5	10	None	-	-	-	54.1	59.6	60	70
									E09	9	1	21.7	54.1	59.6	60	70
									E18	18	2	43.3	78.6	85.5	80	90
									E24	24	2	57.7	96.7	103.5	100	110
									E36	34	2	81.8	126.7	133.6	150	150
	460	5.8	44	9	1.6	4.8	2.2	5	None	-	-	-	26.1	28.3	30	30
									E09	9	1	10.8	26.1	28.5	30	30
									E18	18	2	21.7	39.3	42.1	40	45
									E24	24	2	28.9	48.3	51.1	50	60
									E36	34	2	40.9	63.4	66.1	70	70
	575	4.4	36	5.5	1.3	3.9	1.8	4	None	-	-	-	20.4	22.2	25	25
									E09	9	1	8.7	20.7	23	25	25
									E18	18	2	17.3	31.5	33.8	35	35
									E24	24	2	23.1	38.7	41	40	45
									E36	34	2	32.7	50.8	53	60	60

ZF078-150 Hi Static Motor - With Powered Convenience Outlet (Continued)

Size (Tons)	Volt	Compressors (each)			OD Fan Motors (each)	Supply Blower Motor	Pwr Exh Motor	Pwr Conv Outlet	Electric Heat Option				MCA ¹ (Amps)	MCA ¹ w/Pwr Exh (Amps)	Max Fuse ² / Breaker ³ Size (Amps)	Max Fuse ² / Breaker ³ Size w/ Pwr Exh (Amps)
		RLA	LRA	MCC	FLA	FLA	FLA	FLA	Model	kW	Stages	Amps				
120 (10)	208	13.9	110	21.7	3.5	9.6	5.5	10	None	-	-	-	57.9	63.4	70	70
									E18	13.5	2	37.5	71.3	78.2	80	80
									E24	18	2	50.0	87	93.8	90	100
									E36	25.5	2	70.8	113	119.9	125	125
									E54	40.6	2	112.7	165.4	172.2	175	175
	230	13.9	110	21.7	3.5	9.6	5.5	10	None	-	-	-	57.9	63.4	70	70
									E18	18	2	43.3	78.6	85.5	80	90
									E24	24	2	57.7	96.7	103.5	100	110
									E36	34	2	81.8	126.7	133.6	150	150
									E54	54	2	129.9	154.4	161.3	175	175
	460	7.4	55	11.5	1.6	4.8	2.2	5	None	-	-	-	29.7	31.9	35	35
									E18	18	2	21.7	39.3	42.1	40	45
									E24	24	2	28.9	48.3	51.1	50	60
									E36	34	2	40.9	63.4	66.1	70	70
									E54	54	2	65.0	77.2	80	90	90
	575	5.6	43	8.7	1.3	3.9	1.8	4	None	-	-	-	23.1	24.9	25	30
									E18	18	2	17.3	31.5	33.8	35	35
									E24	24	2	23.1	38.7	41	40	45
									E36	34	2	32.7	50.8	53	60	60
									E54	54	2	52.0	61.8	64.1	70	70
150 (12.5)	208	23.1	160	36	3.5	15.2	5.5	10	None	-	-	-	91.2	96.7	110	110
									E18	13.5	2	37.5	91.2	96.7	110	110
									E24	18	2	50.0	94.0	100.8	110	110
									E36	25.5	2	70.8	120.0	126.9	125	150
									E54	40.6	2	112.7	172.4	179.2	175	200
	230	23.1	160	36	3.5	15.2	5.5	10	None	-	-	-	91.2	96.7	110	110
									E18	18	2	43.3	91.2	96.7	110	110
									E24	24	2	57.7	103.7	110.5	110	125
									E36	34	2	81.8	133.7	140.6	150	150
									E54	54	2	129.9	161.4	168.3	175	175
	460	12.2	87	19	1.6	7.6	2.2	5	None	-	-	-	46.5	48.7	50	60
									E18	18	2	21.7	46.5	48.7	50	60
									E24	24	2	28.9	51.8	54.6	60	60
									E36	34	2	40.9	66.9	69.6	70	70
									E54	54	2	65.0	80.7	83.5	90	90
	575	8.7	62	13.5	1.3	6.1	1.8	4	None	-	-	-	34.9	36.7	40	45
									E18	18	2	17.3	34.9	36.7	40	45
									E24	24	2	23.1	41.5	43.7	45	45
									E36	34	2	32.7	53.5	55.8	60	60
									E54	54	2	52.0	64.6	66.8	70	70

1. Minimum Circuit Ampacity.
2. Dual Element, Time Delay Type.
3. HACR type per NEC.

Typical Wiring Diagrams

ZF078-150 Typical Wiring Diagrams

Typical ZF078-120 Cooling Unit with Gas Heat 230 Volt Wiring Diagram

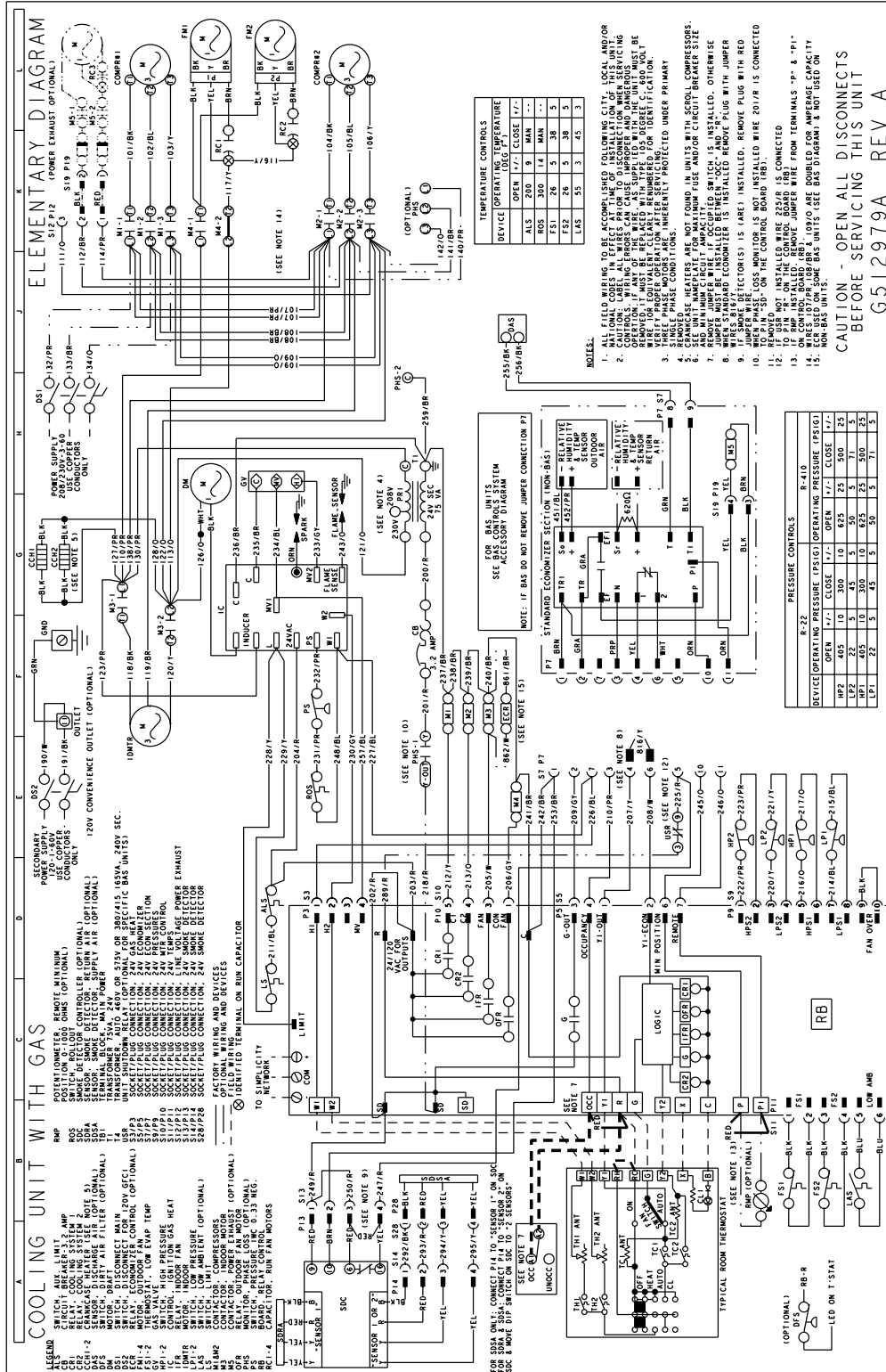

Typical ZF078-120 Cooling Unit with Gas Heat 460/575 Volt Wiring Diagram

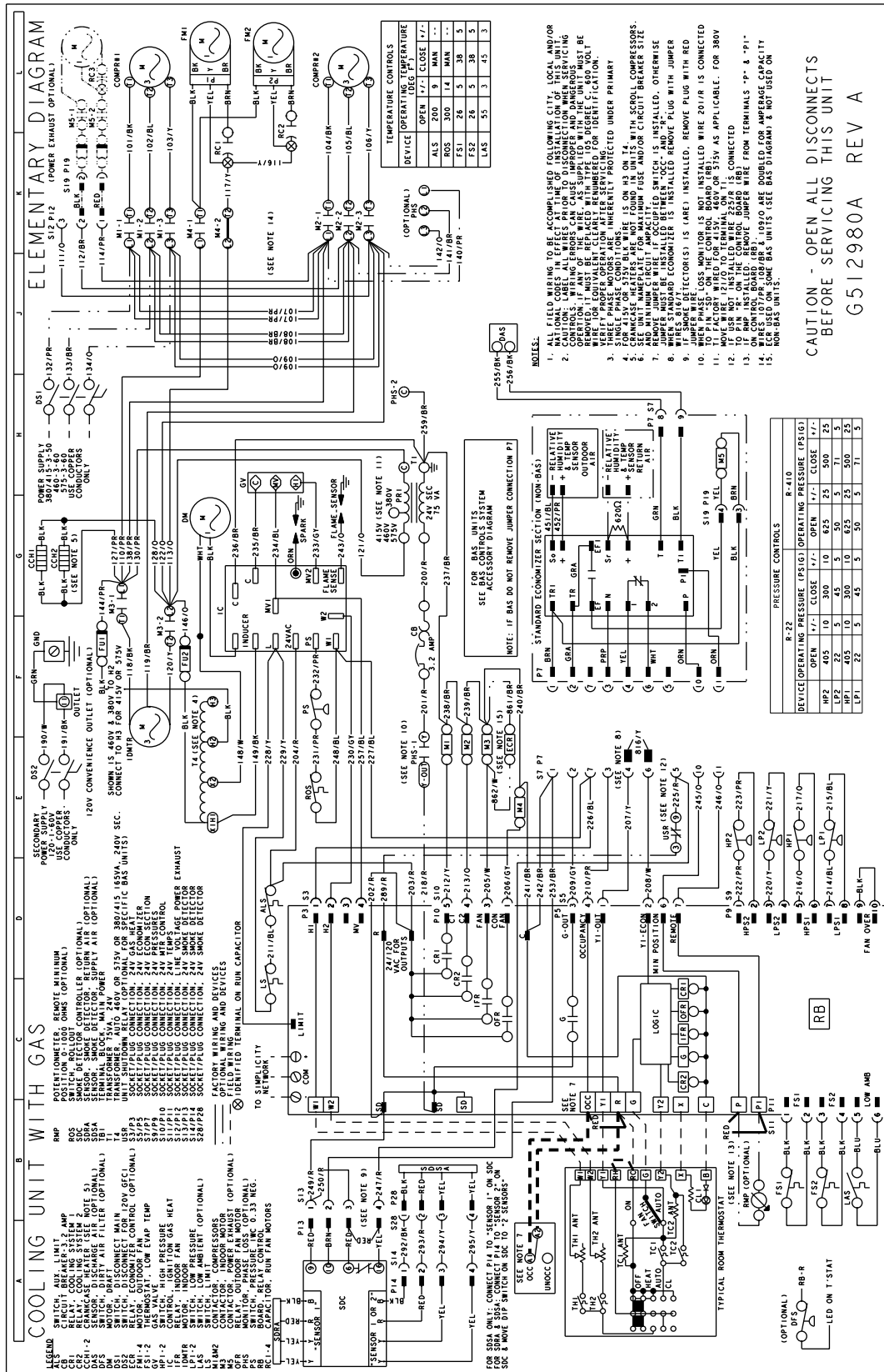

Typical ZF078-120 Cooling Unit with/without Electric Heat Wiring

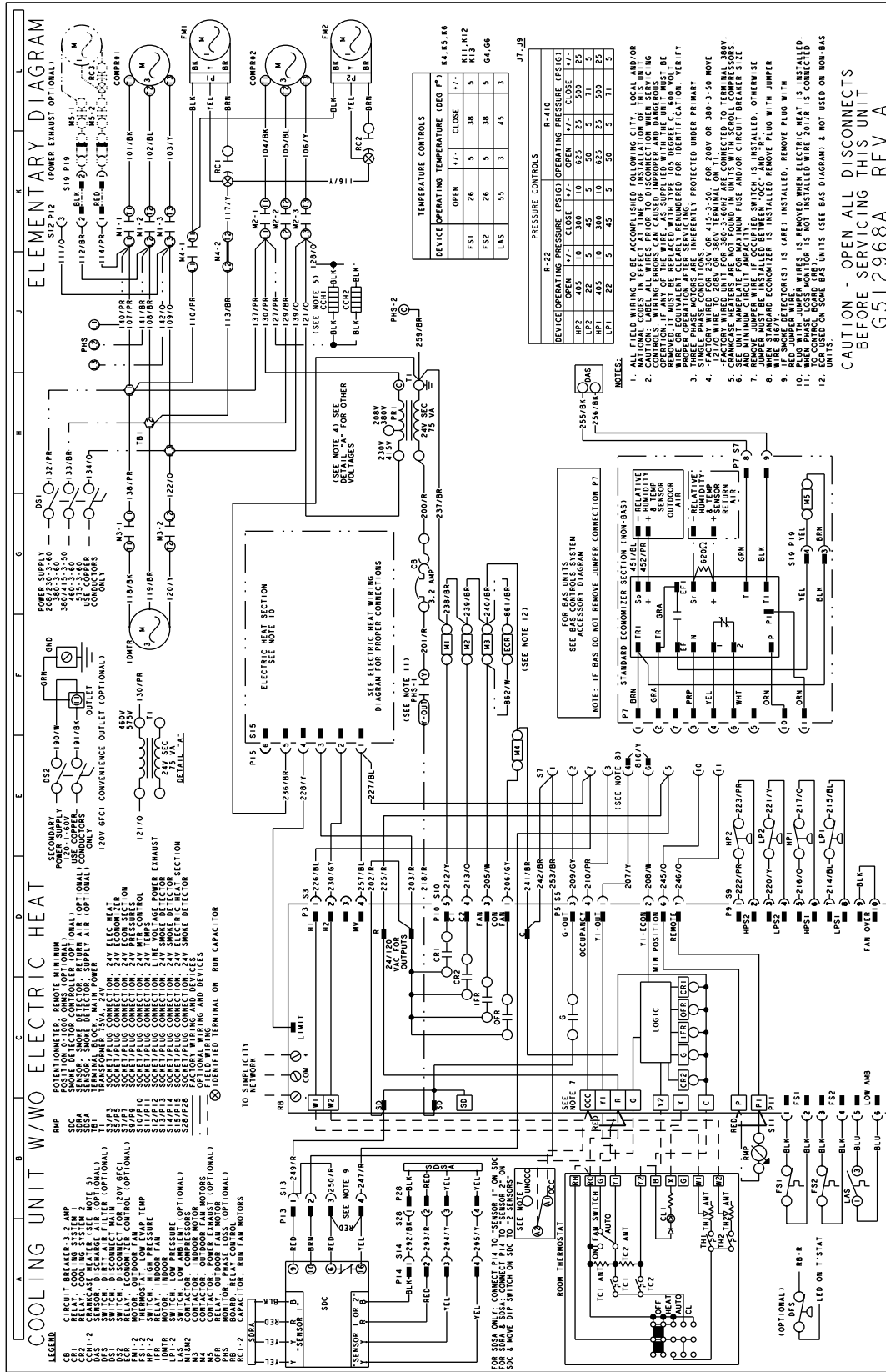

Typical ZF150 Cooling Unit with Gas Heat 230 Volt Wiring Diagram

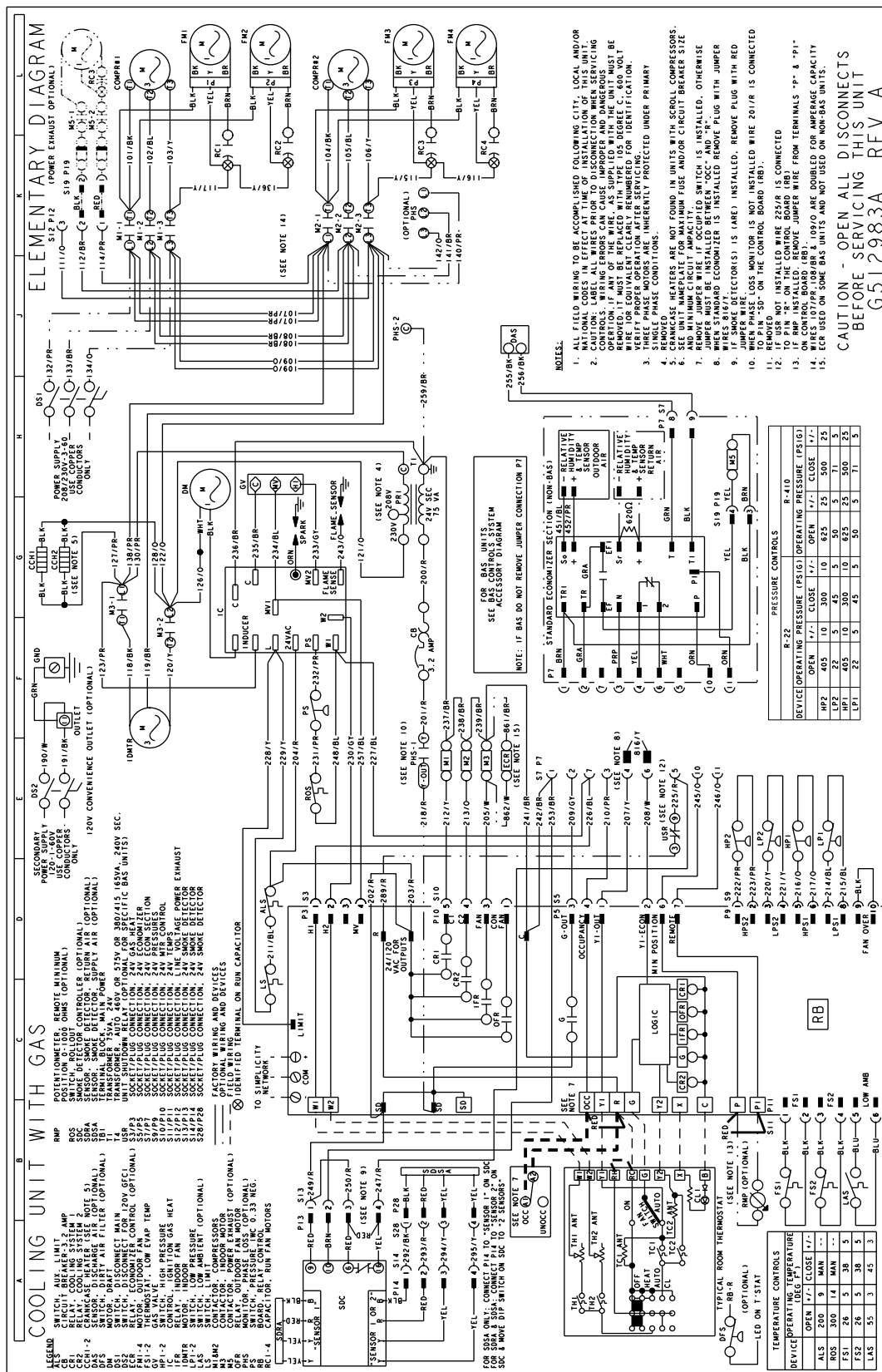

NOTES:

- ALL FIELD WIRING TO BE ACCOMPLISHED FOLLOWING CITY, LOCAL AND/OR NATIONAL CODES IN EFFECT AT TIME OF INSTALLATION OF THIS UNIT.
- CONTROL WIRING ERRORS CAN CAUSE IMPROPER AND DANGEROUS OPERATION. IF ANY OF THE WIRING WAS SUPPLIED WITH THE UNIT, IT MUST BE CORRECTED TO THE EQUIVALENT WIRING FOR THE UNIT. THE EQUIVALENT WIRE FOR EQUIVALENT CLEARLY RENUMBERED FOR IDENTIFICATION.
- VERIFY PROPER OPERATION AFTER SERVICING.
- REMOVE HEATERS ARE NOT FOUND IN UNITS WITH SCROLL COMPRESSORS.
- SEE UNIT NAMEPLATE FOR MAXIMUM USE AND/OR CIRCUIT BREAKER SIZE.
- REMOVING JUMPER FOR "OCC" AND "R".
- JUMPER MUST BE INSTALLED BETWEEN "OCC" AND "R".
- WHEN STANDARD ECONOMIZER IS INSTALLED REMOVE PLUG WITH JUMPER TO PIN "SD" ON THE CONTROL BOARD (RB).
- IF USED NOT INSTALLED WIRE 252/R IS CONNECTED TO PIN "R" ON THE CONTROL BOARD (RB).
- ON CONTROL BOARD (RB) JUMPER WIRE FROM TERMINALS "P" & "P1" WIRE 107/PR, 108/BR & 109/O ARE DOUBLED FOR AMPERAGE CAPACITY.
- TCR USED ON SOME GAS UNITS AND NOT USED ON NON-GAS UNITS.

TEMPERATURE CONTROLS

DEVICE	OPERATING PRESSURE (PSIG)	OPERATING PRESSURE (PSIG)	OPERATING PRESSURE (PSIG)	OPERATING PRESSURE (PSIG)
WP2	OPEN 1/7	CLOSE 1/7	OPEN 1/7	CLOSE 1/7
WP2	405	10	300	10
WP2	405	10	300	10
WP2	405	10	300	10
WP2	405	10	300	10
WP2	405	10	300	10
WP2	405	10	300	10

PHASE LOSS MONITOR

R-22	OPERATING PRESSURE (PSIG)	OPERATING PRESSURE (PSIG)	OPERATING PRESSURE (PSIG)	OPERATING PRESSURE (PSIG)
WP2	OPEN 1/7	CLOSE 1/7	OPEN 1/7	CLOSE 1/7
WP2	405	10	300	10
WP2	405	10	300	10
WP2	405	10	300	10
WP2	405	10	300	10
WP2	405	10	300	10
WP2	405	10	300	10
WP2	405	10	300	10

CONTROL BOARD (RB)

WIRING

COMPRESSOR

FAN

VALVES

RELAYS

CONTACTORS

CAPACITORS

SENSORS

TERMINALS

PHASE LOSS MONITOR

PHASE LOSS SWITCH

PHASE LOSS CAPACITORS

GAUSS - OPEN ALL THIS UNIT BEFORE SERVICING THIS UNIT G512983A REV A

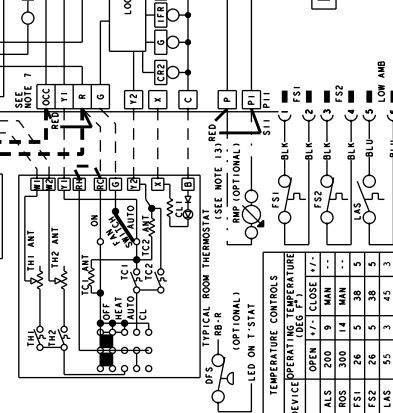
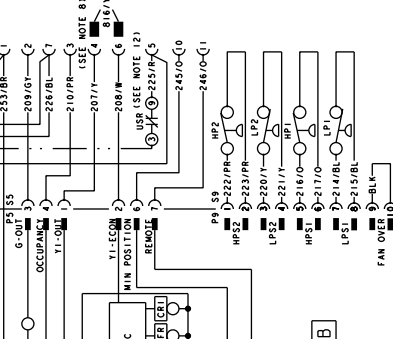
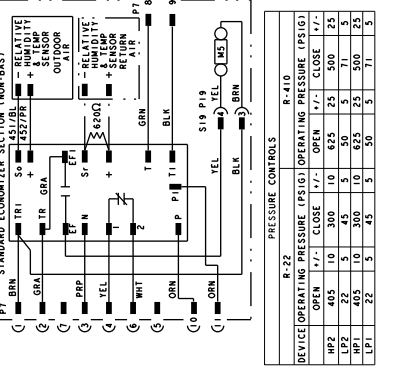

Typical ZF150 Cooling Unit with Gas Heat 460/575 Volt Wiring Diagram

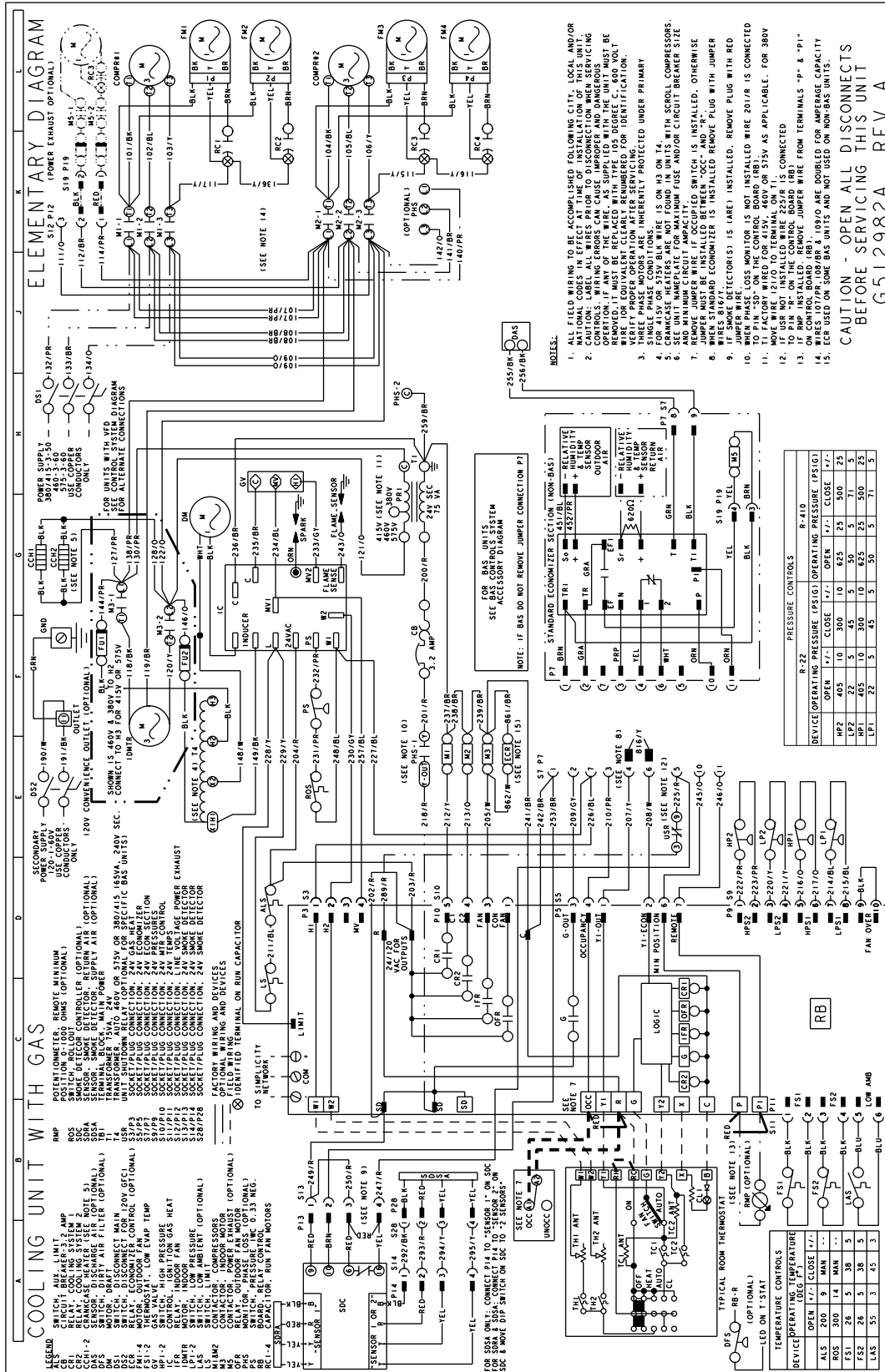

Typical ZF078-150 Factory Installed VFD (Option)

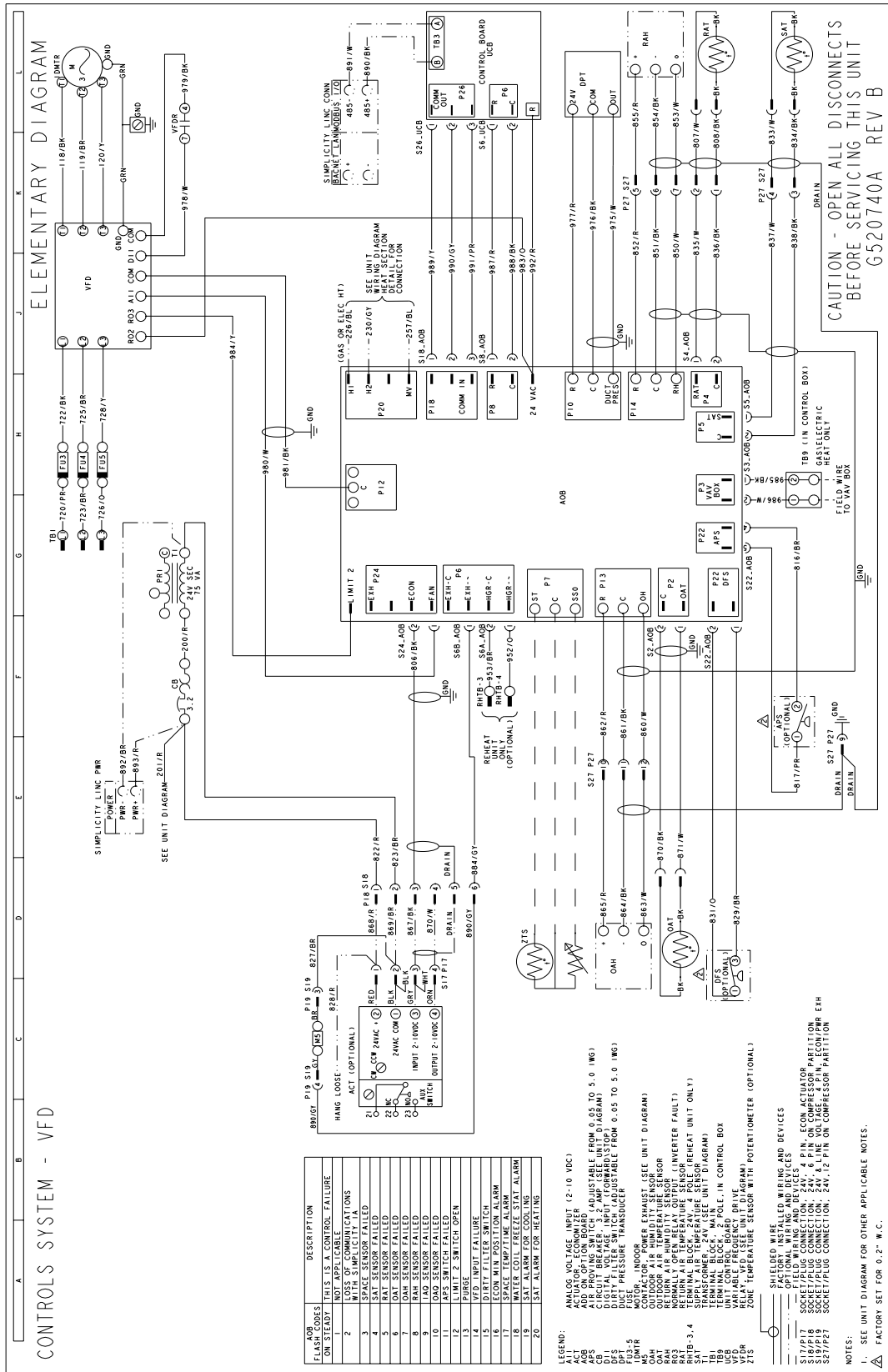

Typical ZF078-150 Factory Installed VFD with Manual Bypass (Option)

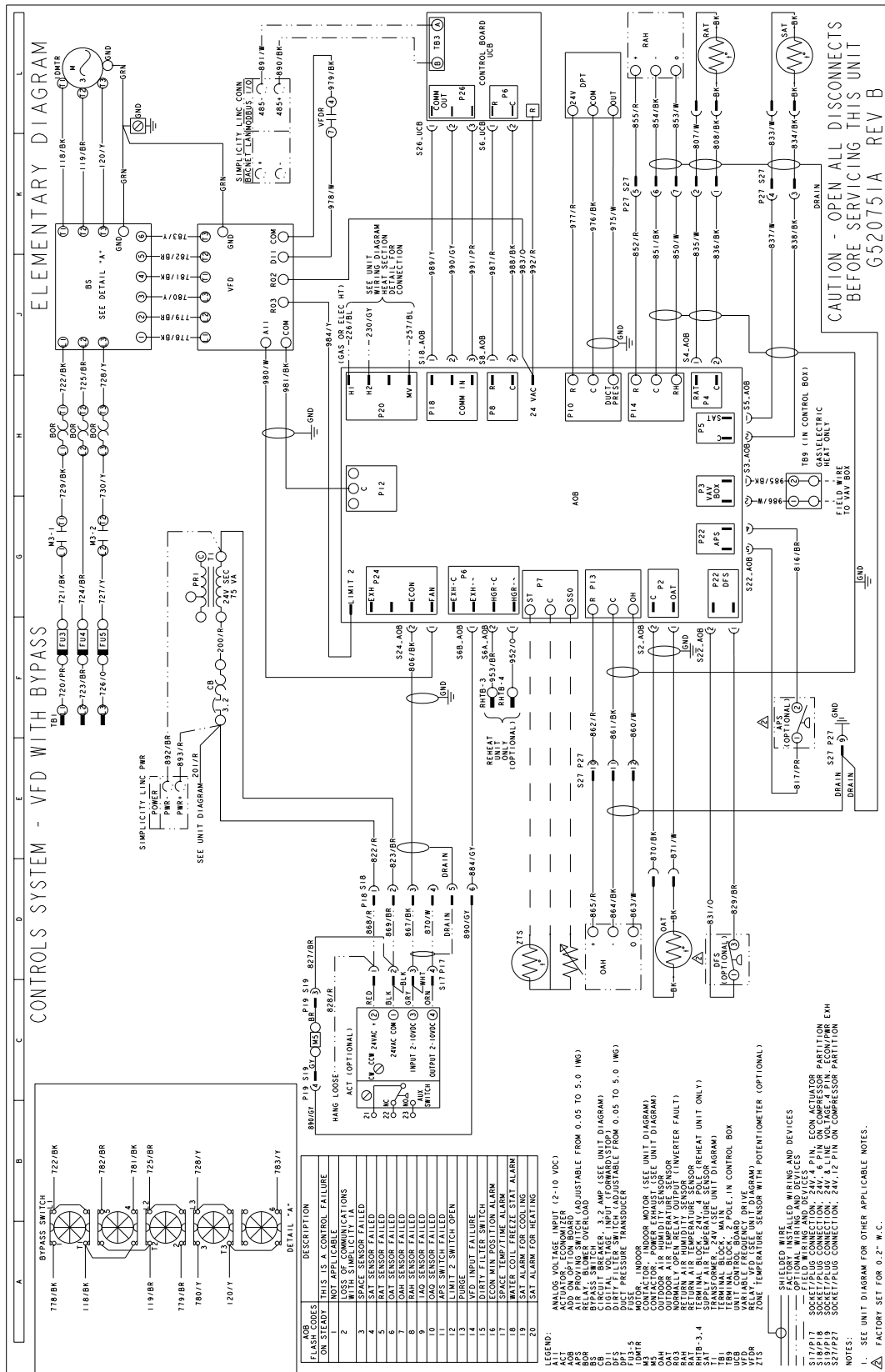

Typical ZF078-150 Factory Installed VFD with CCS Control (Option)

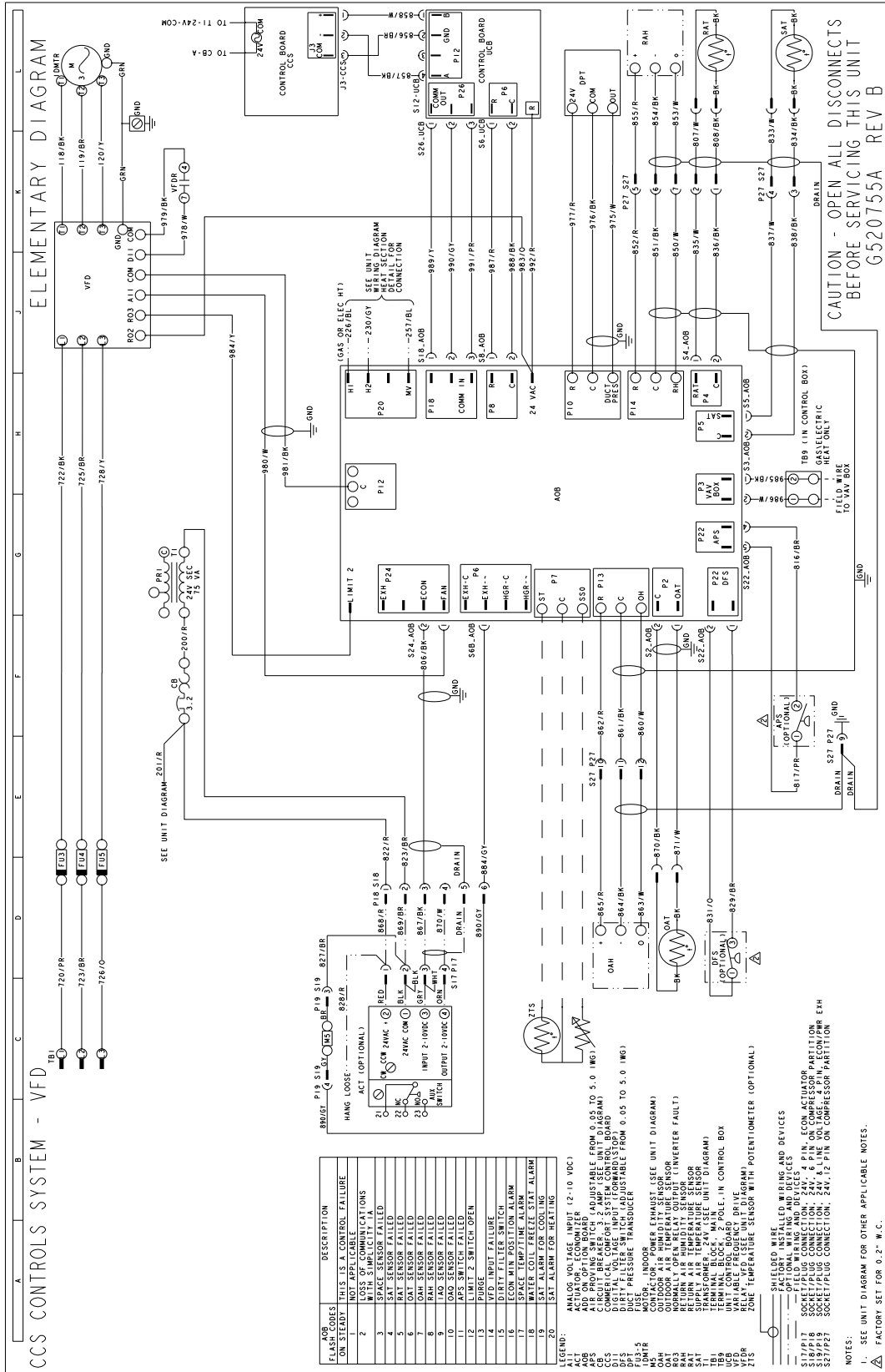

Typical ZF078-150 Factory Installed VFD and Manual Bypass with CCS Control (Option)

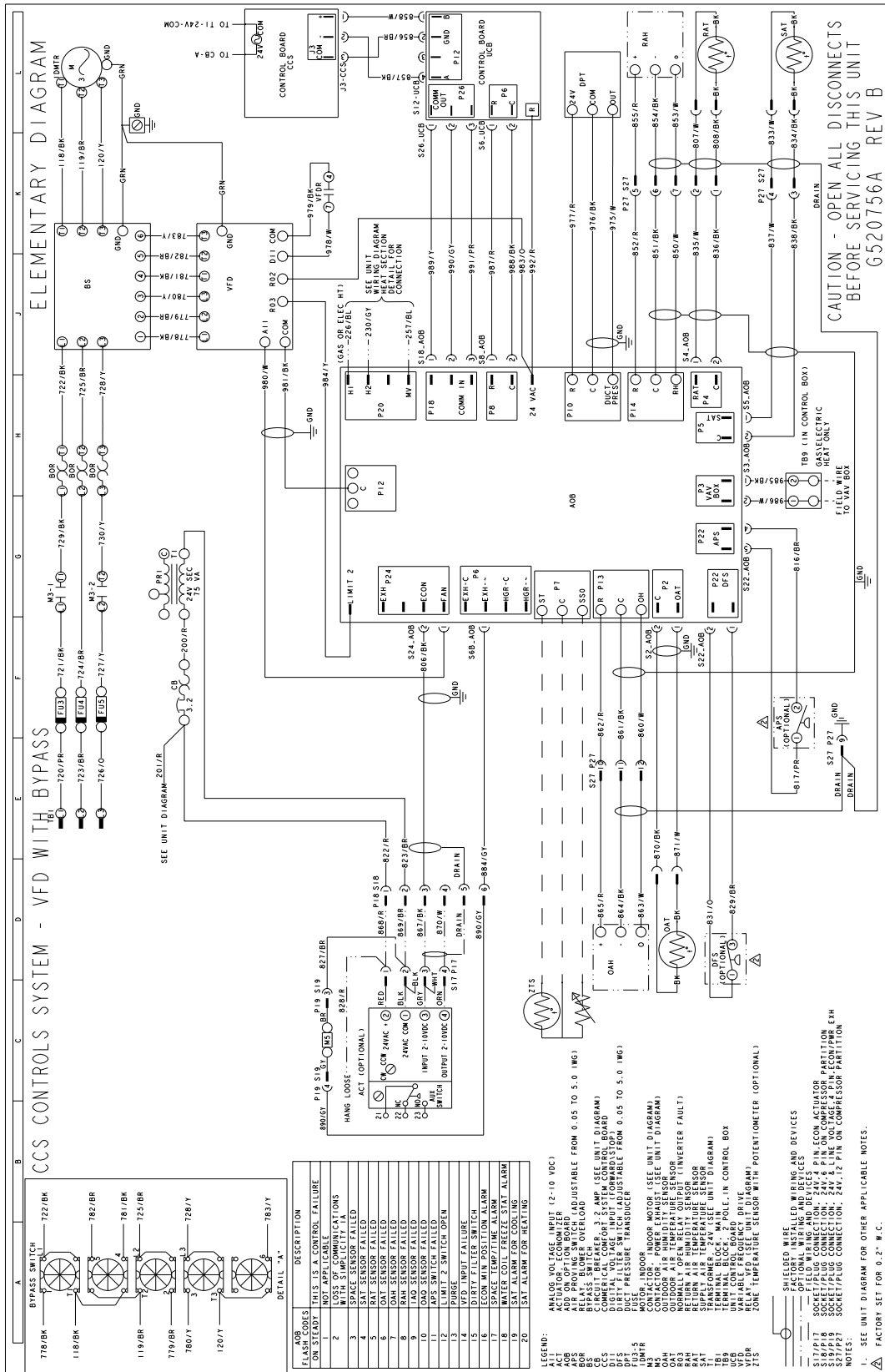

Typical ZF078-150 BAS Ready Unit with Factory Installed VFD (Option)

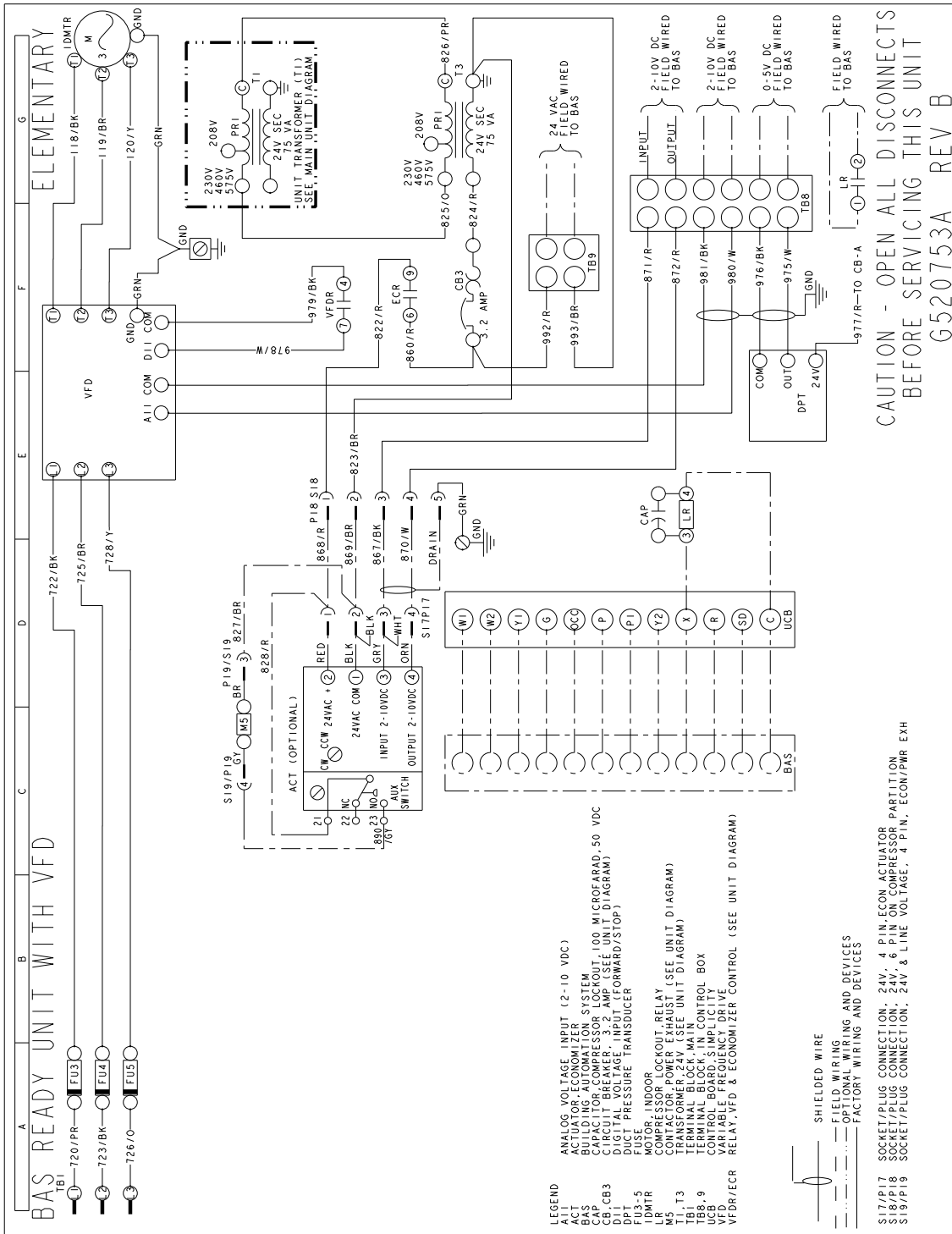

Typical ZF078-150 BAS Ready Unit with Factory Installed VFD and Manual Bypass (Option)

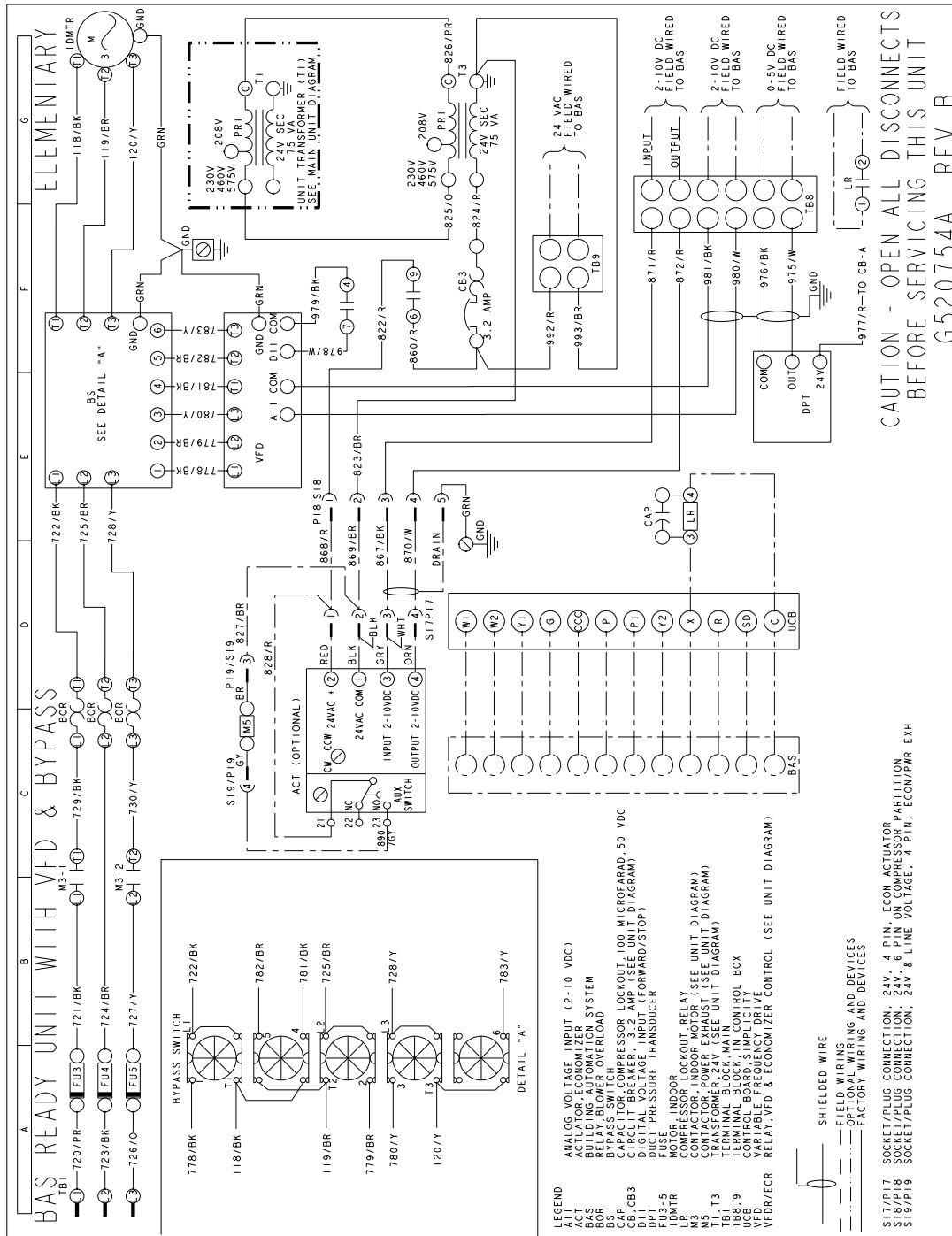

Typical ZF078-150 VFD Ready Unit (Option)

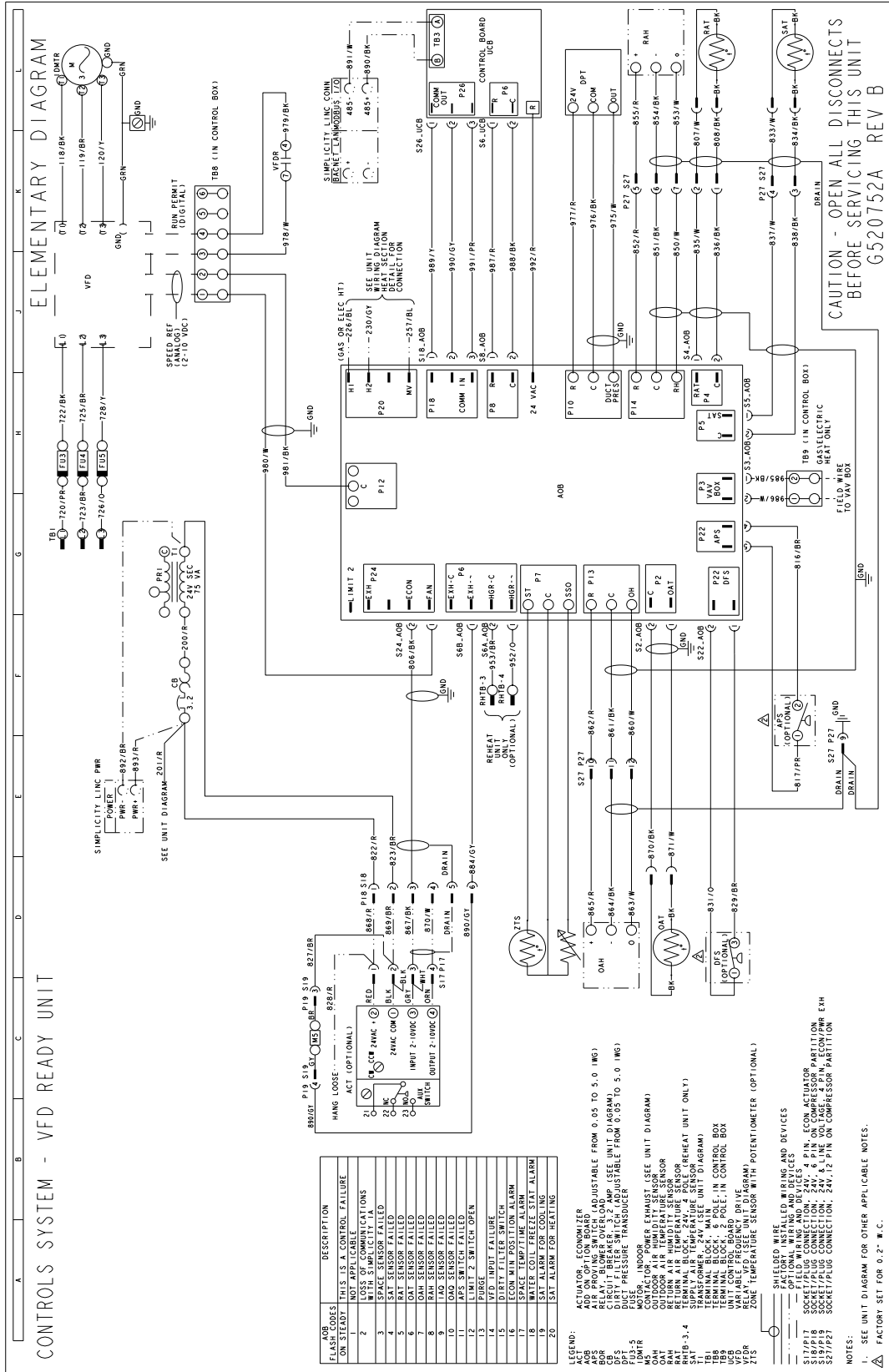

Weights and Dimensions

ZF078-150 Unit Weights

Unit 4 Point Load Weight

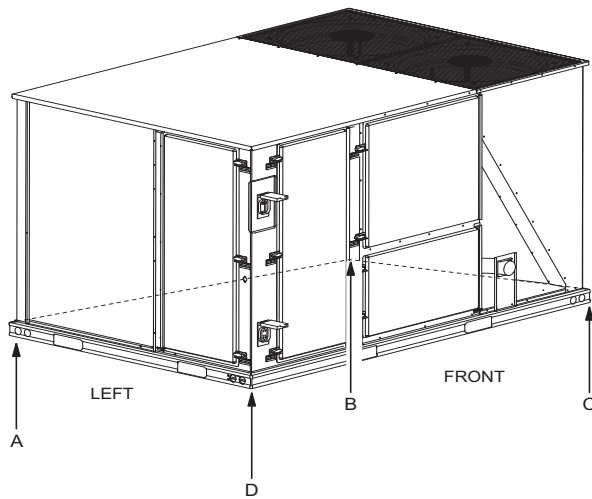

Unit 6 Point Load Weight

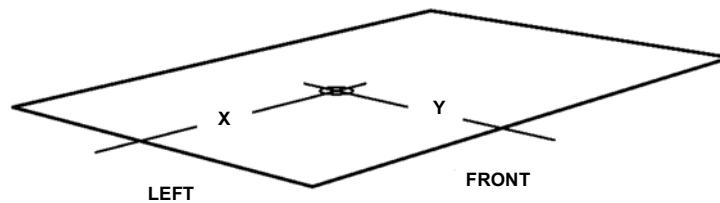
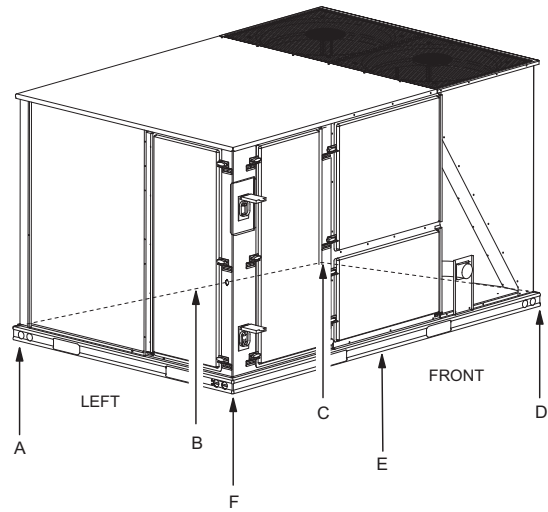

Size (Tons)	Model	Weight (lbs.)		Center of Gravity		4 Point Load Location (lbs.)				6 Point Load Location (lbs.)					
		Shipping	Operating	X	Y	A	B	C	D	A	B	C	D	E	F
078 (6.5)	ZF	865	860	38	24	200	149	218	292	140	114	95	138	167	205
090 (7.5)	ZF	885	860	38	24	205	153	223	299	144	117	97	142	171	210
102 (8.5)	ZF	1025	1020	38	24	238	177	258	347	167	136	113	164	198	243
120 (10)	ZF	1065	1060	38	24	247	184	268	360	173	141	117	171	206	253
150 (12.5)	ZF	1258	1253	47	25	251	280	381	341	164	176	190	259	240	223

ZF078-150 Unit Accessory Weights

Unit Accessory	Weight (lbs.)	
	Shipping	Operating
Economizer	90	85
Power Exhaust	40	35
Electric Heat ¹	49	49
Gas Heat ²	110	110
Variable Frequency Drive ³	30	30

1. Weight given is for the maximum heater size available (54KW).
2. Weight given is for the maximum number of tube heat exchangers available (8 tube).
3. Weight includes mounting hardware, controls and manual bypass option (ZF Only).

ZF078-150 Unit Dimensions

ZF078 - 120

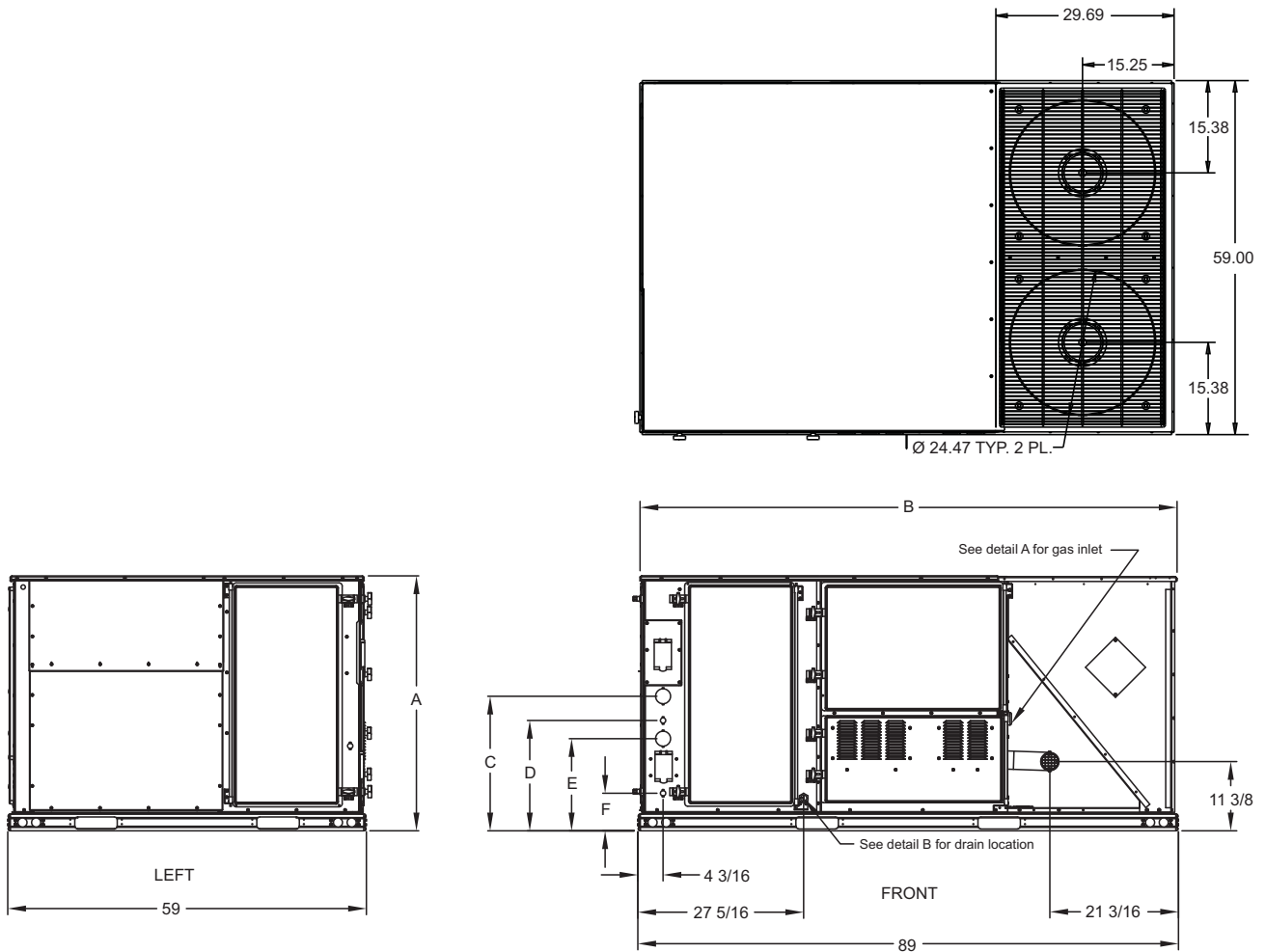

ZF150

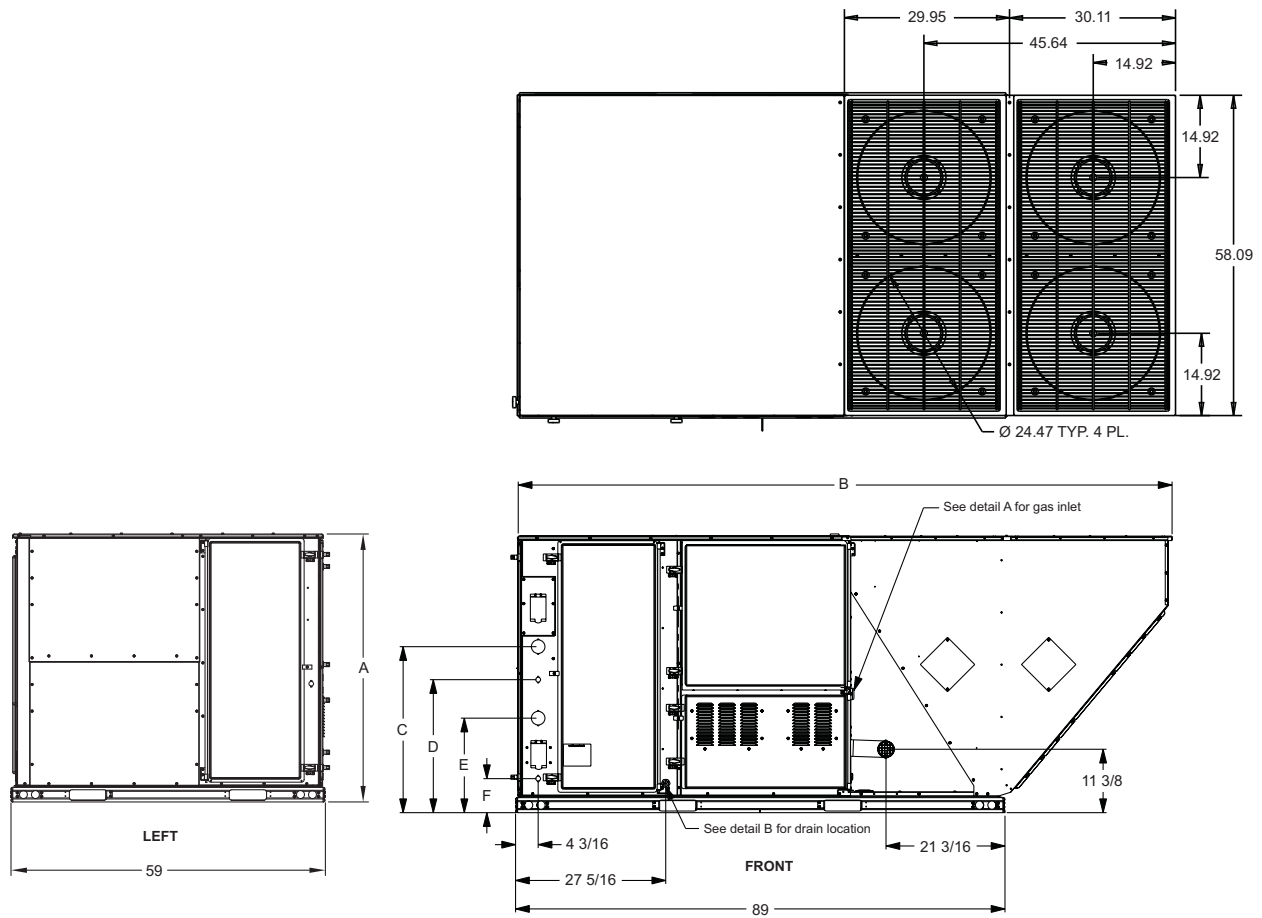

ZF078-150 Unit Physical Dimensions

Unit Model Number	Dimension (in.)					
	A	B	C	D	E	F
078	42	89	22 1/8	18 3/16	15 3/16	6 3/16
090	42	89	22 1/8	18 3/16	15 3/16	6 3/16
102	50 3/4	89	30 3/16	24 3/16	17 3/16	6 3/16
120	50 3/4	89	30 3/16	24 3/16	17 3/16	6 3/16
150	50 3/4	119 1/2	30 3/16	24 3/16	17 3/16	6 3/16

Detail A

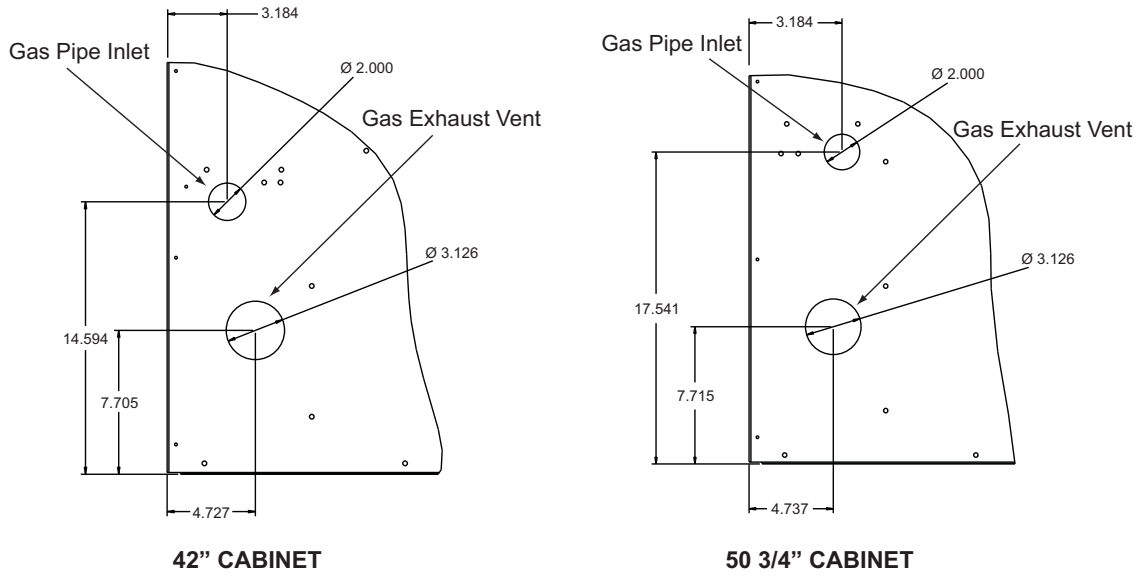

Detail B

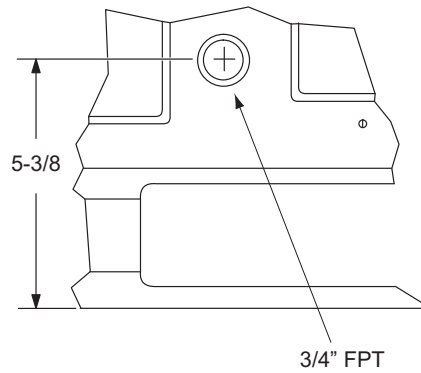

ZF078-150 Unit Clearances

Direction	Distance (in.)	Direction	Distance (in.)
Top ¹	72	Right	12
Front	36	Left	36
Rear	36	Bottom ²	0

1. Units must be installed outdoors. Over hanging structure or shrubs should not obscure condenser air discharge outlet.
2. Units may be installed on combustible floors made from wood or class A, B or C roof covering materials.

ZF078-150 Unit Bottom Duct Openin

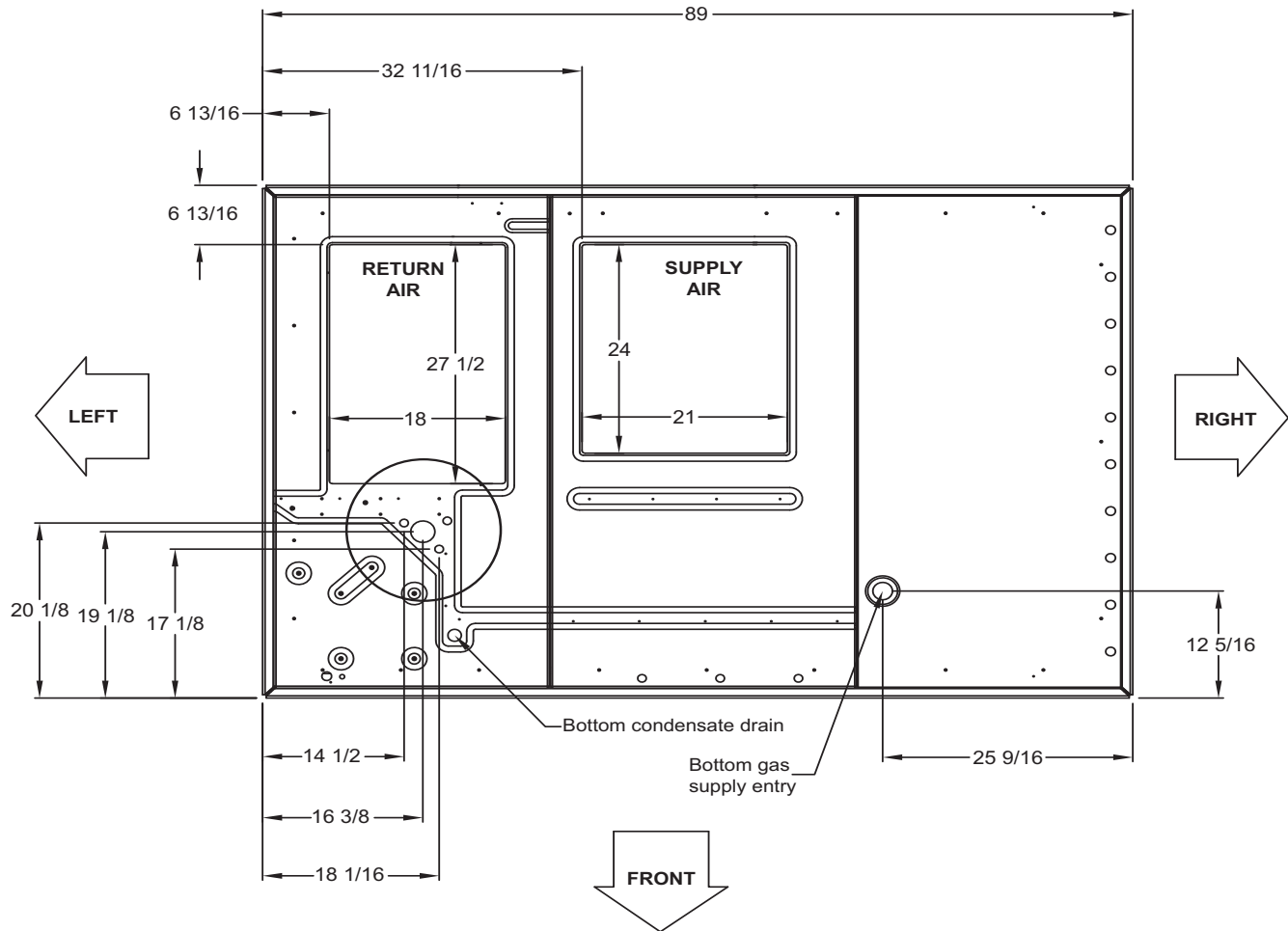

TOP VIEW

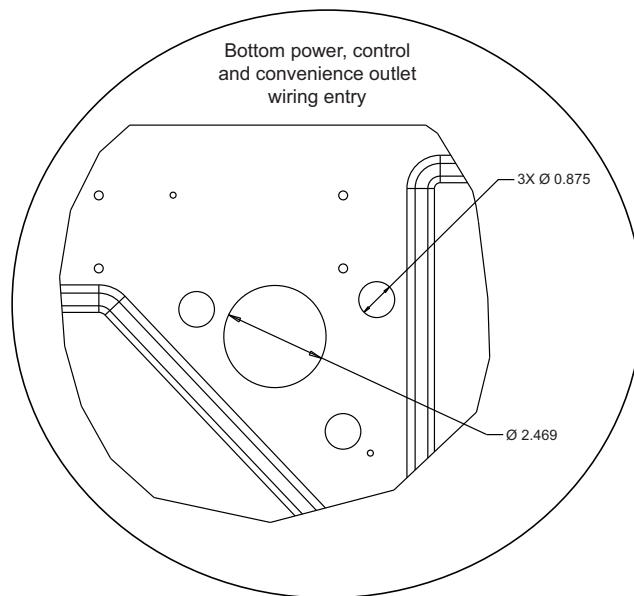

ZF078-150 Unit Electrical Entry

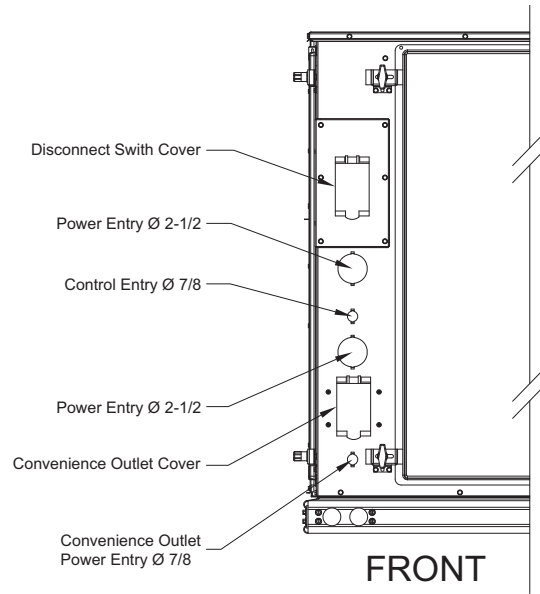

ZF078-120 Unit Side Duct Openings

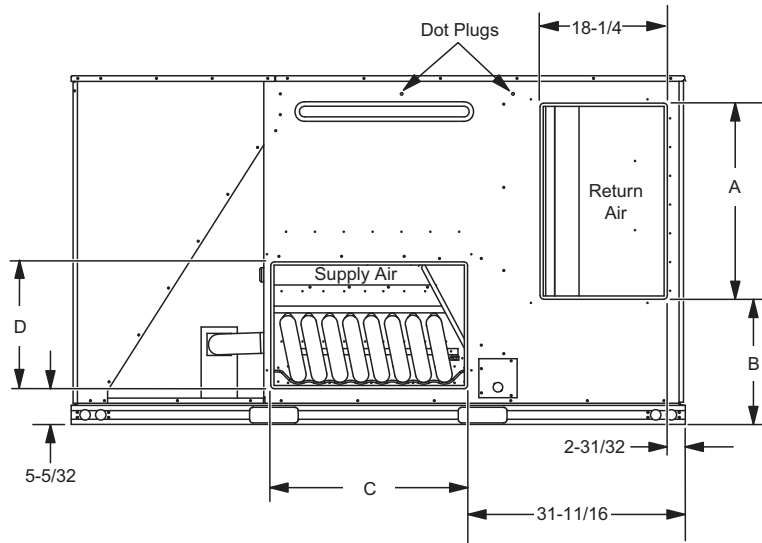

ZF150 Unit Side Duct Openings

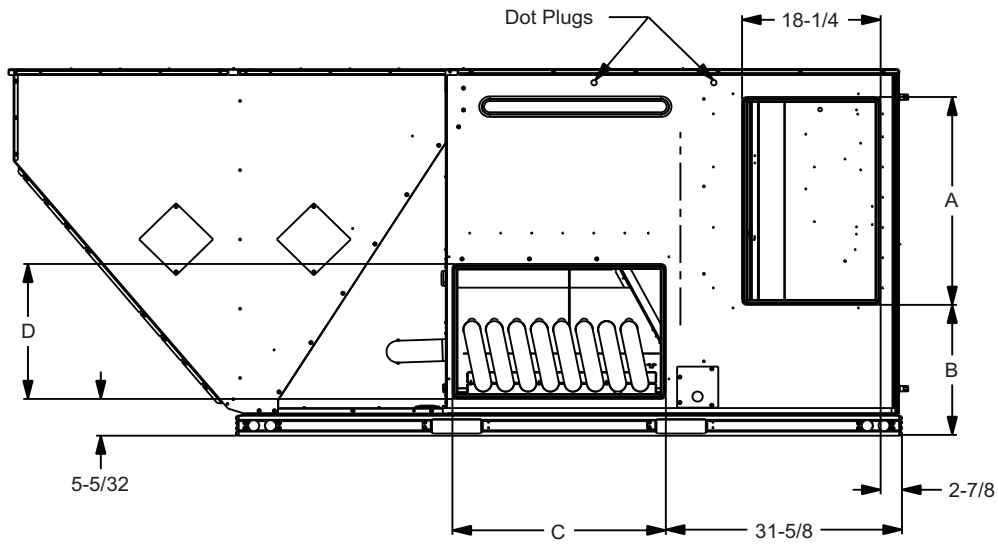

ZF Side Duct Dimensions

Unit Model Number	Dimension (in.)			
	A	B	C	D
078	27 3/4	12 1/16	27 1/2	16
090	27 3/4	12 1/16	27 1/2	16
102	28 1/4	18 1/16	28 1/4	18 1/4
120	28 1/4	18 1/16	28 1/4	18 1/4
150	28 1/4	18 1/16	28 1/4	18 1/4

ZF078-150 Unit Left Duct Opening

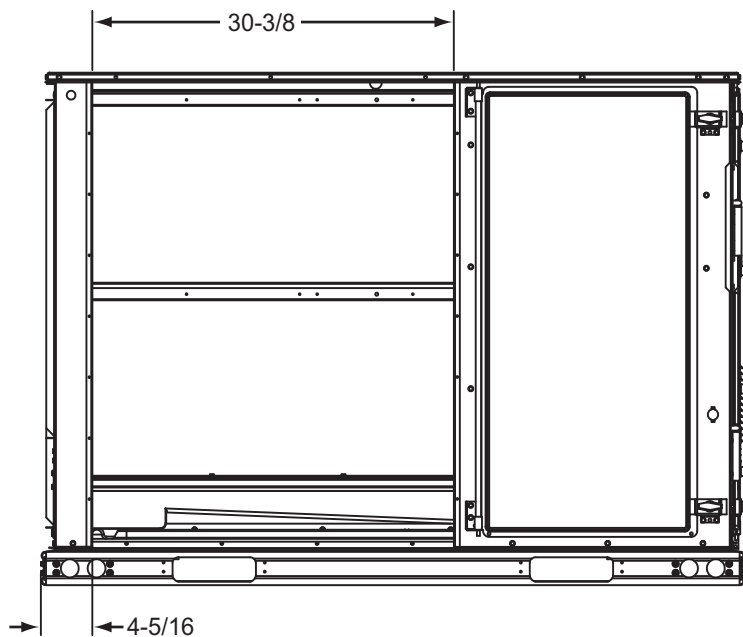

ZF078-150 Unit Accessory Dimensions

ZF078-150 Roof Curb

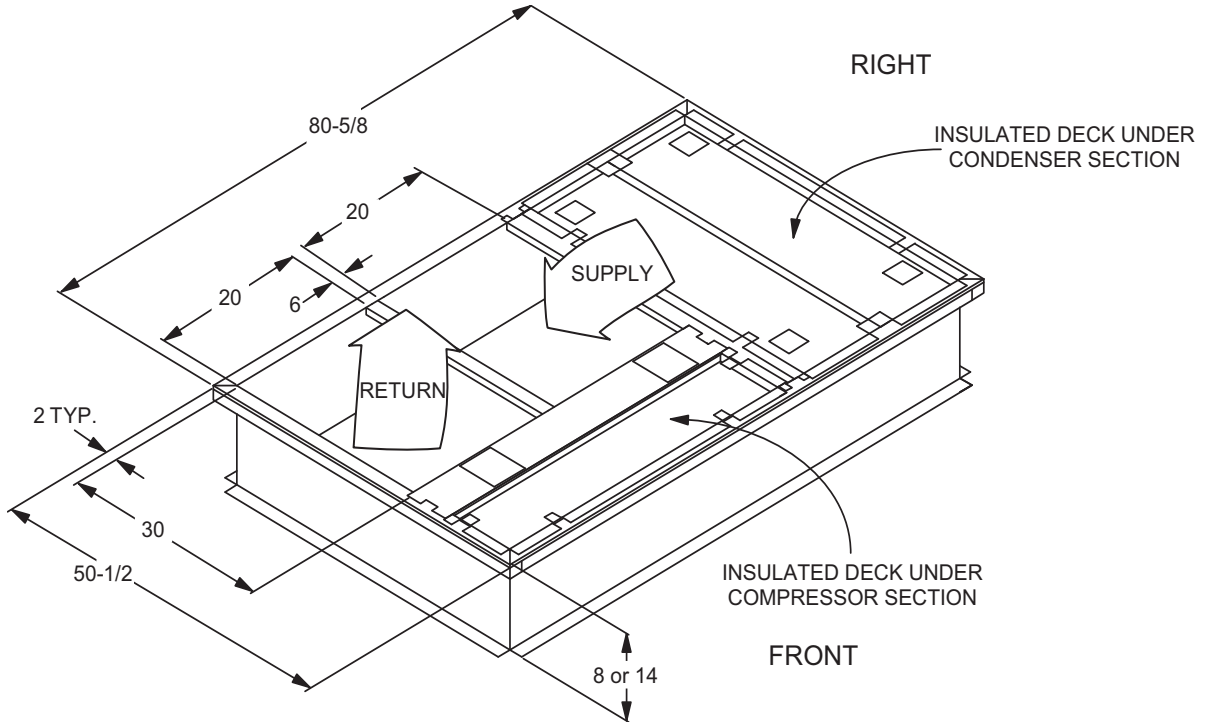

ZF078-150 Transition Roof Curb

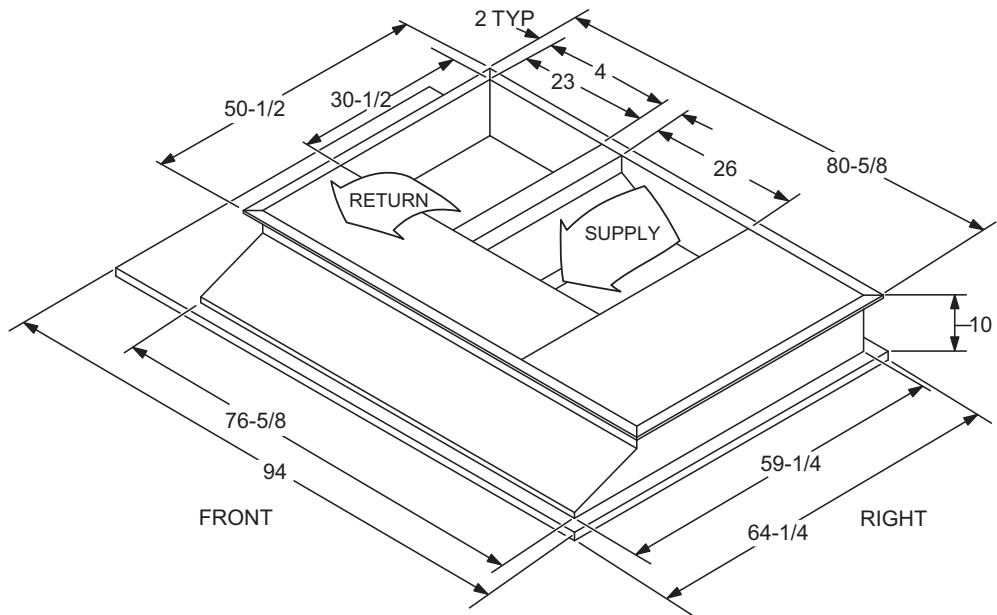

ZF078-150 Economizer Assembly

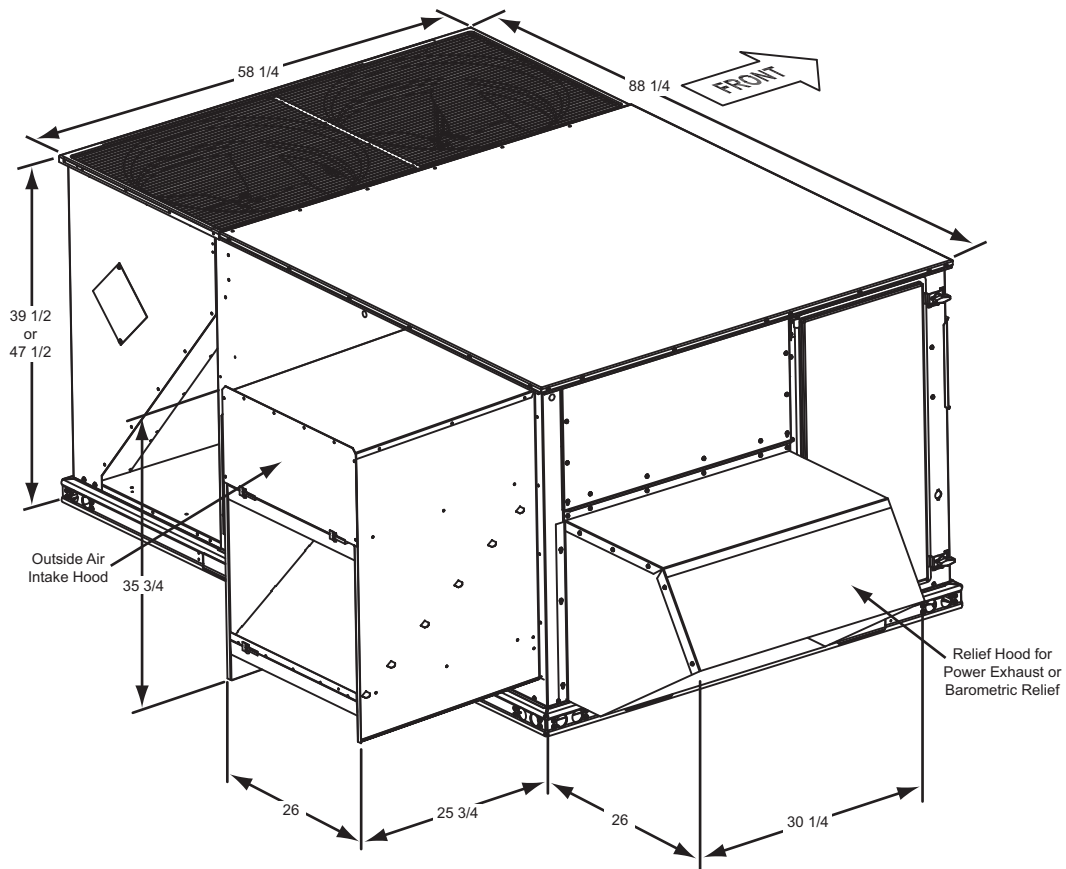

Economizer Options

Economizer Usage

Application	Cabinet Height	Description	Model
Bottom Return	All	Downflow economizer with barometric relief	2EE04705924
Side Return	All	Horizontal economizer without barometric relief	2EE04706024 ¹
ERV or End Return	42"	Slab Economizer, 42" tall cabinet	2EE04705824 ²
	50"	Slab Economizer, 50" tall cabinet	2EE04705724 ²

1. Barometric relief must be ordered separately and installed in duct work.
2. Barometric relief or fresh air hood not included. Must be ordered separately.

Factory Installed Downflow Economizer

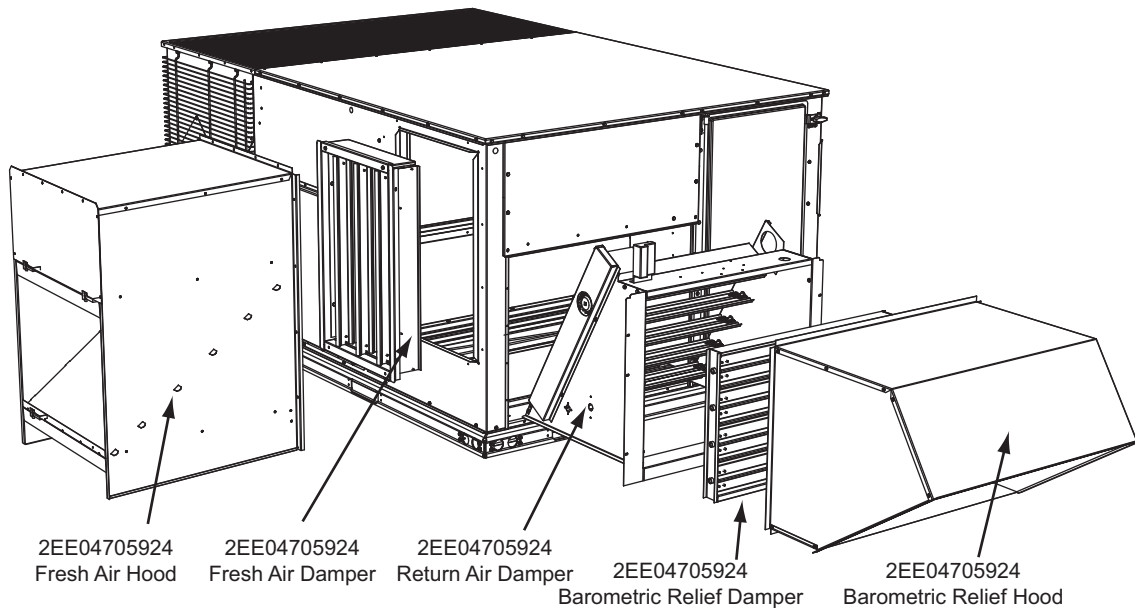

Field Installed Downflow Economizer W/Power Exhaust

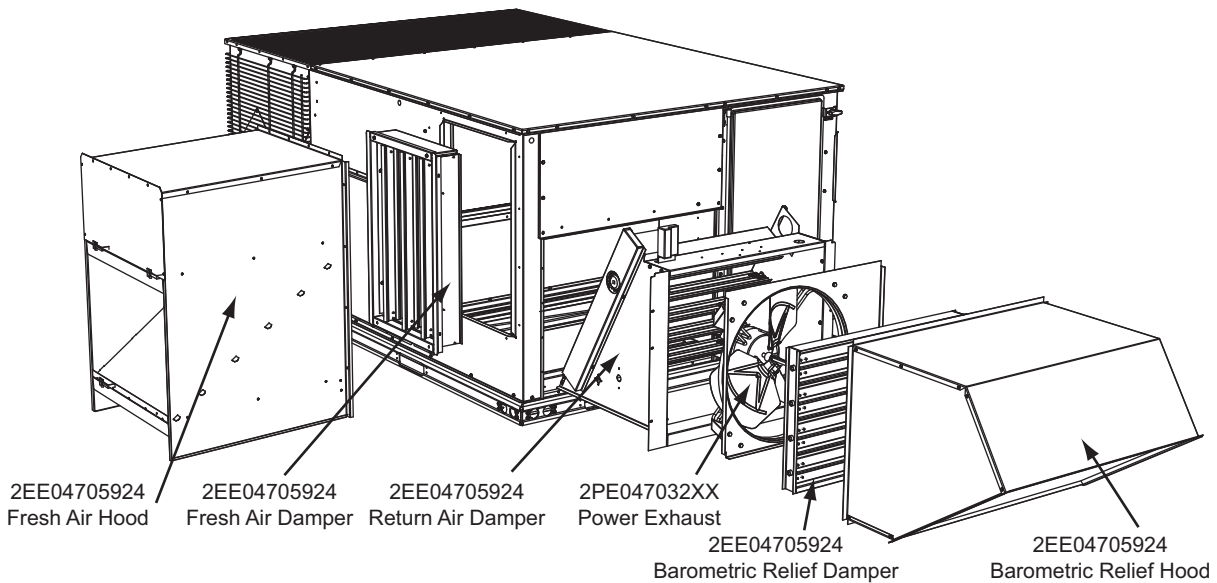

Field Installed Horizontal Economizer W/Power Exhaust

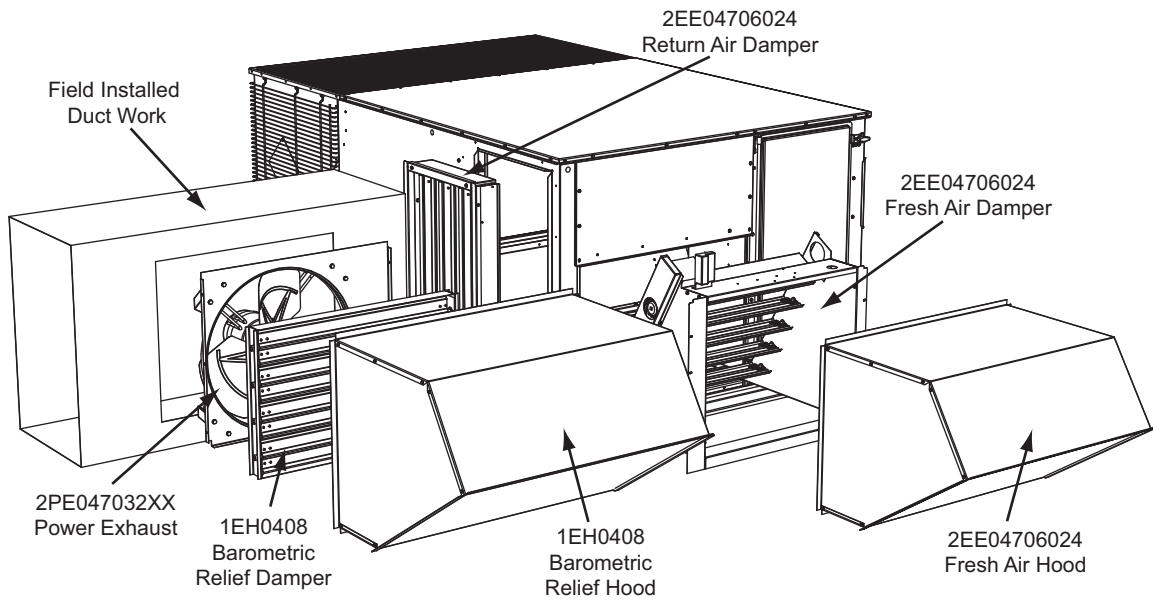

Slab Economizer Downflow W/Power Exhaust

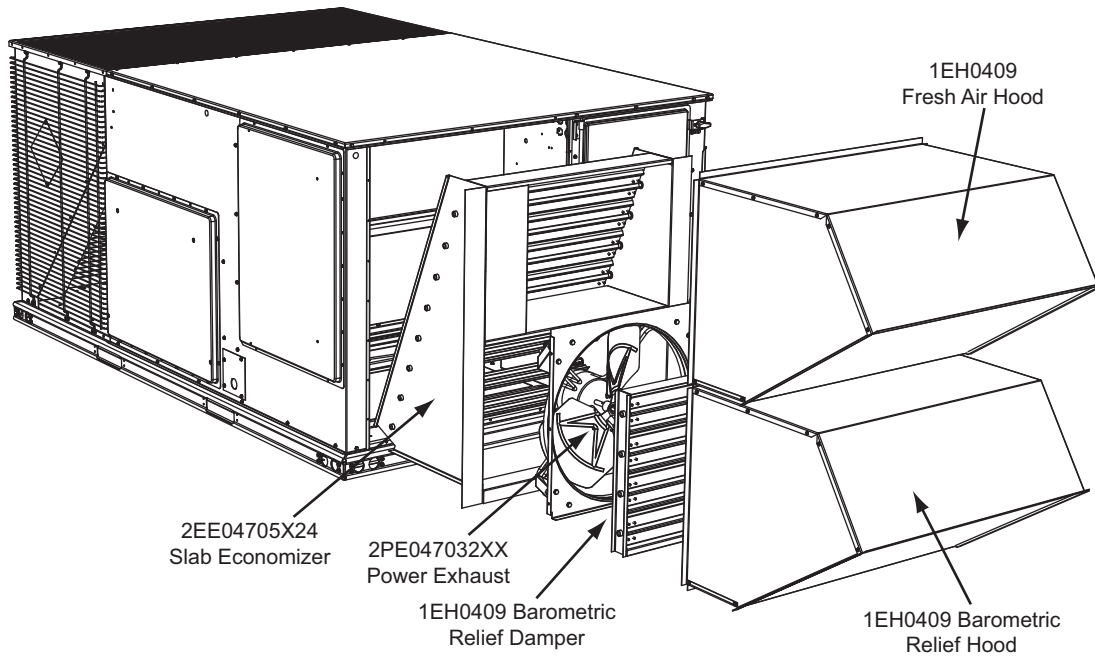

Slab Economizer End Return W/Power Exhaust

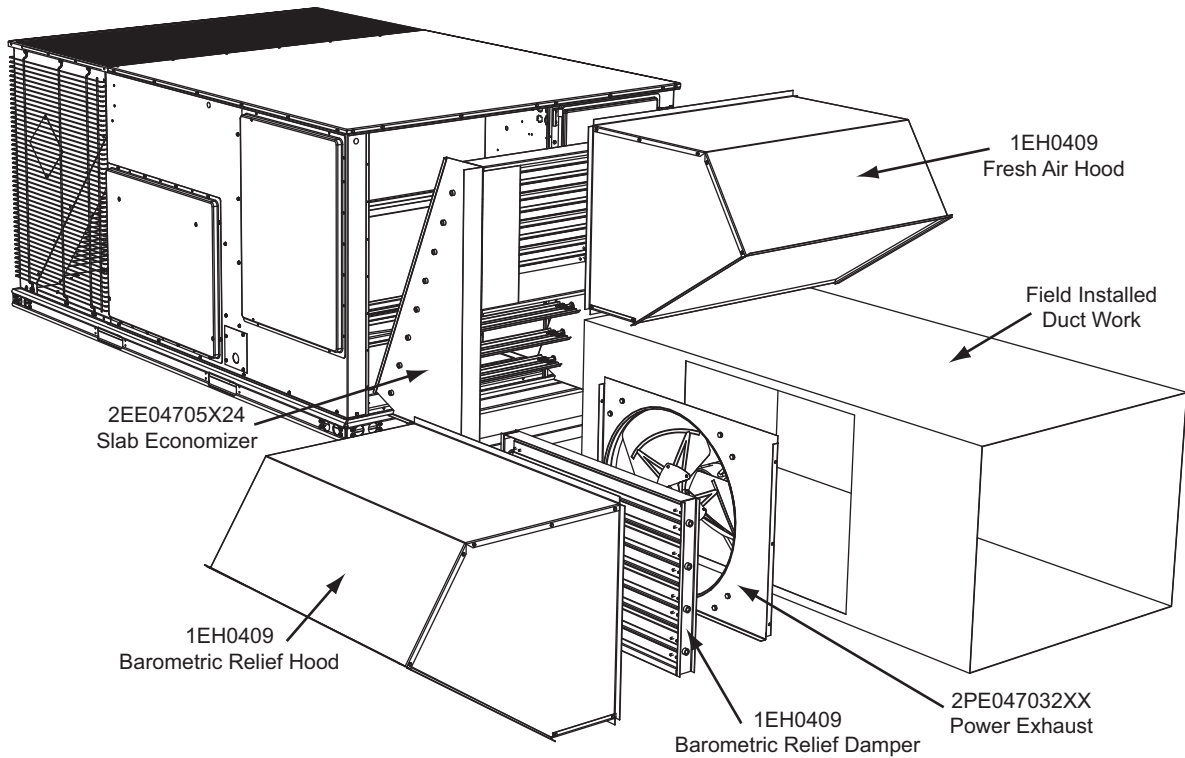

Subject to change without notice. Printed in U.S.A.
Copyright © 2011 by Johnson Controls, Inc. All rights reserved.

528194-YTG-F-1210
Supersedes: 528194-YTG-E-0810

Johnson Controls Unitary Products
5005 York Drive
Norman, OK 73069